

AVENTICS Series PRA Profile cylinders (ISO 15552)

The AVENTICS Series PRA (ISO 15552) cylinders have a compact design profile with integrated sensor slots. The Series PRA (ISO 15552) cylinders can be used for all industries. This includes general automation technology, machine and systems construction, as well as specific industry applications.



Technical data

| | |
|----------------------------------------|---------------------------------|
| Industry | Industrial |
| Standards | ISO 15552 |
| Piston Ø | 40 mm |
| Stroke | 50 mm |
| Ports | G 1/4 |
| Functional principle | Double-acting |
| Cushioning | Pneumatic adjustable cushioning |
| Magnetic piston | Piston with magnet |
| Environmental requirements | Industry standard |
| Piston rod thread - type | External thread |
| Piston rod thread | M12x1,25 |
| Piston rod | non-rotating |
| Scraper | Standard Industry Scraper |
| Pressure for determining piston forces | 6,3 bar |
| Retracting piston force | 660 N |
| Extracting piston force | 790 N |
| Min. ambient temperature | -20 °C |
| Max. ambient temperature | 80 °C |
| Min. working pressure | 1.5 bar |

Profile cylinder ISO 15552, PRA series

series PRA

R481601981

2024-04-12

| | |
|------------------------------------|---------------------|
| Max. working pressure | 10 bar |
| Cushioning length | 19 mm |
| Cushioning energy | 9 J |
| Max. torque for torsion protection | 1.5 Nm |
| Rotation angle tolerance (±) | 1.6 ° |
| Weight 0 mm stroke | 0.65 kg |
| Weight +10 mm stroke | 0.032 kg |
| Stroke max. | 1500 mm |
| Medium | Compressed air |
| Min. medium temperature | -20 °C |
| Max. medium temperature | 80 °C |
| Max. particle size | 50 µm |
| Min. oil content of compressed air | 0 mg/m ³ |
| Max. oil content of compressed air | 5 mg/m ³ |

Material

| | |
|-----------------------|----------------------|
| Piston rod | Stainless Steel |
| Scraper material | Polyurethane |
| Seal material | Polyurethane |
| Material, front cover | Die-cast aluminum |
| Cylinder tube | Aluminum |
| End cover | Die-cast aluminum |
| Nut for piston rod | Steel, chrome-plated |
| Part No. | R481601981 |

Technical information

ATEX-certified cylinders with identification II 2G Ex h IIC T4 Gb / II 2D Ex h IIIC T135°C Db_X can be generated in the Internet configurator.

The operating temperature range for ATEX-certified cylinders is -20°C ... 60°C.

The pressure dew point must be at least 15 °C less than ambient and medium temperature and may not exceed 3 °C.

The oil content of compressed air must remain constant during the life cycle.

Use only the approved oils from AVENTICS. Further information can be found in the "Technical information" document (available in <https://www.emerson.com/en-us/support>).

Profile cylinder ISO 15552, PRA series

R481601981

series PRA

2024-04-12

Dimensions

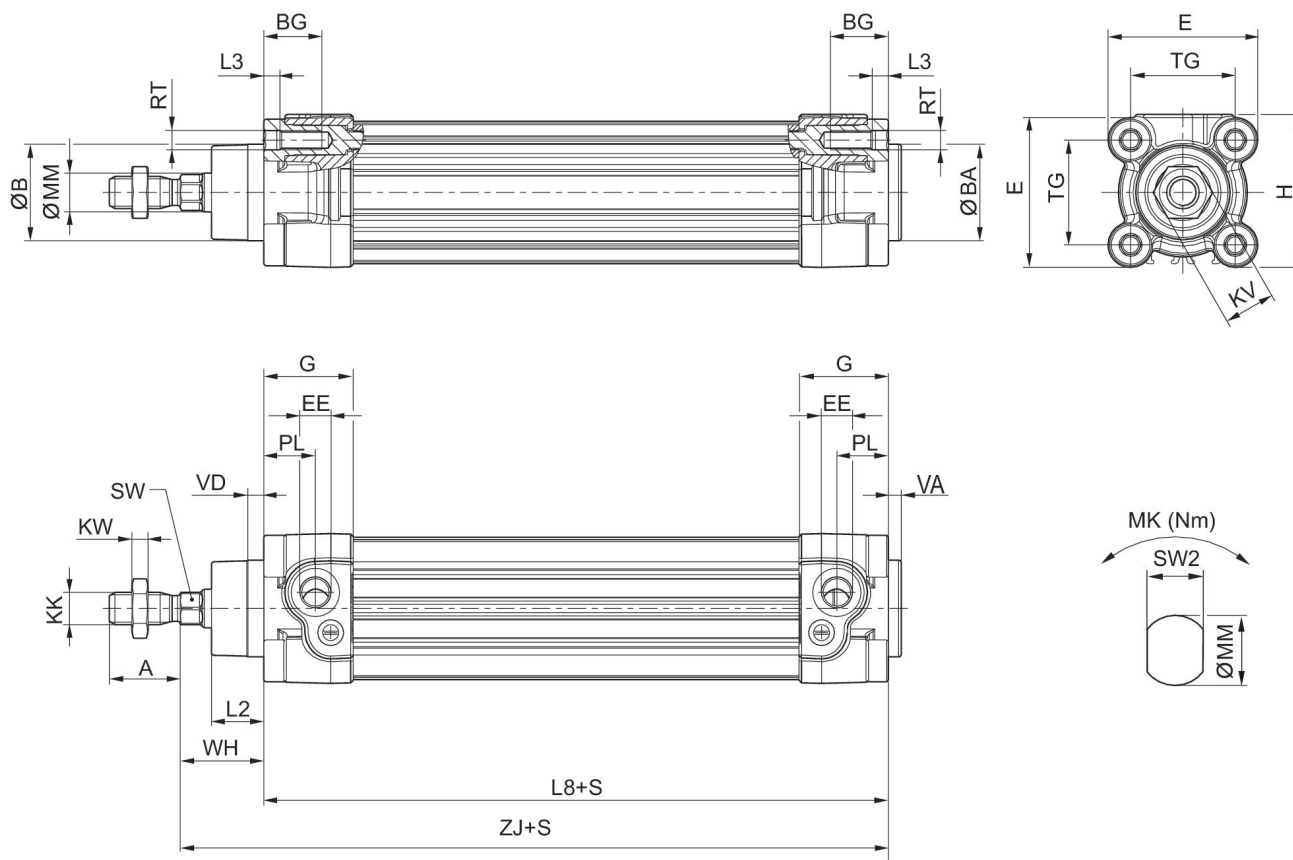

S = stroke

| Piston Ø | A -2 | ØB d11 | ØBA d11 | BG min. | E | EE | G | H | KK |
|----------|------|--------|---------|---------|------|-------|-------|------|----------|
| 32 | 22 | 30 | 30 | 16 | 46.5 | G 1/8 | 27.75 | 47.5 | M10x1,25 |
| 40 | 24 | 35 | 35 | 16 | 53 | G 1/4 | 33.25 | 53 | M12x1,25 |
| 50 | 32 | 40 | 40 | 16 | 65 | G 1/4 | 31 | 65 | M16x1,5 |
| 63 | 32 | 45 | 45 | 16 | 75 | G 3/8 | 38.25 | 75 | M16x1,5 |

| Piston Ø | KV | KW | ØMM f8 | PL | L2 | L3 ±0,5 | L8 | RT | SW |
|----------|----|----|--------|----|-------|---------|---------|----|-----|
| 32 | 16 | 5 | 12 | 16 | 16.25 | 4.5 | 94±0,4 | M6 | 10 |
| 40 | 18 | 6 | 16 | 20 | 18.25 | 4.5 | 105±0,7 | M6 | 13 |
| 50 | 24 | 8 | 20 | 19 | 25 | 4.5 | 106±0,7 | M8 | 16* |
| 63 | 24 | 8 | 20 | 24 | 25 | 4.5 | 121±0,8 | M8 | 16* |

| Piston Ø | TG | VA -1 | VD | WH | ZJ | MK | SW2 |
|----------|----------|-------|----|--------|-----|------|-----|
| 32 | 32,5±0,5 | 4 | 5 | 26±1,4 | 120 | 0,75 | 10 |
| 40 | 38±0,5 | 4 | 5 | 30±1,4 | 135 | 1,5 | 13 |
| 50 | 46,5±0,6 | 4 | 5 | 37±1,4 | 143 | 2 | 16 |
| 63 | 56,5±0,7 | 4 | 5 | 37±1,8 | 158 | 2 | 16 |

* not according to ISO 15552

Cushioning diagram



v_1 = Piston velocity [m/s] m = Cushionable mass [kg]

Profile cylinder ISO 1552, PRA series

series PRA

R481601981

2024-04-12

