

Bellow actuator with cover, series BCP, single, air connection in the mounting hole, Heat resistant

R412010209

Series BCE

Heat-resistant version

BCE
2024-09-13

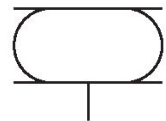

Technical data

Industry	Industrial
Bellows	single
Type	Bellow actuator with cover
Functional principle	Single-acting, retracted without pressure
Compressed air connection	G 3/4
Cover diameter	141 mm
Max. permissible angle of tilt	20 °
Max. effective stroke	107 mm
Min. radial installation space	250 mm
Min. installation height	54 mm
Max. installation height	158 mm
Min. force	7000 N
Max. force	14000 N
Min. working pressure	0 bar
Max. working pressure	8 bar
Min. ambient temperature	-20 °C
Max. ambient temperature	130 °C
Medium	Compressed air
Reduced service life at a temperature greater than	115 °C

Bellow actuator with cover, series BCP, single, air connection in the mounting hole, Heat resistant

BCE
2024-09-13

Pressure for determining forces	6 bar
R412010209	
Weight	1.9 kg

Material

Material bellow	Epichlorohydrin rubber
Material front cover	Steel, chrome-plated
Surface cover	galvanized
Part No.	R412010209

Technical information

Compliance with the minimum height H min. as well as the maximum height H max. must be ensured with end stops.

Use at operating height $\geq H_{max}$: only permitted upon approval by AVENTICS

Further information on vibration isolation can be found in the "Technical information" document (available in the MediaCentre).

Bellow actuator with cover, series BCP, single, air connection in the mounting hole, Heat

resistant
Dimensions
R412010209

BCE
2024-09-13

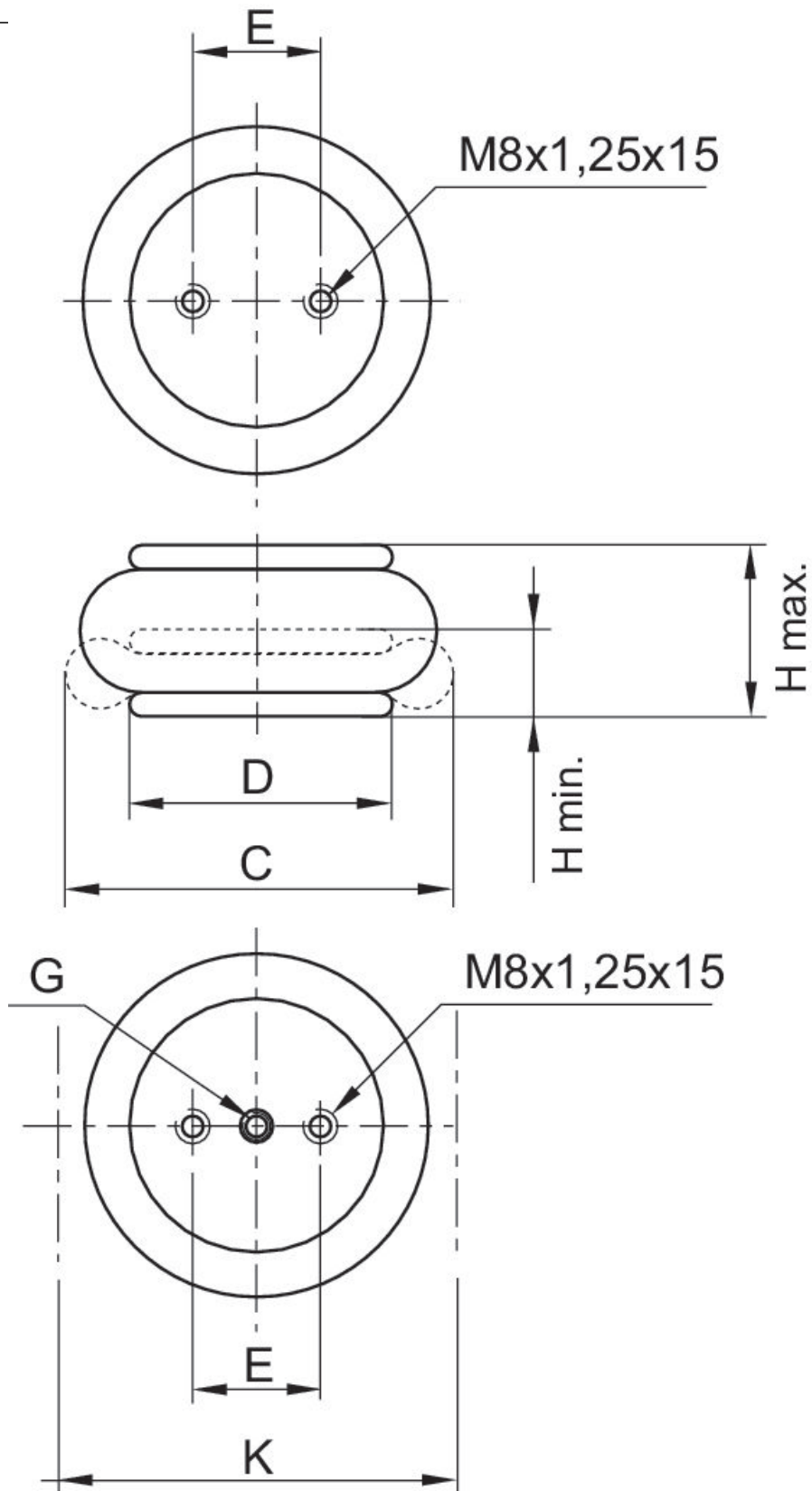

Bellow actuator with cover, series BCP, single, air connection in the mounting hole, Heat resistant

BCE
2024-09-13

R412010209

Part No.	Compressed air connection G	H min. mm	H max. mm	C mm	D mm	E ±0,5 [mm]	K mm	Min. return force N
R412010207	G 1/4	54	85	150	108	44.5	165	250
R412004943	G 1/4	51	105	165	108	44.5	180	200
R412010208	G 1/4	54	130	210	114	44.5	225	45
R412007812	G 3/4	50	125	215	141	44.5	230	200
R412010209	G 3/4	54	158	235	141	70	250	200

Comment

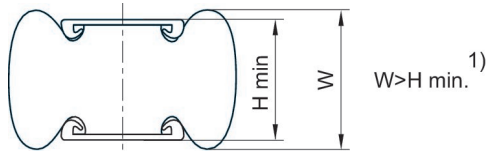

1) Once the minimum height H min. is reached, the bead height W can fall below the lower limit. If, for these products, level mounting surfaces greater than the cover diameter are selected, the return force and force output at the start of stroke increase. In the process, the rubber bellow is also compressed by the mounting surfaces. These products require more space upward, which can, in rare cases, present a hindrance. In any case, the specifications of the data sheets apply when using mounting surfaces in the size of the bellows actuator cover.
1 kN = 1000 N

Force-displacement diagram R412010209

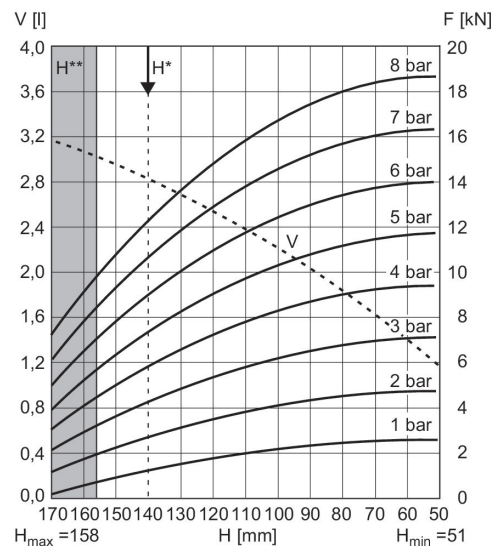

V = volume H = height H* = recommended operating height for vibration isolation H** = use permitted only upon approval by AVENTICS
1 kN = 1000 N