

Bellow actuator with cover, series BCP, single, air connection between 3 mounting holes, Heat resistant

BCE
2024-09-13

R412010211

Series BCE

Heat-resistant version

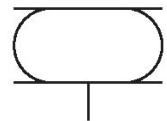

Technical data

Industry	Industrial
Bellows	single
Type	Bellow actuator with cover
Functional principle	Single-acting, retracted without pressure
Compressed air connection	G 3/4
Cover diameter	228 mm
Max. permissible angle of tilt	20 °
Max. effective stroke	89 mm
Min. radial installation space	340 mm
Min. installation height	54 mm
Max. installation height	140 mm
Min. force	19400 N
Max. force	33300 N
Min. working pressure	0 bar
Max. working pressure	8 bar
Min. ambient temperature	-20 °C
Max. ambient temperature	130 °C
Medium	Compressed air
Reduced service life at a temperature greater than	115 °C

Bellow actuator with cover, series BCP, single, air connection between 3 mounting holes, Heat resistant

BCE
2024-09-13

Pressure for determining forces	6 bar
Weight	3.9 kg

Material

Material bellow	Epichlorohydrin rubber
Material front cover	Steel, chrome-plated
Surface cover	galvanized
Part No.	R412010211

Technical information

Compliance with the minimum height H min. as well as the maximum height H max. must be ensured with end stops.

Use at operating height $\geq H_{max}$: only permitted upon approval by AVENTICS

Further information on vibration isolation can be found in the "Technical information" document (available in the MediaCentre).

The pressure dew point must be at least 15 °C less than ambient and medium temperature and may not exceed 3 °C.

The oil content of compressed air must remain constant during the life cycle.

Use only the approved oils from AVENTICS. Further information can be found in the "Technical information" document (available in <https://www.emerson.com/en-us/support>).

Bellow actuator with cover, series BCP, single, air connection between 3 mounting holes, Heat resistant

Dimensions
R412010211

BCE
2024-09-13

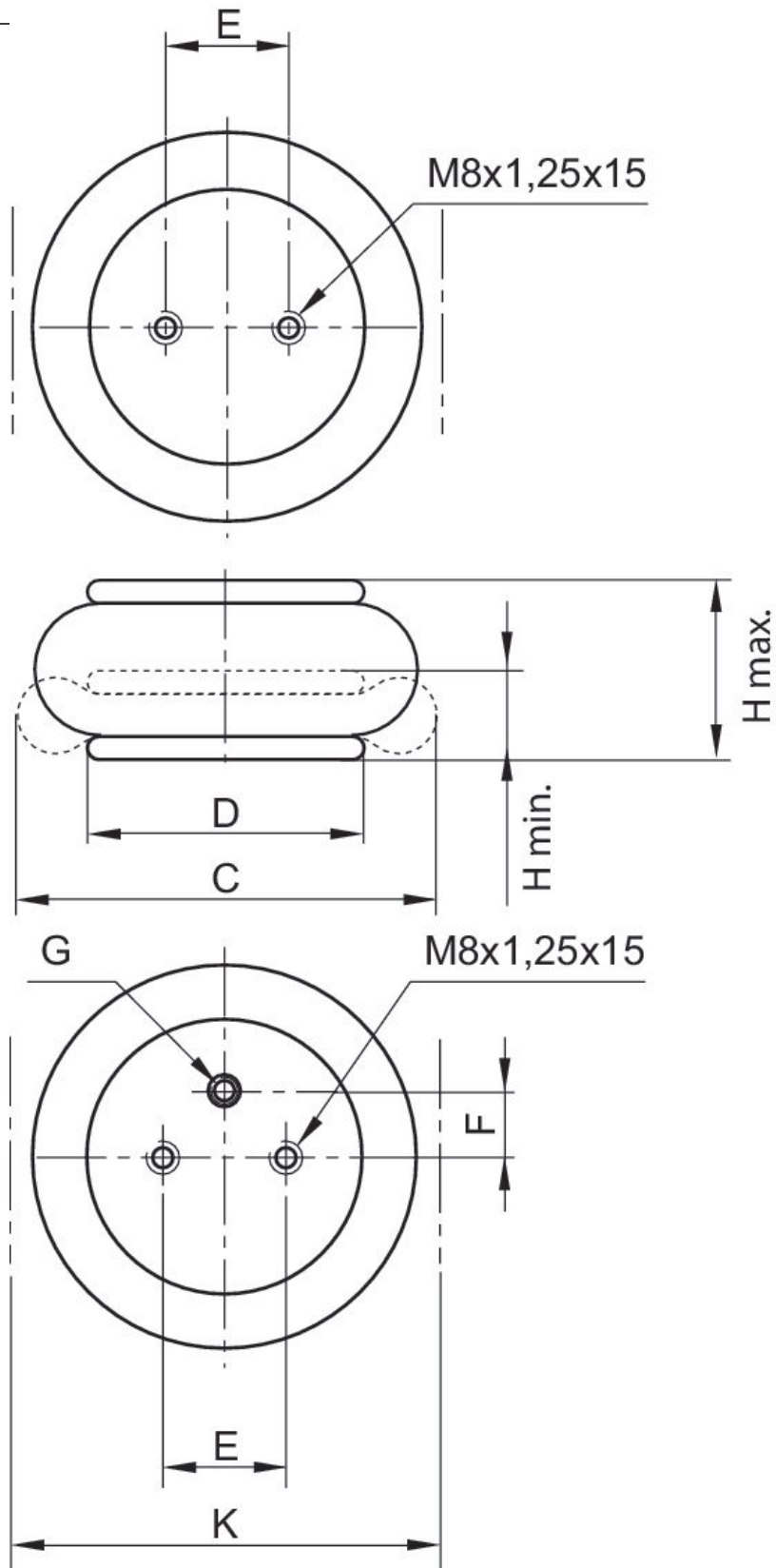

Bellow actuator with cover, series BCP, single, air connection between 3 mounting holes, Heat resistant

BCE
2024-09-13

R412010211

Part No.	Compressed air connection G	H min. mm	H max. mm	C mm	D mm	E ±0,5 [mm]	F ±0,5 [mm]	K mm	Min. return force N
R412010210	G 3/4	54	125	250	161	89	38.1	265	200
R412010211	G 3/4	54	140	325	228	157.5	73	340	300

Comment

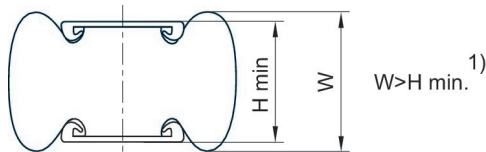

1) Once the minimum height H min. is reached, the bead height W can fall below the lower limit. If, for these products, level mounting surfaces greater than the cover diameter are selected, the return force and force output at the start of stroke increase. In the process, the rubber bellow is also compressed by the mounting surfaces. These products require more space upward, which can, in rare cases, present a hindrance. In any case, the specifications of the data sheets apply when using mounting surfaces in the size of the bellows actuator cover.

1 kN = 1000 N

Force-displacement diagram R412010211

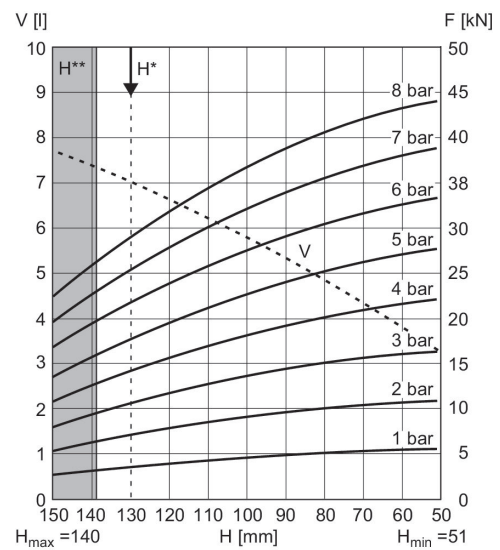

V = volume H = height H* = recommended operating height for vibration isolation H** = use permitted only upon approval by AVENTICS
1 kN = 1000 N