

# Bellow actuator with cover, series BCP, single, 4 mounting holes

R432039300

BCP  
2024-09-12

## Series BCP - inch

Bellows actuators with flanged connectors  
Force max. 12000 Lbf  
Stroke max. 11,22 inch

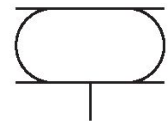

## Technical data

Industry	Industrial
Bellows	single
Type	Bellow actuator with cover
Functional principle	Single-acting, retracted without pressure
Compressed air connection	3/4 NPT
Cover diameter	287 mm
Max. permissible angle of tilt	15 °
Max. effective stroke	736.6 mm
Min. radial installation space	420 mm
Min. installation height	51 mm
Max. installation height	160 mm
Min. force	35200 N
Max. force	52200 N
Min. working pressure	0 bar
Max. working pressure	8 bar
Min. ambient temperature	-40 °C
Max. ambient temperature	70 °C
Medium	Compressed air
Reduced service life at a temperature greater than	50 °C

# Bellow actuator with cover, series BCP, single, 4 mounting holes

BCP  
2024-09-12

R432039300

Pressure for determining forces 6 bar

---

Weight 6.1 kg

## Material

Material bellow Natural rubber

Material front cover Steel, chrome-plated

Surface cover galvanized

Part No. R432039300

## Technical information

Compliance with the minimum height H min. as well as the maximum height H max. must be ensured with end stops.

Use at operating height  $\geq H_{max}$ : only permitted upon approval by AVENTICS

Further information on vibration isolation can be found in the "Technical information" document (available in the MediaCentre).

Reduced service life at a temperature greater than

The pressure dew point must be at least 15 °C less than ambient and medium temperature and may not exceed 3 °C.

The oil content of compressed air must remain constant during the life cycle.

Use only the approved oils from AVENTICS. Further information can be found in the "Technical information" document (available in <https://www.emerson.com/en-us/support>).

# Bellow actuator with cover, series BCP, single, 4 mounting holes

BCP  
2024-09-12

R432039300  
Dimensions

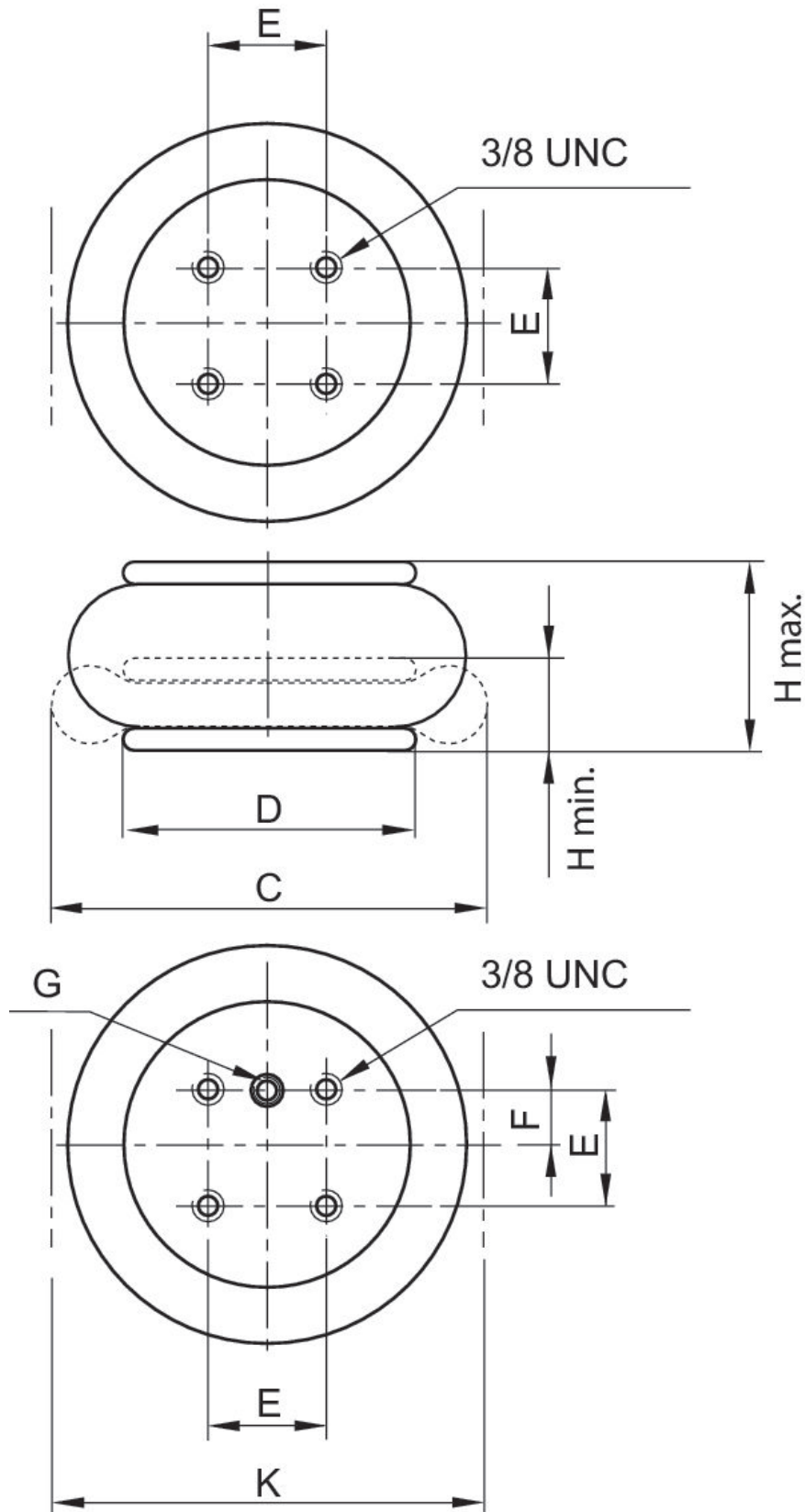

# Bellow actuator with cover, series BCP, single, 4 mounting holes

BCP  
2024-09-12

R432039300

Part No.	Compressed air connection	H min. in	H max. in	C in	D in	E ±0,5 in	F ±0,5 in	K in	Min. return force lbf
R432039297	3/4 NPT	2.0	6.10	15.16	11.30	6.25	3.13	15.75	67
R432039300	3/4 NPT	2.0	6.30	15.94	11.30	6.25	3.13	16.54	67

## Comment

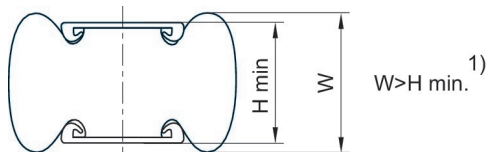

1) Once the minimum height H min. is reached, the bead height W can fall below the lower limit. If, for these products, level mounting surfaces greater than the cover diameter are selected, the return force and force output at the start of stroke increase. In the process, the rubber bellow is also compressed by the mounting surfaces. These products require more space upward, which can, in rare cases, present a hindrance. In any case, the specifications of the data sheets apply when using mounting surfaces in the size of the bellows actuator cover.

1 kN = 1000 N

## Force-displacement diagram R432039300

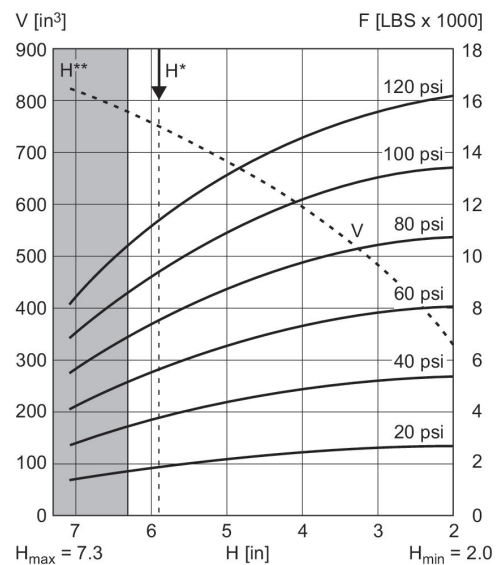

V = volume H = height H\* = recommended operating height for vibration isolation H\*\* = use permitted only upon approval by AVENTICS  
1 kN = 1000 N