

# 3/2-directional valve, Series DP30-LT

R414012065

- The AVENTICS Series DP30-LT consists of a range of pilot control functions with direct electrical operation with a robust and durable aluminum housing. DP30-LT is designed for working in extreme ambient temperature conditions – 40°C to +70°C and extended voltage tolerance -30% to +25%. Series DP30-LT is ideal for piloting applications in harsh environments and meets international standards for Railway applications.

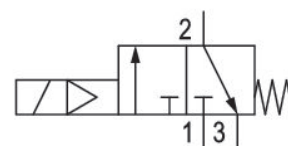

## Technical data

Industry	Rail
Activation	Electrically
Nominal flow Qn	60 l/min
Switching principle	3/2
Function	NC
Compressed air connection output	Subbase CNOMO 06 05 80
Compressed air connection input	Subbase CNOMO 06 05 80
Compressed air connection, exhaust	M5
Working pressure min.	2.5 bar
Working pressure max	10 bar
Orifice size	1.3 mm
Duty cycle	100 %
Operational voltage	24 V DC
Voltage tolerance DC	-30% / +25%
Manual override	without

Electrical connection type	Plug
Electrical connection size	EN 175301-803, form A
Electrical connection number of poles	3-pin
Actuating control	Single Solenoid
Sealing principle	soft seal
Certificates	CE declaration of conformity RoHS UR (Underwriters Laboratories)
Pilot valve width	30 mm
Valve type	Poppet valve
Return	With spring return
Min. ambient temperature	-40 °C
Max. ambient temperature	70 °C
Min. medium temperature	-40 °C
Max. medium temperature	70 °C
Medium	Compressed air
Max. particle size	50 µm
Oil content of compressed air min.	0 mg/m <sup>3</sup>
Oil content of compressed air max.	1 mg/m <sup>3</sup>
Power consumption DC	5.5 W
Protection class with connection	IP65
Reverse polarity protection	Protected against polarity reversal
Weight	0.2 kg
<b>Material</b>	
Housing material	Aluminum
Material Coil	Polyamide fiber-glass reinforced
Screws material	Stainless Steel
Seal material	Hydrogenated nitrile butadiene rubber
Part No.	R414012065

## Technical information

The min. control pressure must be adhered to, since otherwise faulty switching and valve failure may result!

The pressure dew point must be at least 15 °C less than ambient and medium temperature and may not exceed 3 °C.

The oil content of compressed air must remain constant during the life cycle.

Use only the approved oils from AVENTICS. Further information can be found in the “Technical information” document (available in <https://www.emerson.com/en-us/support>).

The protection class is only ensured when the plug is mounted properly. For detailed information, see operating instructions.

## Dimensions

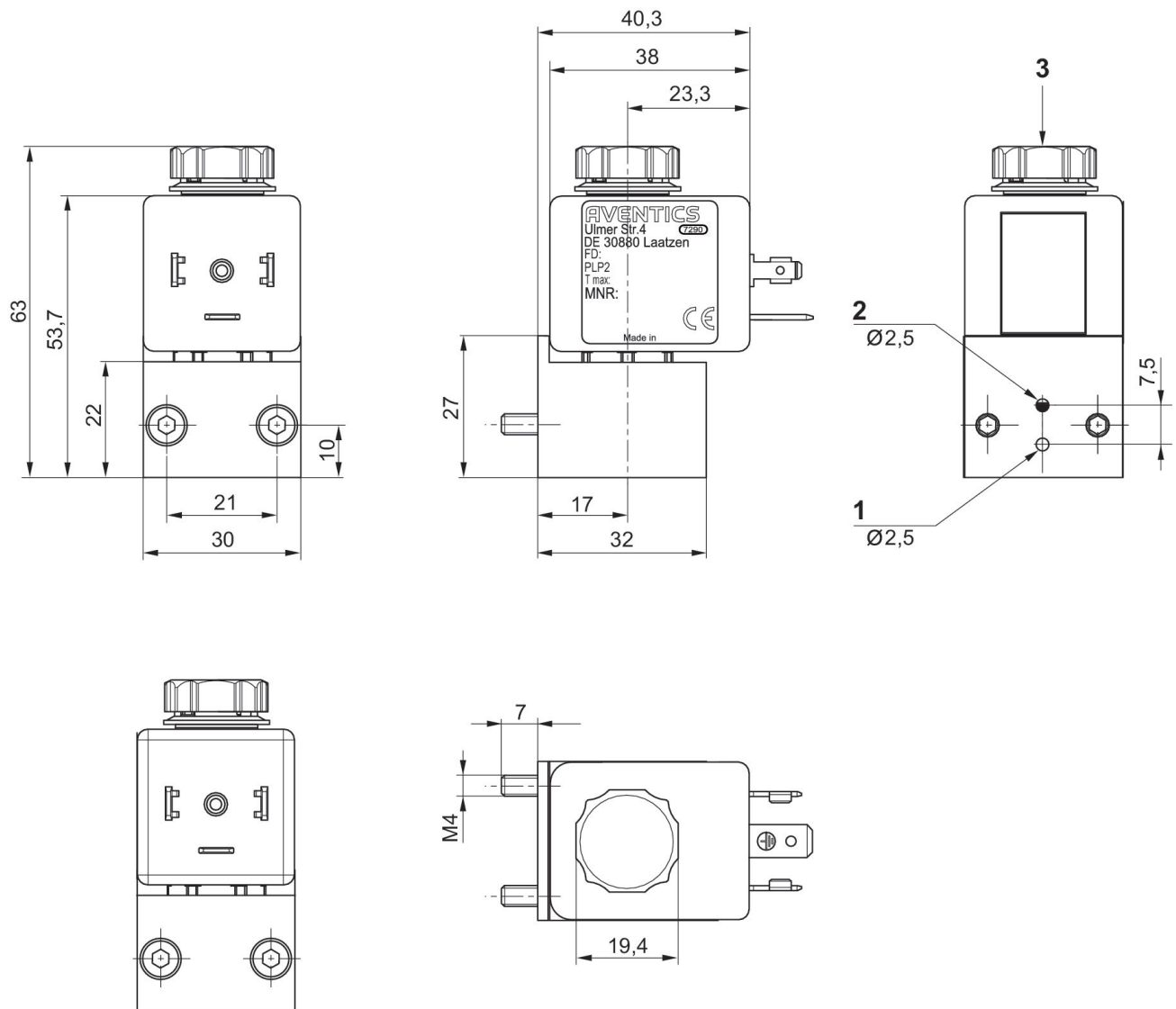

- 1) Port 1 (Input)
- 2) Port 2 (Output)
- 3) Port 3 (Exhaust) with silencer