

Rotary Compact Module, Series RCM-SH

2024-04-05

R412000369

The AVENTICS Series RCM with its rotary modules can perform all standardized rotary and swivel movements. These modules can be installed directly on mini slides and are equipped with mechanical grippers.

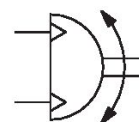

Technical data

Industry	Industrial
Diameter	12 mm
Compressed air connection	M5
Magnetic piston	with magnetic piston
Rotary compact module version	Double piston with rack
Easy2Combine	capable
Frame size	RCM-12
Theoretical torque at	6 bar
Min. swivel times	0.3 s
Air consumption per rotation	5.86 cm ³
Max. permissible axial bearing load	330 N
Radial shaft load	360 N
Max. permissible mass moment of inertia	10 kg cm ²
Theoretical torque	0.95 Nm
Repetitive precision	0.05 °
Cushioning	hydraulic
Cushioning	non-adjustable
Min. angle of rotation	0 °
Max. angle of rotation	90 °

R412000369

Min. working pressure	2 bar
Max. working pressure	8 bar
Min. ambient temperature	5 °C
Max. ambient temperature	60 °C
Min. medium temperature	5 °C
Max. medium temperature	60 °C
Medium	Compressed air
Min. oil content of compressed air	0 mg/m ³
Max. oil content of compressed air	1 mg/m ³
Max. particle size	5 µm
Weight	0.46 kg

Material

Housing material	Aluminum
Surface housing	anodized
Material front cover	Aluminum
Surface cover	black anodized
Material base	Aluminum
Surface base	black anodized
Seal material	Acrylonitrile butadiene rubber
Material axis	Steel, chrome-plated
Surface axis	hardened
Material rotary flange	Steel, chrome-plated
Surface rotary flange	hardened
Part No.	R412000369

Technical information

The pressure dew point must be at least 15 °C less than ambient and medium temperature and may not exceed 3 °C.

The oil content of compressed air must remain constant during the life cycle.

Use only the approved oils from AVENTICS. Further information can be found in the “Technical information” document (available in <https://www.emerson.com/en-us/support>).

Rotary Compact Module, Series RCM-SH

2024-04-05

R412000369

RCM-12/.../-25

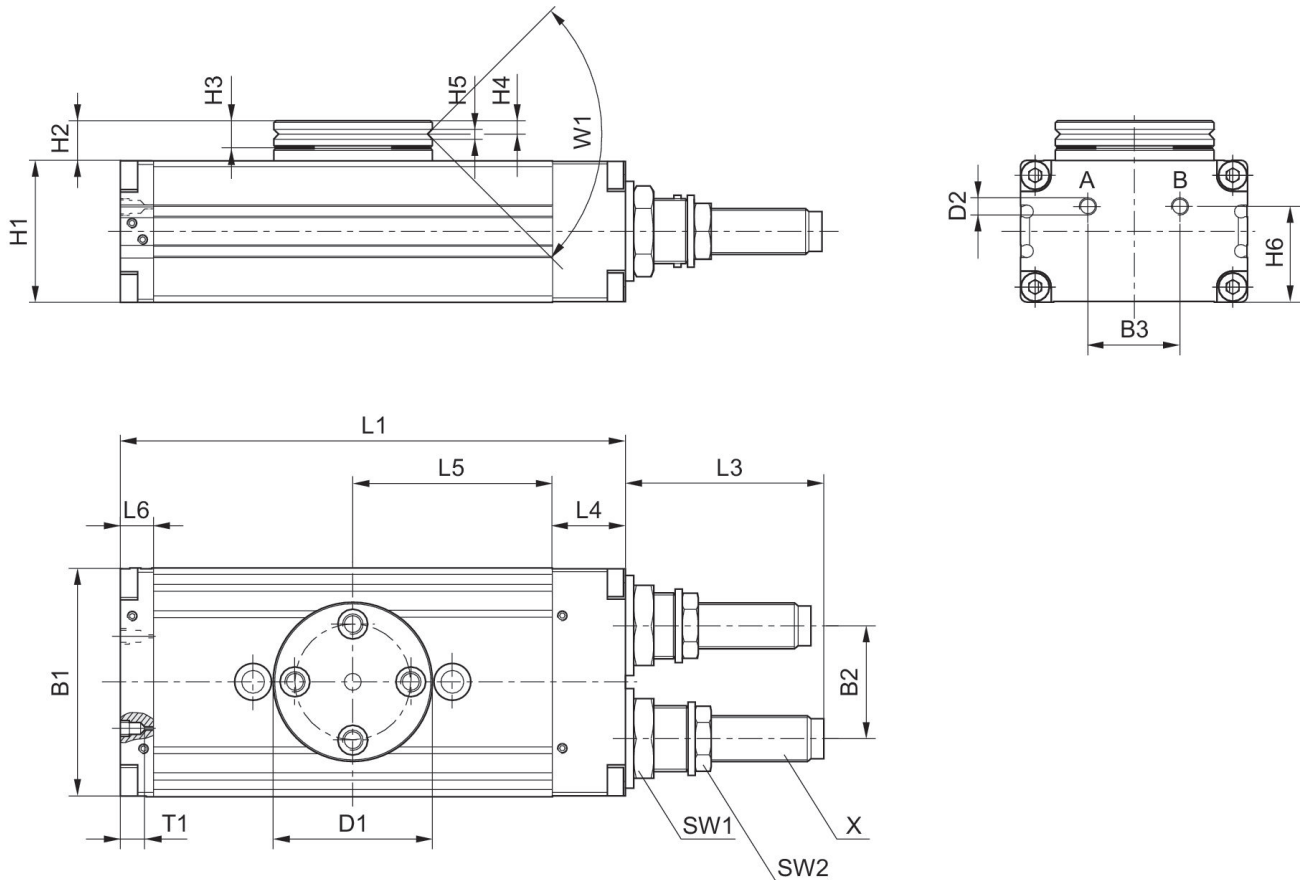

T1 = depth of thread

Part No.	B1	B2	B3	Ø D1	Ø D2	H1	H2	H3	H4
R412000369	43	18	18	35	M5	24	10.5	6	2.9
R412000370	43	18	18	35	M5	24	10.5	6	2.9

Part No.	H5	H6	L1	L3	L4	L5	L6	SW1	SW2
R412000369	2.5	18	103	33.5	14	40	9	15	11
R412000370	2.5	18	103	33.5	14	40	9	15	11

Part No.	T1	W1	X
R412000369	4	90°	M8x1
R412000370	4	90°	M8x1

Mounting and assembly RCM-12

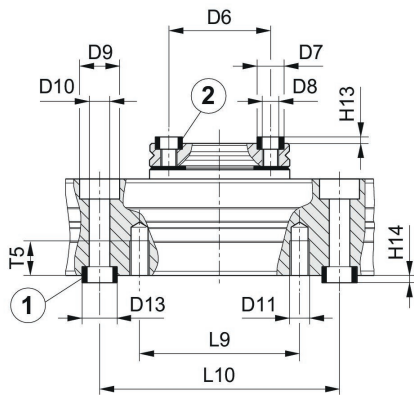

1) centering sleeve, included in the scope of delivery 2) centering sleeve

Maximum permissible axial force F_x [N] as a function of u [mm] RCM 12

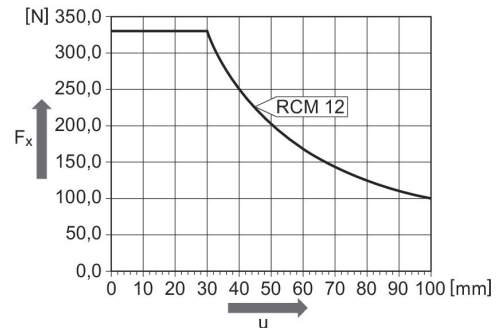

Movement into end position $90^\circ/180^\circ$

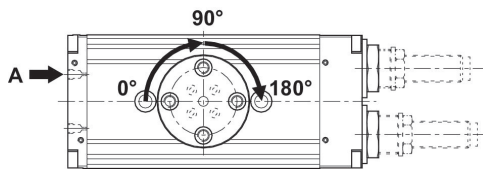

Movement into end position 0°

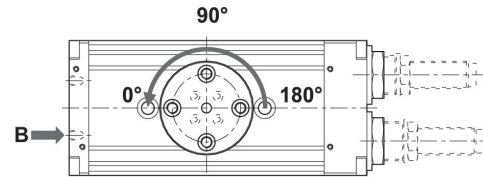

Maximum permissible radial force F_y [N] as a function of v [mm]

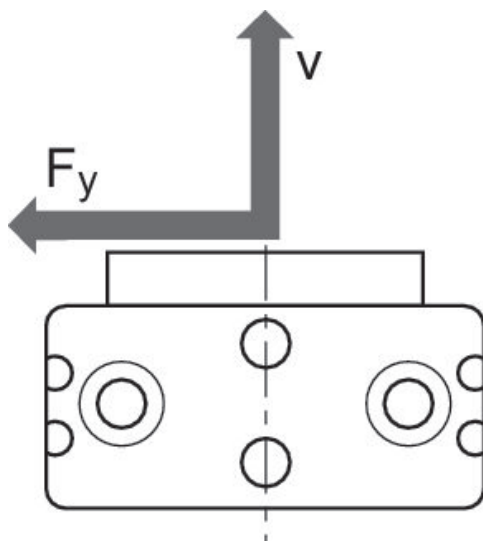

Maximum permissible axial force F_x [N] as a function of u [mm]

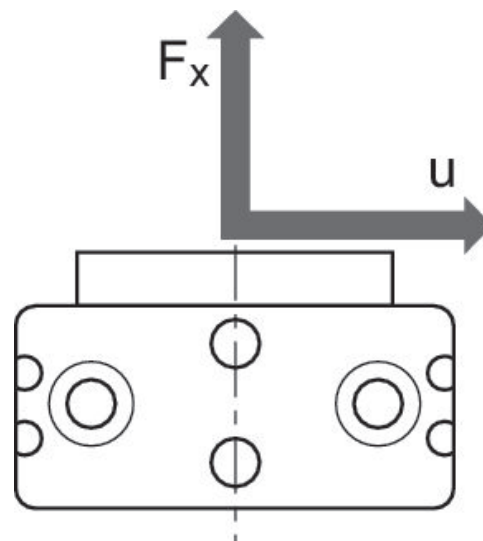

R412000369

Setting range for end positions 0° / 90° / 180°

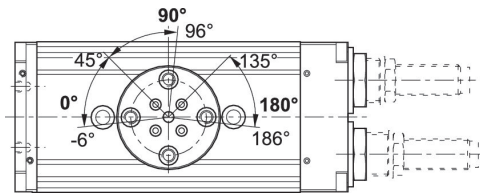

Maximum permissible radial force F_y [N] as a function of v [mm]
RCM 12

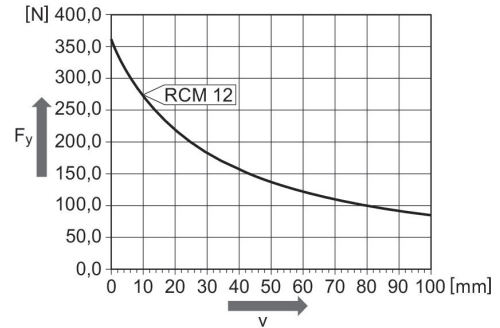

Part No.	Ø D6 ±0,02	Ø D7 k6	Ø D8	Ø D9	Ø D10	Ø D11	Ø D13 k6	H13 +0,2	H14 +0,2
R412000369	25	7	M4	10	5.1	M5	9	1.6	2.1
R412000370	25	7	M4	10	5.1	M5	9	1.6	2.1

Part No.	L9	L10 ±0,02	T5
R412000369	40	60	8.5
R412000370	40	60	8.5