

Rotary Compact Module, Series RCM-SE

2024-04-05

R412000381

The AVENTICS Series RCM with its rotary modules can perform all standardized rotary and swivel movements. These modules can be installed directly on mini slides and are equipped with mechanical grippers.

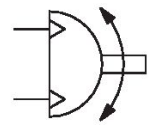
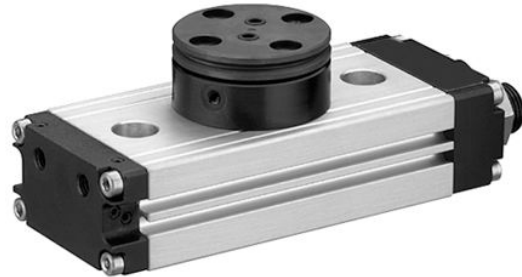

Technical data

Industry	Industrial
Diameter	16 mm
Compressed air connection	M5
Magnetic piston	with magnetic piston
Rotary compact module version	Double piston with rack
Easy2Combine	capable
Frame size	RCM-16
air duct	with air duct
Number of air ducts	4
Theoretical torque at	6 bar
Min. swivel times	0.2 s
Air consumption per rotation	10.36 cm ³
Max. permissible axial bearing load	490 N
Radial shaft load	400 N
Max. permissible mass moment of inertia	1.6 kg cm ²
Theoretical torque	1.7 Nm
Repetitive precision	0.2 °
Cushioning	elastic
Min. angle of rotation	0 °
Max. angle of rotation	90 °
Min. working pressure	2 bar
Max. working pressure	8 bar
Min. ambient temperature	5 °C
Max. ambient temperature	60 °C
Min. medium temperature	5 °C
Max. medium temperature	60 °C

R412000381

Medium	Compressed air
Min. oil content of compressed air	0 mg/m ³
Max. oil content of compressed air	1 mg/m ³
Max. particle size	5 µm
Weight	0.76 kg

Material

Housing material	Aluminum
Surface housing	anodized
Material front cover	Aluminum
Surface cover	black anodized
Material base	Aluminum
Surface base	black anodized
Seal material	Acrylonitrile butadiene rubber
Material axis	Steel, chrome-plated
Surface axis	hardened
Material rotary flange	Steel, chrome-plated
Surface rotary flange	hardened
Part No.	R412000381

Technical information

The pressure dew point must be at least 15 °C less than ambient and medium temperature and may not exceed 3 °C.

The oil content of compressed air must remain constant during the life cycle.

Use only the approved oils from AVENTICS. Further information can be found in the “Technical information” document (available in <https://www.emerson.com/en-us/support>).

Rotary Compact Module, Series RCM-SE

2024-04-05

R412000381

RCM-16/.../-25

RCM-...-SE-AP

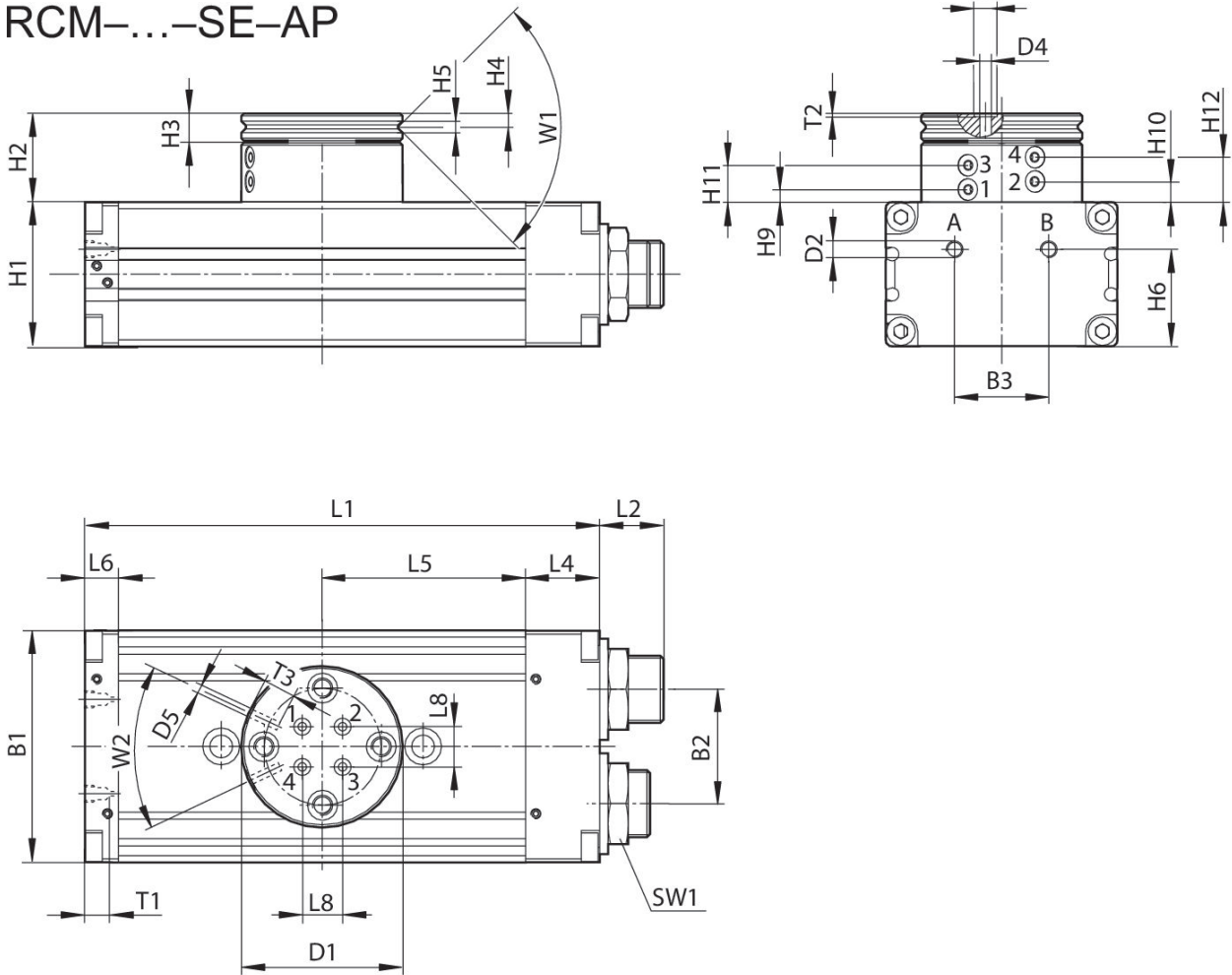

T1 = depth of thread

Part No.	B1	B2	B3	Ø D1	Ø D2	Ø D3	Ø D4	Ø D5	H1
R412000381	52	24	20	40	M5	5	2.5	M3	32
R412000382	52	24	20	40	M5	5	2.5	M3	32
R412000383	58	30	20	42	M5	5	2.5	M3	37
R412000384	58	30	20	42	M5	5	2.5	M3	37
R412000385	69	34	28	48	M5	5	2.5	M3	43
R412000386	69	34	28	48	M5	5	2.5	M3	43

Part No.	H2	H3	H4	H5	H6	H9 ±0,2	H10 ±0,2	H11 ±0,2	H12 ±0,2
R412000381	25.5	7	3.3	2.5	21	3.9	6.5	11.1	13.7
R412000382	25.5	7	3.3	2.5	21	3.9	6.5	11.1	13.7
R412000383	26	7	3.3	3	26	4.4	7	11.6	14.2

Rotary Compact Module, Series RCM-SE

2024-04-05

R412000381

Part No.	H2	H3	H4	H5	H6	H9 ±0,2	H10 ±0,2	H11 ±0,2	H12 ±0,2
R412000384	26	7	3.3	3	26	4.4	7	11.6	14.2
R412000385	26.5	8	4	3	29	3.9	6.5	11.1	13.7
R412000386	26.5	8	4	3	29	3.9	6.5	11.1	13.7

Part No.	L1	L2	L4	L5	L6	L8	SW1	T1	T2
R412000381	108	15	18	40	10	6	19	4	0.7
R412000382	108	15	18	40	10	6	19	4	0.7
R412000383	114	15	19	43	9	10	19	4	0.7
R412000384	114	15	19	43	9	10	19	4	0.7
R412000385	153	19	22	60.5	10	12	23	4	0.7
R412000386	153	19	22	60.5	10	12	23	4	0.7

Part No.	T3	W1	W2
R412000381	4	90°	50°
R412000382	4	90°	50°
R412000383	4	90°	50°
R412000384	4	90°	50°
R412000385	4	90°	50°
R412000386	4	90°	50°

Mounting and assembly RCM-8/-16/-20/-25

Movement into end position 90°/180°

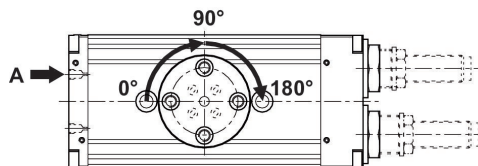
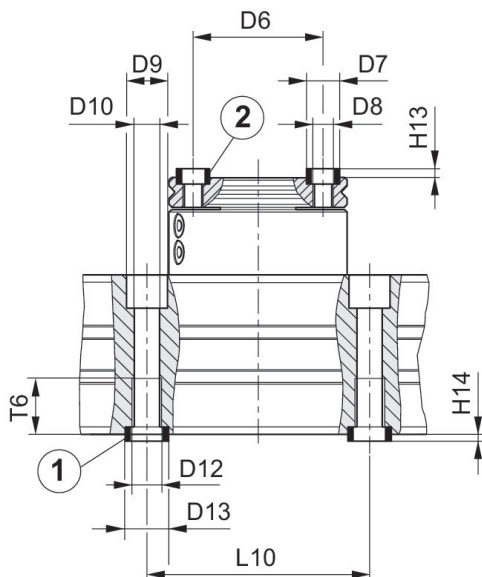

1) centering sleeve, included in the scope of delivery 2) centering sleeve

Movement into end position 0°

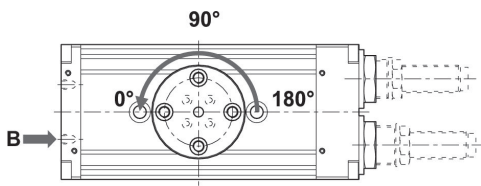

Maximum permissible radial force F_y [N] as a function of v [mm]

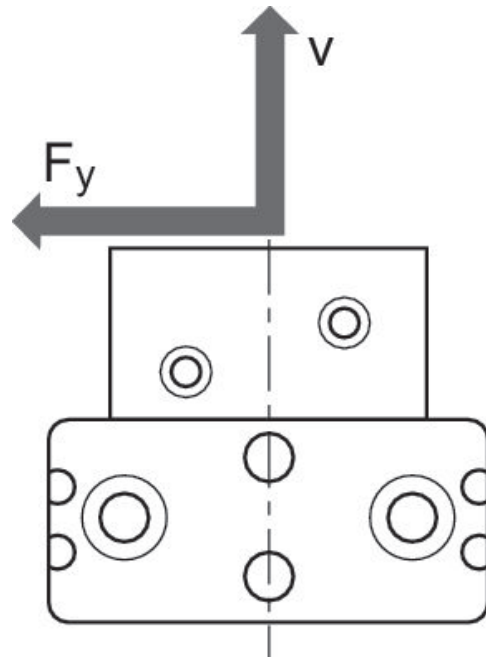

Maximum permissible radial force F_y [N] as a function of v [mm]

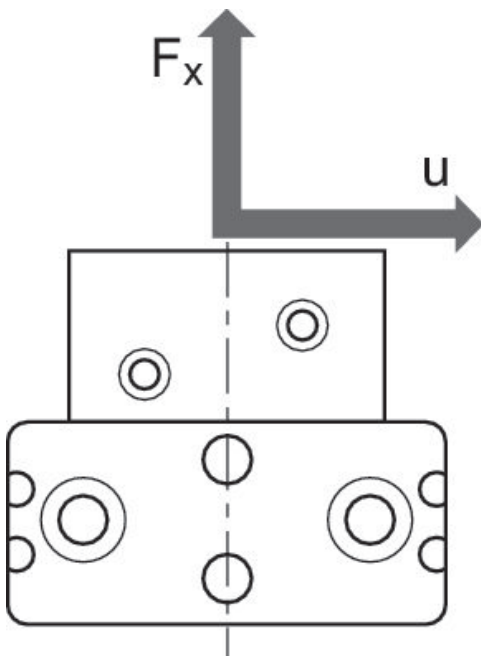

Setting range for end positions 0° / 90° / 180°

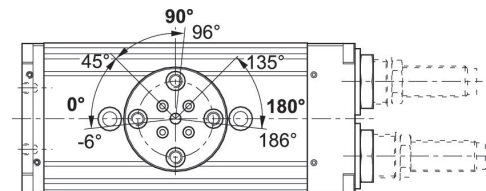

R412000381

Maximum permissible axial force F_x
[N] as a function of u [mm]

RCM 16 – 25

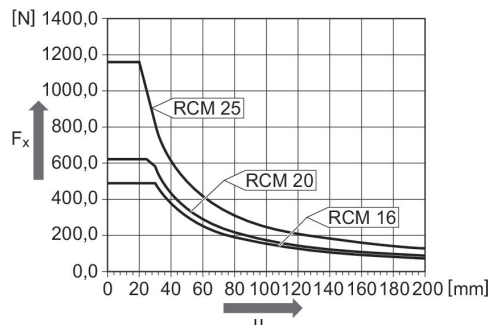

Part No.	Ø D6 ±0,02	Ø D7 k6	Ø D8	Ø D9	Ø D10	Ø D12	Ø D13 k6	H13 +0,2	H14 +0,2
R412000381	30	7	M5	10	5	M6	9	1.6	2.1
R412000382	30	7	M5	10	5	M6	9	1.6	2.1
R412000383	30	7	M5	11	6.8	M8	12	1.6	2.1
R412000384	30	7	M5	11	6.8	M8	12	1.6	2.1
R412000385	35	9	M6	11	6.8	M8	12	2.1	2.1
R412000386	35	9	M6	11	6.8	M8	12	2.1	2.1

Part No.	L10 ± 0,02	T6
R412000381	60	11.1
R412000382	60	11.1
R412000383	60	15.1
R412000384	60	15.1
R412000385	60	15.1
R412000386	60	15.1