

## AVENTICS Series SA1 Industrial shock absorbers

The AVENTICS Series SA1 industrial shock absorbers decelerate reliably moving masses and thereby increase process speed, production quality, the service life of production facilities and reduce operating noise.



## Technical data

Industry	Industrial
Type	SA1-MC
Mounting thread	M12x1
Stroke	10 mm
Max. energy absorption/stroke	14 Nm
Max. energy absorption/hour	30000 Nm
Cushioning	self-compensating
Medium	Oil
Min. ambient temperature	-20 °C
Max. ambient temperature	80 °C
Effective mass $m_e$ min.	1.5 kg
Effective mass $m_e$ max.	7.7 kg
Min. return spring force	3.5 N
Max. return spring force	7 N
Mounting	Clamping flange
Weight	0.06 kg

## Material

Material cylinder tube	Steel, chrome-plated
------------------------	----------------------

# Industrial shock absorber, Series SA1-MC

R412010302

Series SA1

2024-01-10

Surface cylinder tube	salt bath nitrocarburized
Material piston rod	Stainless Steel
Surface piston rod	ground and hardened
Material sealing for piston rod	Acrylonitrile butadiene rubber
Material stop	Polyurethane
Material clamping flange	Steel, chrome-plated
Surface clamping flange	Steel, chrome-plated
Part No.	R412010302

## Dimensions

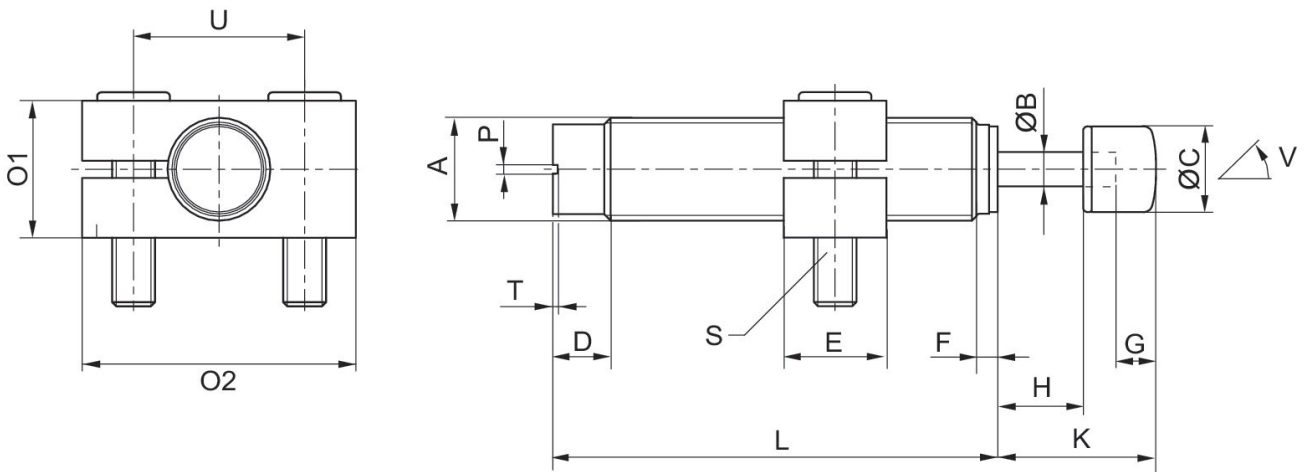

A = mounting thread  
V = tilt

Part No.	Type	Mounting thread	ØB	ØC	D	E	F	G	H
R412010301	SA1-MC	M12x1	4	10	6	12	2.5	4	10
R412010302	SA1-MC	M12x1	4	10	6	12	2.5	4	10
R412010303	SA1-MC	M12x1	4	10	6	12	2.5	4	10

Part No.	K	L	O1	O2	P	S	T	U	W [°]
R412010301	18.5	52	32	16	1	M5x20	0.6	20	2
R412010302	18.5	52	32	16	1	M5x20	0.6	20	2
R412010303	18.5	52	32	16	1	M5x20	0.6	20	2