

## AVENTICS Series SA1 Industrial shock absorbers

The AVENTICS Series SA1 industrial shock absorbers decelerate reliably moving masses and thereby increase process speed, production quality, the service life of production facilities and reduce operating noise.



### Technical data

Industry	Industrial
Type	SA1-MC
Mounting thread	M14x1,5
Stroke	14 mm
Max. energy absorption/stroke	30 Nm
Max. energy absorption/hour	50000 Nm
Cushioning	self-compensating
Medium	Oil
Min. ambient temperature	-20 °C
Max. ambient temperature	80 °C
Effective mass $m_e$ min.	3.5 kg
Effective mass $m_e$ max.	17 kg
Min. return spring force	13 N
Max. return spring force	23 N
Mounting	Lock nut
Weight	0.05 kg

### Material

Material cylinder tube	Steel, chrome-plated
------------------------	----------------------

# Industrial shock absorber, Series SA1-MC

Series SA1

R412010304

2024-01-10

Surface cylinder tube	salt bath nitrocarburized
Material piston rod	Stainless Steel
Surface piston rod	ground and hardened
Material lock nut	Steel, chrome-plated
Surface lock nut	salt bath nitrocarburized
Scraper material	Polyurethane
Part No.	R412010304

## Dimensions

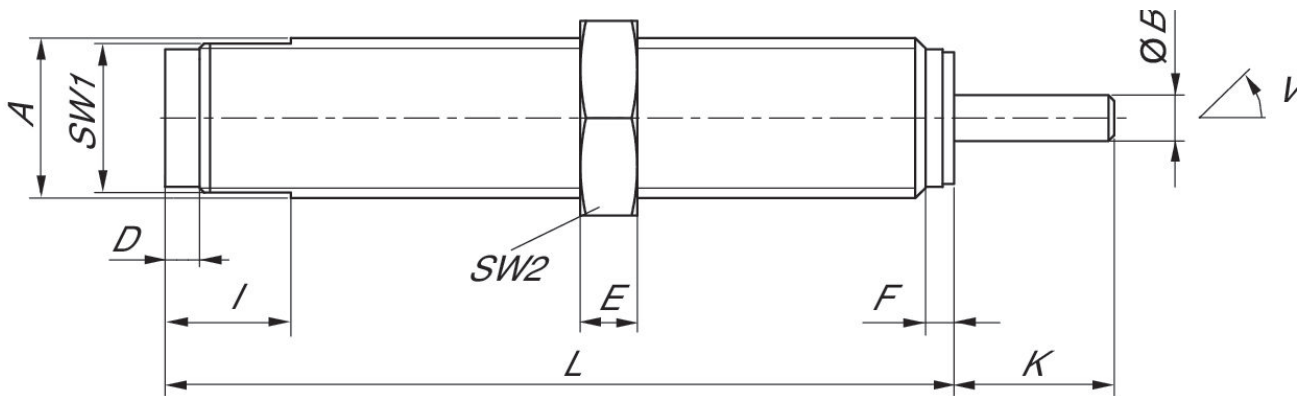

A = mounting thread  
V = tilt

Part No.	Type	Mounting thread	ØB	D	E	F	I	K	L
R412010304	SA1-MC	M14x1,5	4	3	5	2.5	11	14	69
R412010305	SA1-MC	M14x1,5	4	3	5	2.5	11	14	69
R412010306	SA1-MC	M14x1,5	4	3	5	2.5	11	14	69

Part No.	SW1	SW2	W [°]
R412010304	13	17	4
R412010305	13	17	4
R412010306	13	17	4