

AVENTICS™ Series ST6-SM Distance measuring sensors

The AVENTICS Series ST6-SM are distance measuring sensors, which ensure a continuous detection of the piston movements in measuring ranges up to 50 mm. IO-Link allows setting of 8 switching zero point. The compact sensors of 32,5 mm are easy to mount in the 6 mm t-slot. The actuator diagnosis function of the sensor uses performance data such as piston velocity, piston travel or number of piston strokes to make the processes in pneumatic drives visible.

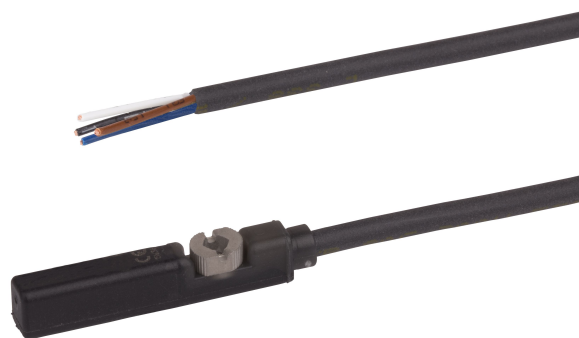

Technical data

Industry	Industrial
Electrical connection type	open cable ends
Electrical connection number of poles	4-pin
Cable	with cable
Cable length	2 m
Slot width	6 mm groove
Operational voltage	13-30 V DC
Repetitive precision max. measuring range	typ. 0,05 mm @25°C
Output signal	0 - 10 V DC, IO-Link
Certificates	UL (Underwriters Laboratories)
Protection class	IP67
Min. ambient temperature	-20 °C
Max. ambient temperature	70 °C
Resolution IO-Link typ.	0,01 mm
Resolution Analog typ.	0,014 mm
Linearity deviation	0,3 mm
Sampling speed	1 m/s

Sensor, Series ST6-SM

R412028895

Series ST6-SM

2024-05-28

Material

Material

Polyamide fiber-glass reinforced

Material cable sheath

Polyurethane

Part No.

R412028895

Dimensions

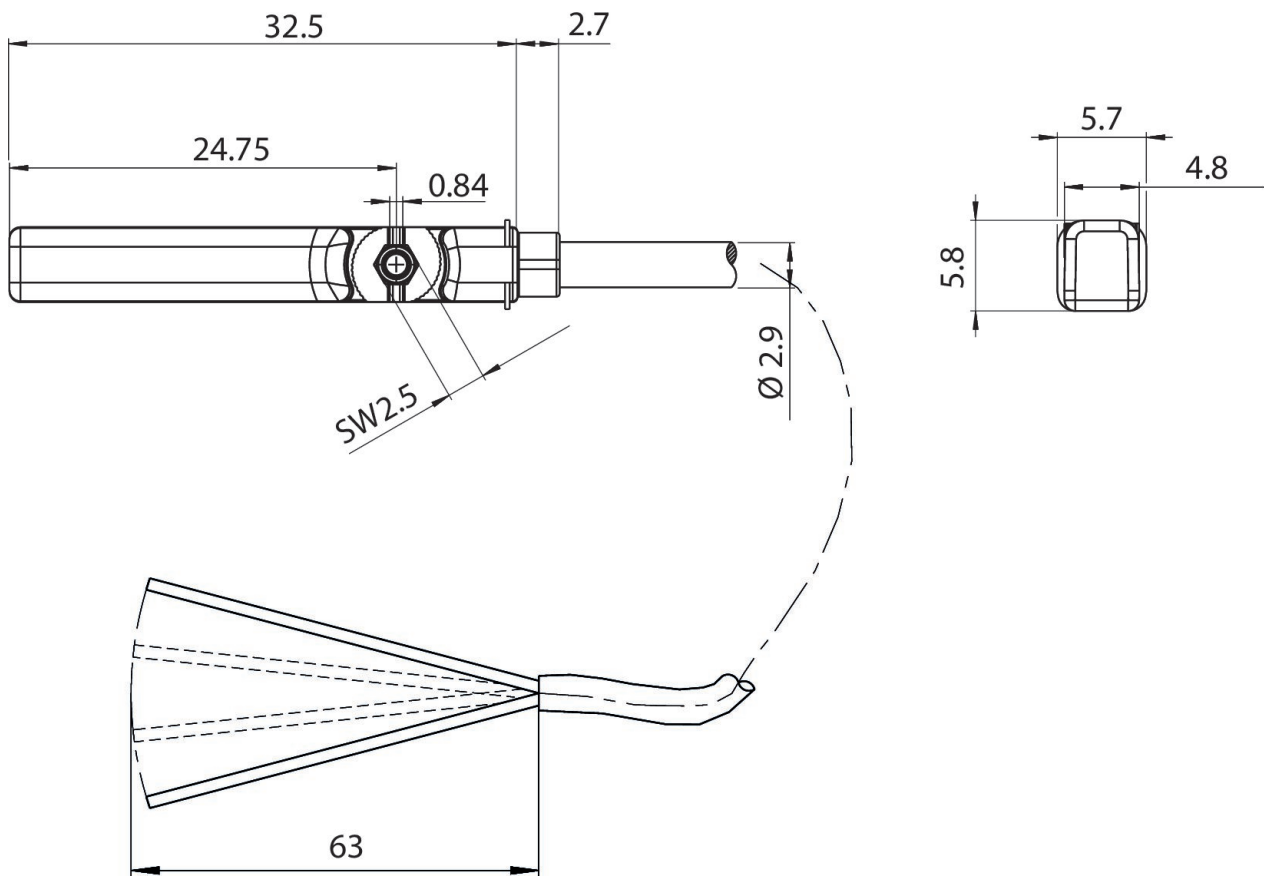

(1) BN=brown (2) WH=white (3) BU=blue (4) BK=black