

Sensor, Series ST6

R412025611

General series information

AVENTICS Series ST6 Magnetic proximity sensors

- The AVENTICS Series ST6 sensors are suitable for mounting in the 6 mm T-slot as well as sensor mounting to the cylinder. They are suited for mounting to all AVENTICS round cylinders, tie rod cylinders, and profile cylinders. With their optimized, compact shape, the sensors can be flush-fit into existing slots and integrated into any machine environment, even with sensor mounting. Retaining ribs on the side of the sensor enable simple mounting, including in hard-to-reach locations or for overhead assembly. The durable mounting screw holds the sensor in the desired position and can withstand shocks or vibrations.

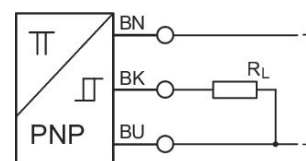
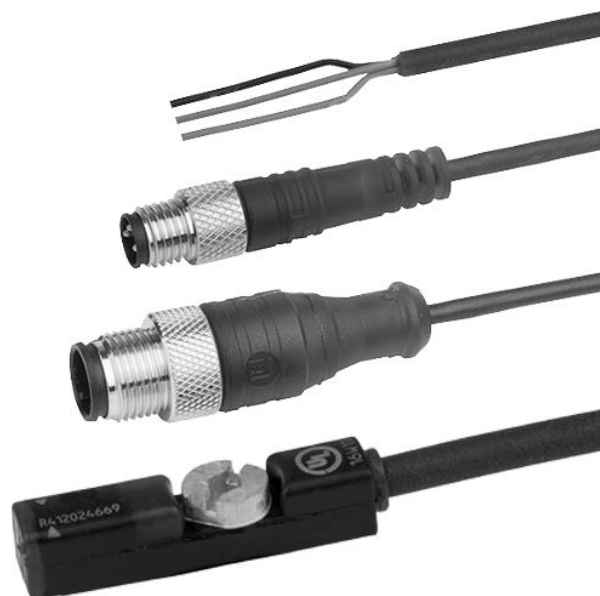

Technical data

Industry

Direct mounting for series

Slot width

Version

Cable

Type of contact

Certificates

Protection class

Min. ambient temperature

Max. ambient temperature

Voltage drop U at I_{max}

DC switching current, max.

Industrial

CCL-IC

6 mm T-slot

1.6 mT response sensitivity

with cable

electronic PNP

RoHS

UL (Underwriters Laboratories)

cULus

IP65

IP67

IP69K

-30 °C

80 °C

≤ 2,5 V

0.13 A

Max. switching frequency	1000 Hz
Switching point precision	±0,1 mT
Switching logic	NO (make contact)
LED status display	Yellow Yellow
Electrical connection 2, type	Plug
Electrical connection 2, thread size	M12
Electrical connection 2, number of poles	3-pin
Operating voltage DC, min.	10 V DC
Operating voltage DC, max.	30 V DC
Short circuit resistance	short circuit resistant
Shock resistance	30 g / 11 ms
Vibration resistance	10 - 55 Hz, 1 mm
Cable length L	0.3 m

Material

Housing material	Polyamide
Material cable sheath	Polyurethane
Material locking screw	Stainless Steel
Part No.	R412025611

Technical information

The pressure dew point must be at least 15 °C less than ambient and medium temperature and may not exceed 3 °C.

The oil content of compressed air must remain constant during the life cycle.

Use only the approved oils from AVENTICS. Further information can be found in the "Technical information" document (available in <https://www.emerson.com/en-us/support>).

Fig. 3

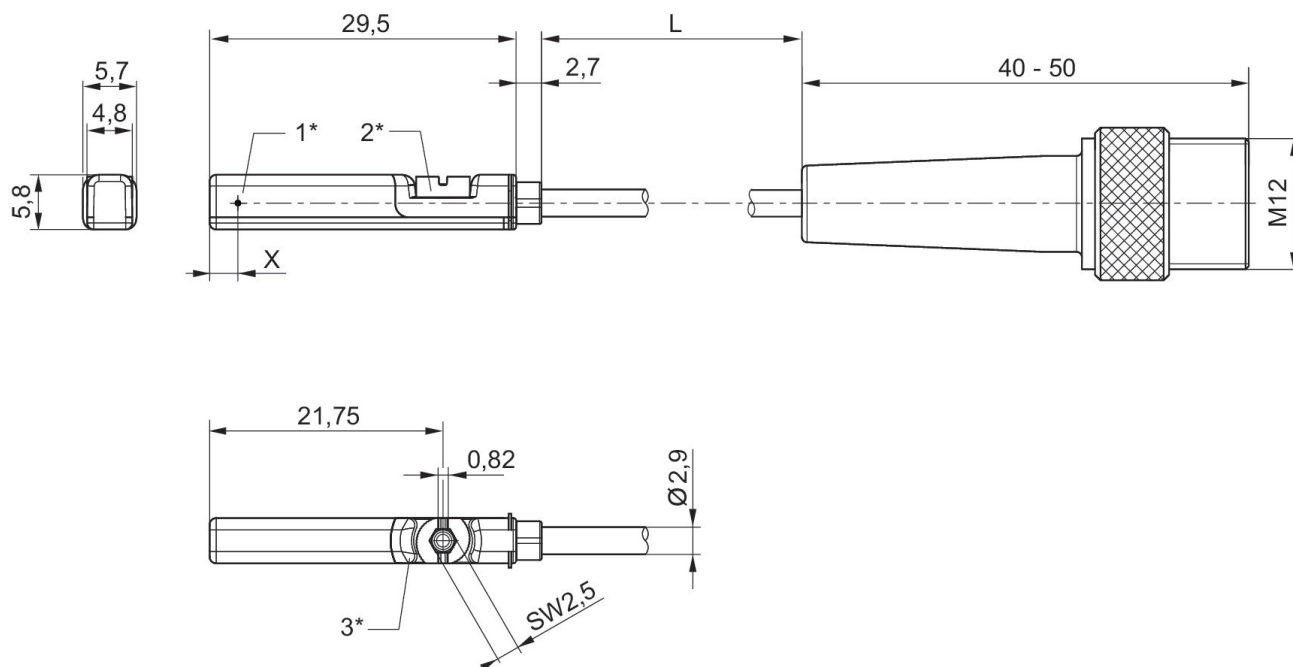

1* = switching point 2* = locking screw 3* = LED window, transparent
L = cable length
X = PNP: 11,6 mm
Pin assignment: 1 = (+) 3 = (-) 4 = (OUT)

Fig. 2

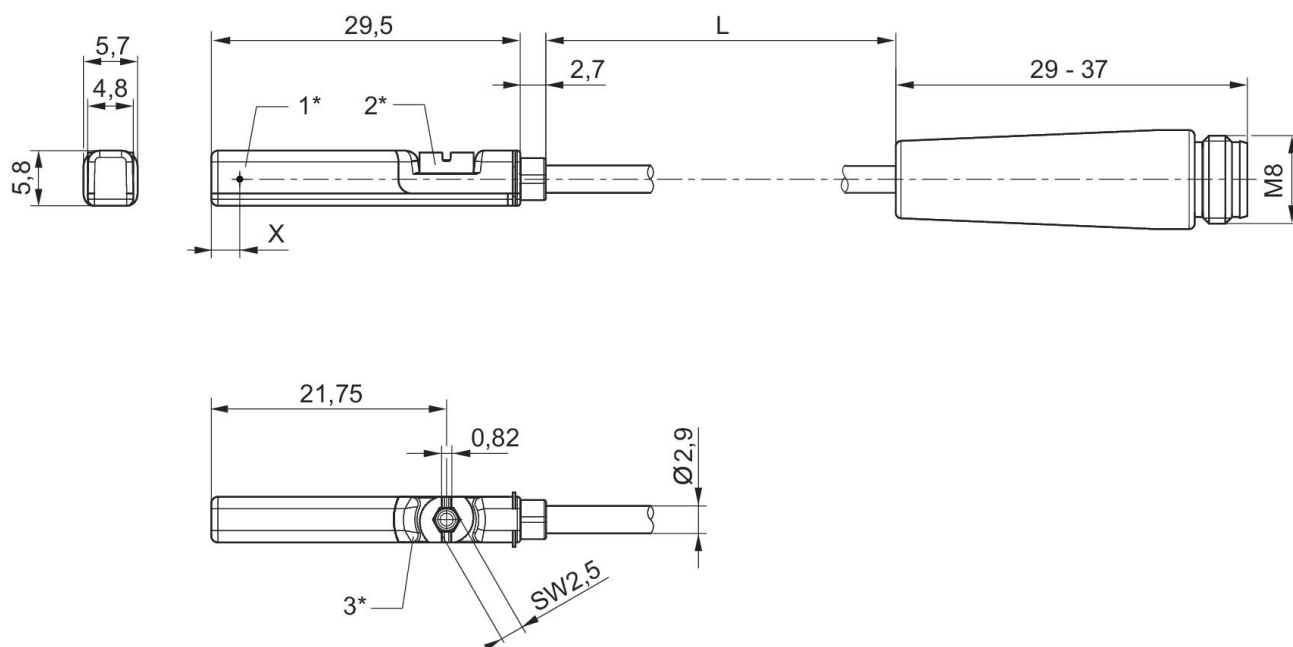

1* = switching point 2* = locking screw 3* = LED window, transparent
L = cable length
X = electronic: 11.6 mm
Pin assignment: 1 = (+) 3 = (-) 4 = (OUT)

Fig. 1

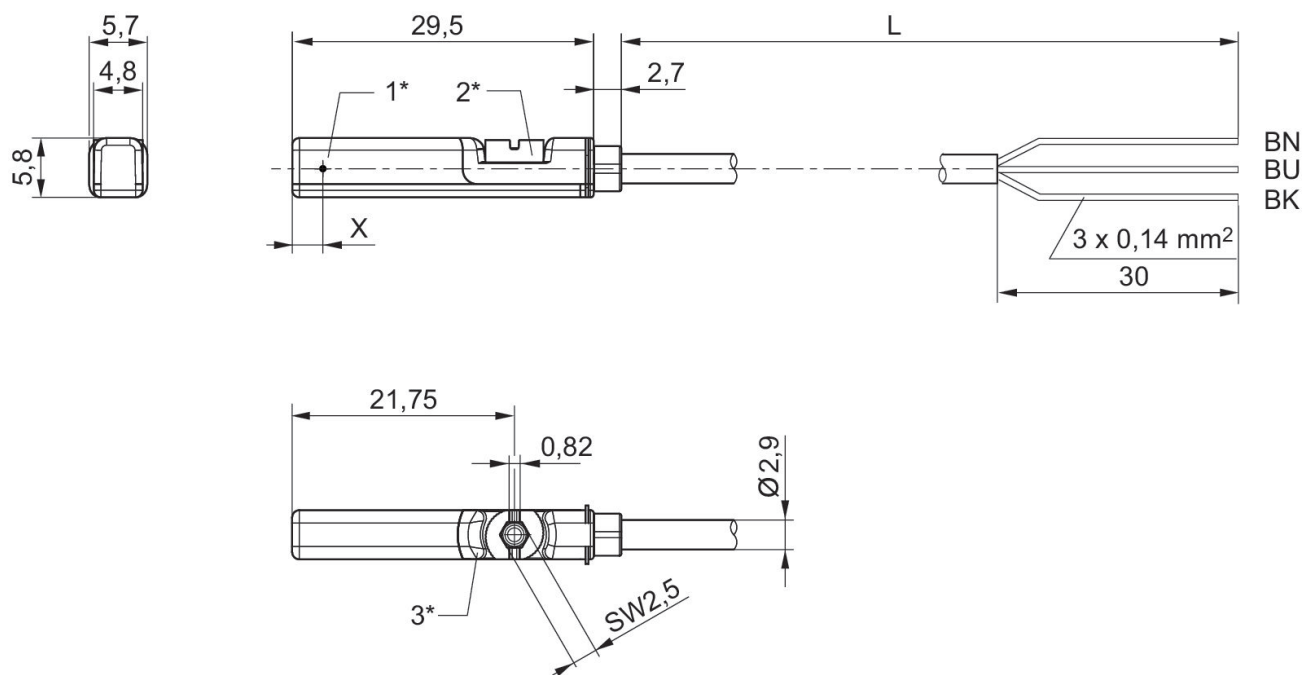

1* = switching point 2* = locking screw 3* = LED window, transparent
L = cable length
BN = brown BK = black BU = blue
X = electronic: 11.6 mm

Pin assignment M8x1 (3-pin)

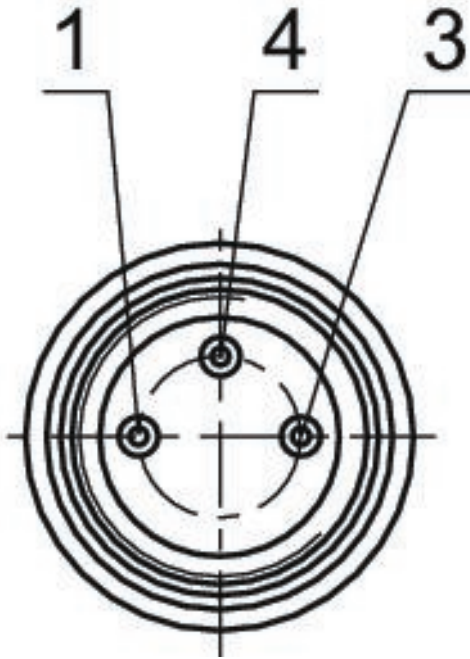

Pin assignments

Pin	Allocation
1	(+)
3	(-)
4	(OUT)