

AVENTICS Series ST9 Magnetic proximity sensors

The AVENTICS Series ST9 sensors are specifically developed for short-stroke cylinders and offer a lean design and practical handling. They slide easily into the 9 mm dovetail nut and can be securely fastened with a single screw. Especially with extremely short cylinders, the electrical connection located at the side of the housing enables easy tightening and removal of the lines.

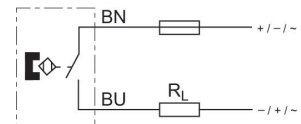

Technical data

Industry	Industrial
Direct mounting for series	KHZ
Slot width	9 mm groove
Type of contact	Reed
Nominal current, actuated state	< 7 mA
Protection class	IP67 IP65
Min. ambient temperature	-20 °C
Max. ambient temperature	80 °C
Voltage drop U at I _{max}	2,1 V + I*Rs
Protective resistor for reed	1,3 Ω
Max. DC switching current	0.13 A
Max. AC switching current	0.2 A
Switching point precision	±0,1 mT
LED status display	Yellow
Electrical connection 2, thread size	Snap Ø8
Electrical connection 2, number of poles	2-pin
Max. operating voltage DC	24 V DC
Max. operational voltage AC	24 V AC
Short circuit resistance	Protected against polarity reversal
Shock resistance	100 g / 11 ms
Vibration resistance	60 g (50 ... 2000 Hz)
Weight	0.01 kg

Material

Housing material	Polyamide
Part No.	0830100460

Technical information

If reed sensors are used, we recommend using a short-circuit protective device (SCPD).

The pressure dew point must be at least 15 °C less than ambient and medium temperature and may not exceed 3 °C.

The oil content of compressed air must remain constant during the life cycle.

Use only the approved oils from AVENTICS. Further information can be found in the "Technical information" document (available in <https://www.emerson.com/en-us/support>).

Dimensions

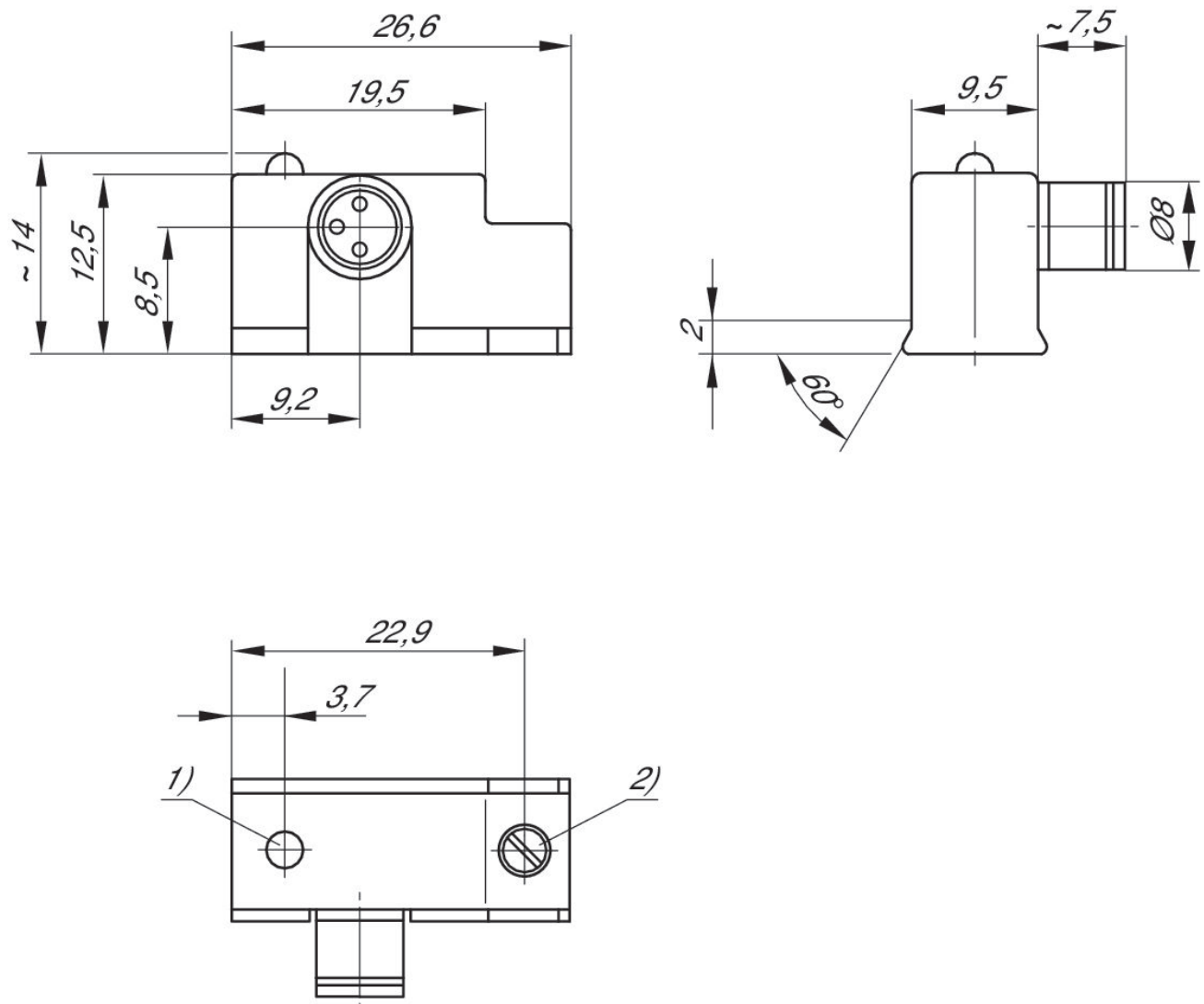

- 1) LED
2) Clamping screw

Pin assignments

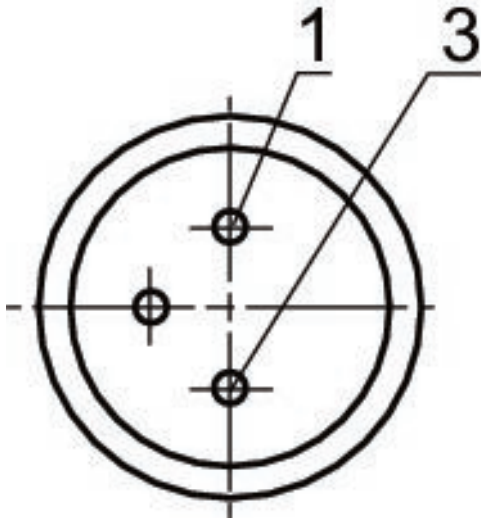

Pin assignments

Pin	Allocation
1	(+)
3	(-)
	EN 60947-5-2:1998