

3/2 directional safety valve, Series SV03

R412027213

2024-11-21

- Rapid response for minimum actuating time
- Position sensors for valve fault monitoring
- Pressure range from 3 - 10 bar
- Internal and external pilot supply as standard
- Category 4 performance level "e" according to ISO 13849-1

AVENTICS Safety valves

AVENTICS dual valves are redundant 3/2 valves for external monitoring that meet the needs and requirements of safe 3/2 valves for the pressurization and exhaust of machines with pneumatic controls in accordance with the ISO 13849-1-2 requirements for safety functions. According to ISO 13849-1, Cat. 4, PL e

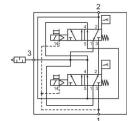

Technical data

Industry	Industrial
Activation	Electrically
Switching principle	3/2
Compressed air connection output	1/4 NPT
Operational voltage DC	24 V
Voltage tolerance DC	-10 % / +10 %
Actuating control	Double Solenoid
Sealing principle	Soft seal
Pilot	Internal
Certificates	DGUV Test cCSAus
Standards	ISO 13849-1, category 4, performance level: e (possible)
Return	With spring return
Compressed air connection input	1/4 NPT
Power consumption DC	1.5 W
Min. working pressure internal	3 bar
Max. working pressure internal	10 bar
Min. working pressure external	0 bar
Max. working pressure external	10 bar

3/2 directional safety valve, Series SV03

R412027213

2024-11-21

Min. control pressure	3 bar
Max. control pressure	10 bar
Min. ambient temperature	4 °C
Max. ambient temperature	50 °C
Min. medium temperature	4 °C
Max. medium temperature	50 °C
Medium	Compressed air
Max. particle size	5 µm
Min. oil content of compressed air	0 mg/m ³
Max. oil content of compressed air	5 mg/m ³
Connector standard	EN 175301-803, form C
Nominal flow Qn 1 to 2	950 l/min
Nominal flow Qn 2 to 3	2150 l/min
Protection class with connection	IP65
Duty cycle	100 %
Typ. switch-on time	35 ms
Typ. switch-off time	80 ms
Type sensor	PNP
Electrical connection for sensor	Plug
Sensor port size	M8
Sensor number of poles	3-pin
Weight	1.64 kg
Housing material	Die-cast aluminum
Seal material	Acrylonitrile butadiene rubber
Part No.	R412027213

3/2 directional safety valve, Series SV03

R412027213

2024-11-21

Technical information

Directional safety valve series SV is delivered and configured for internal control pressure. It can easily be converted to external control pressure. Please refer to the operating instructions. The control pressure must be > 3 bar.

The safety valves are designed in accordance with the requirements listed in ISO 13849-1 and -2. The safety function of the 3/2 safety valve is not only to supply compressed air (pneumatic energy) to the machine/system when the two valve elements are actuated simultaneously, but also to shut off the supply and to exhaust any downstream compressed air when both valves are switched off. A fault in the system where only 1 valve actuates when switching on or only 1 de-actuates when switching off prevents pressurization via port 2 (output) and simultaneously exhausts any air that is already present in port 2 (output). Monitoring of the two proximity sensors by the user's external monitoring system makes it possible to detect these fault situations and to shut off and prevent further electrical energization of the solenoids.

Operating conditions: max. height above mean sea level: 2000 m

Silencer not included in scope of delivery

The min. control pressure must be adhered to, since otherwise faulty switching and valve failure may result!

The pressure dew point must be at least $15\text{ }^{\circ}\text{C}$ less than ambient and medium temperature and may not exceed $3\text{ }^{\circ}\text{C}$.

The oil content of compressed air must remain constant during the life cycle.

Use only the approved oils from AVENTICS. Further information can be found in the "Technical information" document (available in <https://www.emerson.com/en-us/support>).

3/2 directional safety valve, Series SV03

R412027213

2024-11-21

Dimensions

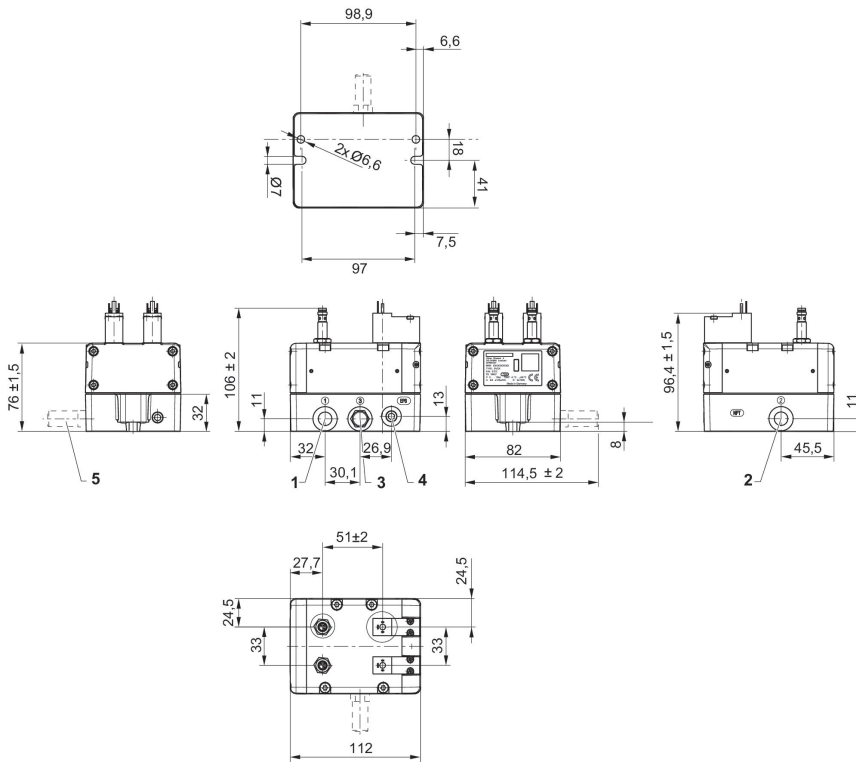

- 1) Port 1 (Input)
- 2) Port 2 (Working pressure)
- 3) Port 3 (Exhaust)
- 4) External pilot G1/4
- 5) Silencer not included in scope of delivery

Safe air supply and exhaust via 3/2 directional valve

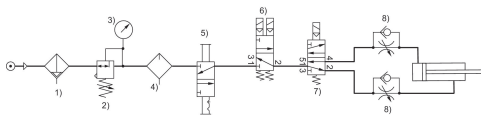

- 1) Filter 2) Pressure regulator 3) Pressure gauge 4) Lubricator 5) Lockout valve 6) Safety exhaust valve, SV series 7) 5/2 pilot valve 8) Check-choke valve

PIN assignment sensor, plug M8 3-pin

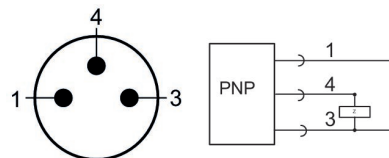

- 1) + 20 ... + 28 VDC
- 3) 0 VDC
- 4) OUT

3/2 directional safety valve, Series SV03

R412027213

2024-11-21

Valve plug connector form C

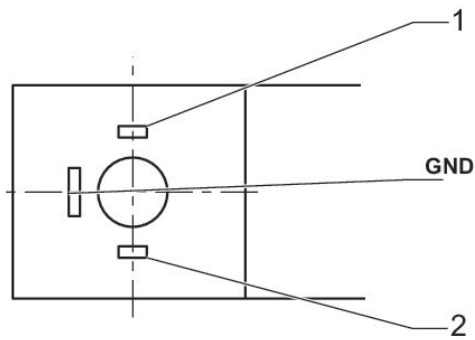

- 1) + 24 / 0 VDC
- 2) 0 / + 24 VDC