

- Rapid response for minimum actuating time
- Position sensors for valve fault monitoring
- Pressure range from 3 - 10 bar
- Internal and external pilot supply as standard
- Category 4 performance level "e" according to ISO 13849-1

## AVENTICS Series SV01/03/05 Safety valves

AVENTICS dual valves are redundant 3/2 valves for external monitoring that meet the needs and requirements of safe 3/2 valves for the pressurization and exhaust of machines with pneumatic controls in accordance with the ISO 13849-1-2 requirements for safety functions. According to ISO 13849-1, Cat. 4, PL e

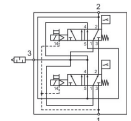

## Technical data

Industry	Industrial
Activation	Electrically
Switching principle	3/2
Compressed air connection output	G 1/2
Operational voltage DC	24 V
Voltage tolerance DC	-10 % / +10 %
Actuating control	Double Solenoid
Sealing principle	Soft seal
Certificates	DGUV Test cCSAus
Standards	ISO 13849-1, category 4, performance level: e (possible)
Valve type	Double spool valve
Return	With spring return
Compressed air connection input	G 1/2
Power consumption DC	1.5 W
Min. working pressure internal	3 bar
Max. working pressure internal	10 bar
Min. working pressure external	0 bar
Max. working pressure external	10 bar

# 3/2 directional safety valve, Series SV05

R412027216

series SV05

2024-11-21

Min. control pressure	3 bar
Max. control pressure	10 bar
Min. ambient temperature	4 °C
Max. ambient temperature	50 °C
Min. medium temperature	4 °C
Max. medium temperature	50 °C
Medium	Compressed air
Max. particle size	5 µm
Min. oil content of compressed air	0 mg/m <sup>3</sup>
Max. oil content of compressed air	5 mg/m <sup>3</sup>
Connector standard	EN 175301-803, form C
Nominal flow Qn 1 to 2	2100 l/min
Nominal flow Qn 2 to 3	6500 l/min
Protection class with connection	IP65
Duty cycle	100 %
Typ. switch-on time	42 ms
Typ. switch-off time	178 ms
Type sensor	PNP
Electrical connection for sensor	Plug
Sensor port size	M8x1
Sensor number of poles	3-pin
Weight	3.25 kg
Housing material	Die-cast aluminum
Seal material	Acrylonitrile butadiene rubber
Part No.	R412027216

## Technical information

Silencer not included in scope of delivery

The min. control pressure must be adhered to, since otherwise faulty switching and valve failure may result!

The pressure dew point must be at least 15 °C less than ambient and medium temperature and may not exceed 3 °C.

The oil content of compressed air must remain constant during the life cycle.

Use only the approved oils from AVENTICS. Further information can be found in the "Technical information" document (available in <https://www.emerson.com/en-us/support>).

Directional safety valve series SV is delivered and configured for internal control pressure. It can easily be converted to external control pressure. Please refer to the operating instructions. The control pressure must be > 3 bar.

# 3/2 directional safety valve, Series SV05

R412027216

series SV05

2024-11-21

## Dimensions

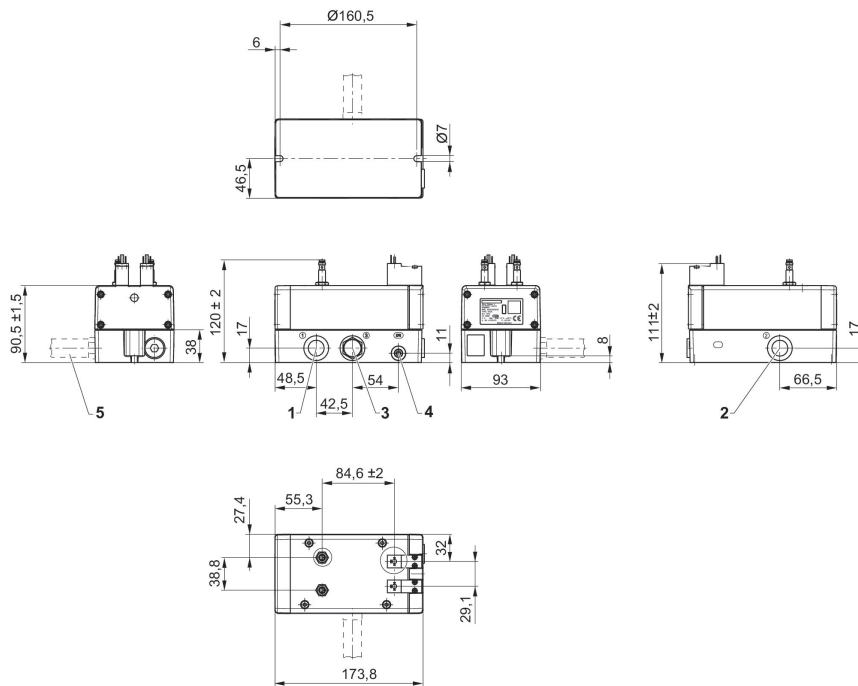

- 1) Port 1 (Input)
- 2) Port 2 (Working pressure)
- 3) Port 3 (Exhaust)
- 4) External pilot G1/8
- 5) Silencer not included in scope of delivery

## Safe air supply and exhaust via 3/2 directional valve

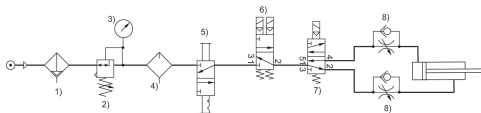

- 1) Filter 2) Pressure regulator 3) Pressure gauge 4) Lubricator 5) Lockout valve 6) Safety exhaust valve, SV series 7) 5/2 pilot valve 8) Check-choke valve

## Valve plug connector form C

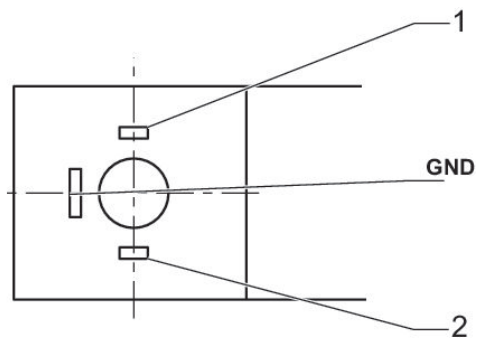

- 1) + 24 / 0 VDC
- 2) 0 / + 24 VDC

# 3/2 directional safety valve, Series SV05

R412027216

series SV05

2024-11-21

## PIN assignment sensor, plug M8

3-pin

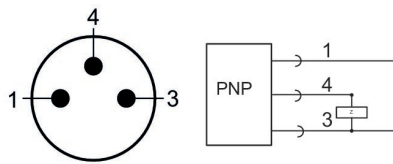

- 
- 1) + 20 ... + 28 VDC
  - 3) 0 VDC
  - 4) OUT