

2x3/2-directional valve, Series TC08, with detent

R422102093

Series
TC08

2024-08-06

- $Q_n = 600 \text{ l/min} \dots 800 \text{ l/min}$
- 2x3/2, 5/2, 5/3 Spool valves with polyamide housing
- Pneumatic connection G1/8, 1/8-27 NPTF
- Working pressure min./max. -0.9/10 bar
- Voltage 12 V DC, 24 V DC, 24 V AC, 110 V AC, 230 V AC
- Electrical connection ISO form C, M8 3-pin; M8 4-pin

AVENTICS Series TC08 Valve systems

The AVENTICS Series TC08 valve system is the perfect choice for applications calling for lightweight valves with high flow rate in a small space. With valves operated either pneumatically or electrically, the valve system can be modularly expanded to up to 12 valves. Valves can be exchanged without dismantling the valve block.

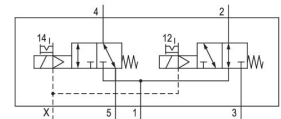

Technical data

Industry	Industrial
Activation	Electrically
Valve type	Spool valve, positive overlapping
Switching principle	2x 3/2 NC/NO, with spring return
Valve function	NC/NO
Actuating control	Double Solenoid
Sealing principle	Soft seal
Connection type	Plate connection Pipe connection
Manual override	with detent
Compressed air connection output	G 1/8
Nominal flow Q_n	600 l/min
Flow conductance b	0.27
Flow conductance C	2.8 l/(s*bar)
Min. working pressure	-0.9 bar
Max. working pressure	10 bar

2x3/2-directional valve, Series TC08, with detent

Series
TC08

R422102093

2024-08-06

Min. control pressure	2.5 bar
Max. control pressure	10 bar
Electrical connection type	Plug
Electrical connection size	M8
Electrical connection number of poles	3-pin
Connector standard	DIN EN 60947-5-2
Protection class acc. to DIN EN 61140	Class III
Protection class with connection	IP65
Operational voltage	24 V DC
Operational voltage DC	24 V
Voltage tolerance DC	-10 % / +10 %
Pilot	External
Coil width	15.6 mm
Pilot valve width	15 mm
LED status display	Yellow
Power consumption DC	2.2 W
Nominal resistance	280 Ω
Duty cycle	100 %
Typ. switch-on time	10 ms
Typ. switch-off time	14 ms
Blocking principle	Plate principle
Can be assembled into blocks	Can be assembled into blocks
Min. ambient temperature	-10 °C
Max. ambient temperature	50 °C
Min. medium temperature	-10 °C
Max. medium temperature	50 °C
Medium	Compressed air
Min. oil content of compressed air	0 mg/m ³
Max. oil content of compressed air	5 mg/m ³
Max. particle size	5 μm
Weight	0.167 kg
Material	
Housing material	Polyamide fiber-glass reinforced

2x3/2-directional valve, Series TC08, with detent

Series
TC08

R422102093

2024-08-06

Seal material	Acrylonitrile butadiene rubber Polyurethane
Material threaded bushing	Brass Die cast zinc
Material front plate	Polyamide fiber-glass reinforced
Part No.	R422102093

Technical information

The min. control pressure must be adhered to, since otherwise faulty switching and valve failure may result!

The pressure dew point must be at least 15 °C less than ambient and medium temperature and may not exceed 3 °C.

The oil content of compressed air must remain constant during the life cycle.

Use only the approved oils from AVENTICS. Further information can be found in the "Technical information" document (available in <https://www.emerson.com/en-us/support>).

Dimensions

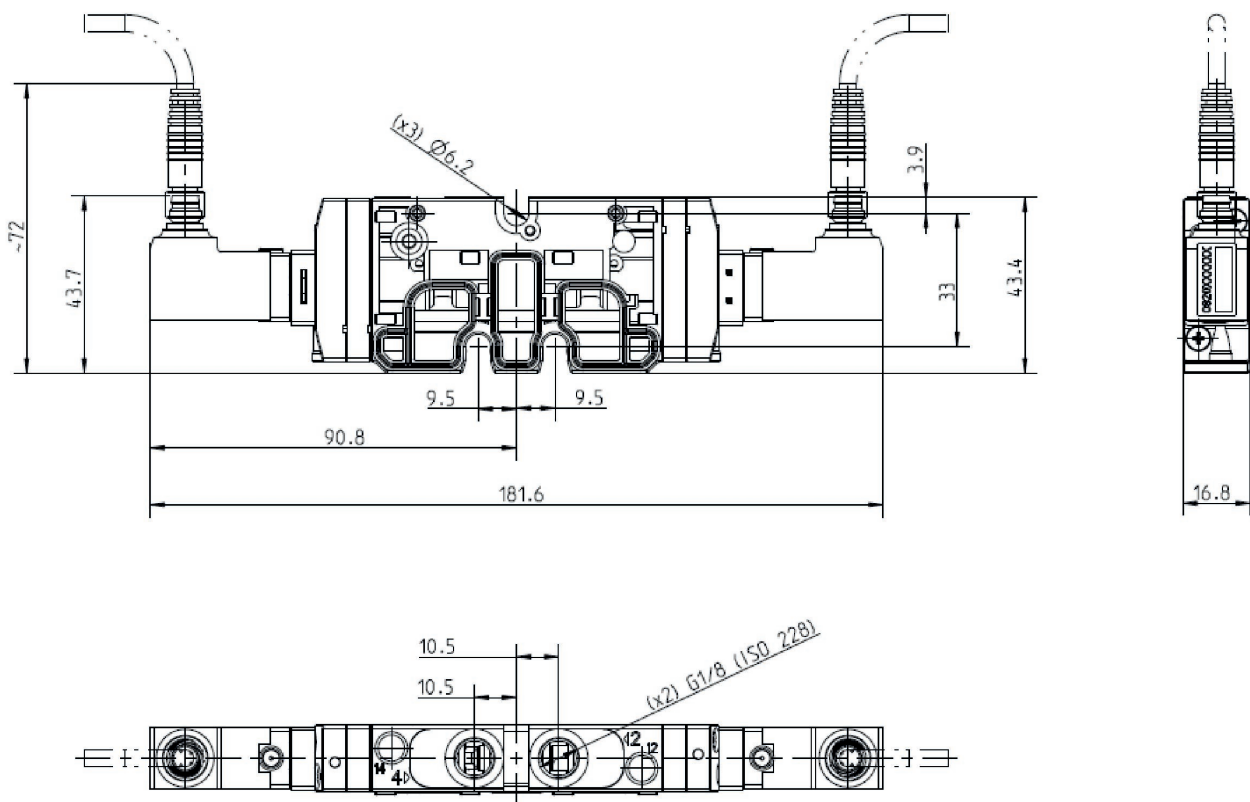

2x3/2-directional valve, Series TC08, with detent

Series
TC08

R422102093

2024-08-06

PIN assignment and cable colors for valve plug connectors

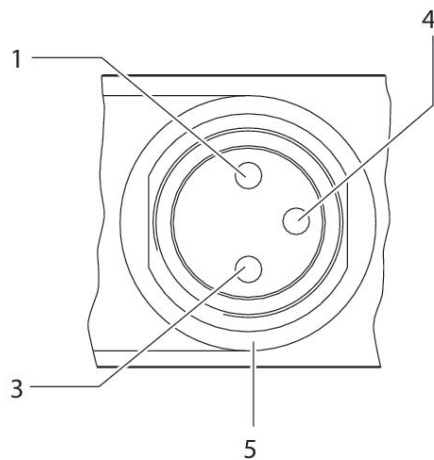

PIN assignment: 1) PIN not assigned 3) 0 V 4) 24 V 5) LED Cable color 1) Brown 3) Blue 4) Black

Note: Bi-polar protective circuit to prevent overvoltage