

5/2-directional valve, Series TC15

2024-05-06

0820258004

Series TC15

Qn = [[1100] l/min] ... [[1500] l/min]

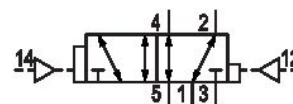

Technical data

Industry	Industrial
Activation	Pneumatically
Valve type	Spool valve, positive overlapping
Sealing principle	Soft seal
Connection type	Pipe connection
Compressed air connection input	G 1/4
Compressed air connection output	G 1/4
Compressed air connection, exhaust	G 1/4
Compressed air connection pilot input	M5
Nominal flow Qn	1500 l/min
Flow conductance b	0.33
Flow conductance C	6.8 l/(s*bar)
Min. working pressure	-0.9 bar
Max. working pressure	10 bar
Min. control pressure	2.5 bar
Max. control pressure	10 bar

5/2-directional valve, Series TC15

2024-05-06

0820258004

Pilot	External
Min. ambient temperature	-10 °C
Max. ambient temperature	50 °C
Min. medium temperature	-10 °C
Max. medium temperature	50 °C
Medium	Compressed air
Min. oil content of compressed air	0 mg/m ³
Max. oil content of compressed air	5 mg/m ³
Max. particle size	5 µm
Mounting on manifold strip	P-strip
Mounting screw tightening torque	2.5 Nm
Weight	0.188 kg

Material

Housing material	Polyamide fiber-glass reinforced
Seal material	Acrylonitrile butadiene rubber
Material, front cover	Polyamide fiber-glass reinforced
Material threaded bushing	Brass Die cast zinc
Surface threaded bushing	chrome-plated nickel-plated
Part No.	0820258004

Technical information

The min. control pressure must be adhered to, since otherwise faulty switching and valve failure may result!

The pressure dew point must be at least 15 °C less than ambient and medium temperature and may not exceed 3 °C.

The oil content of compressed air must remain constant during the life cycle.

Use only the approved oils from AVENTICS. Further information can be found in the "Technical information" document (available in <https://www.emerson.com/en-us/support>).

5/2-directional valve, Series TC15

2024-05-06

0820258004

Dimensions

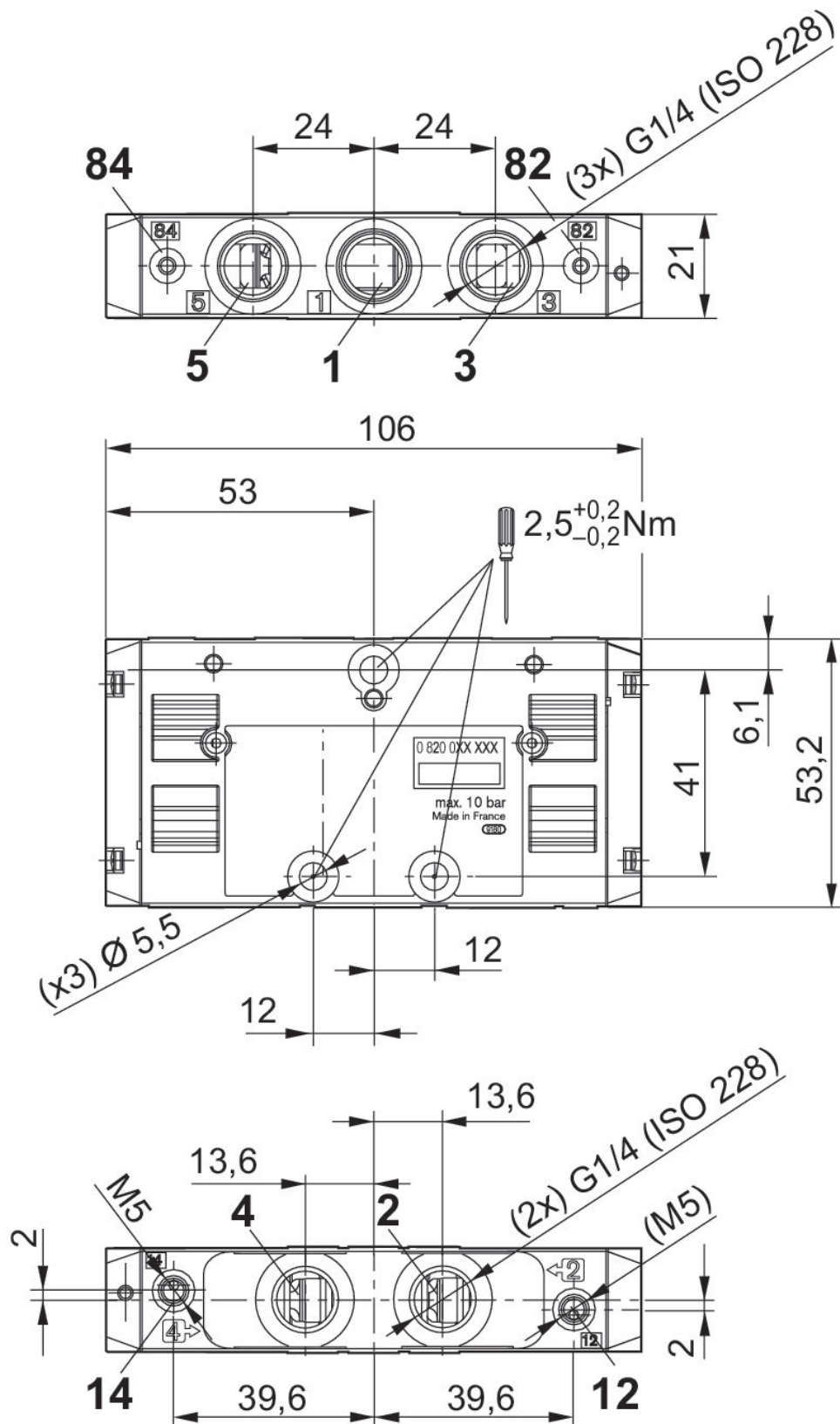

Control pressure

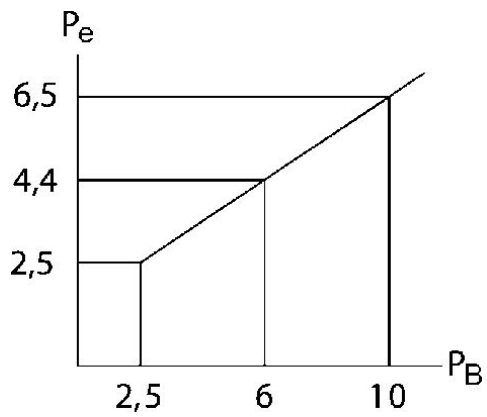

P_e = external control pressure, min.
 P_B = Working pressure