

AVENTICS Series TC15 Directional valves

The AVENTICS Series TC08/TC15 includes a wide range of spool valves with housings made of high-performance polymers with robust and flexible metal inserts. It is designed for flow rate performances from 800 to 1500 l/min. These directional valves are easy to assemble, making them ideal for applications requiring the highest efficiency in limited spaces.

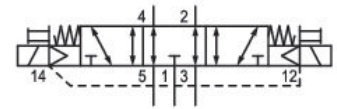

Technical data

Industry	Industrial
Activation	Electrically
Note	Operating voltage 24 V DC
Valve type	Spool valve, positive overlapping
Valve function	Exhausted Center
Actuating control	Double Solenoid
Sealing principle	Soft seal
Connection type	Pipe connection
Manual override	without detent
Compressed air connection input	G 1/4
Compressed air connection output	G 1/4
Compressed air connection, exhaust	G 1/4
Compressed air connection pilot input	M5
Nominal flow Qn	1300 l/min
Flow conductance b	0.31
Flow conductance C	5.9 l/(s*bar)
Min. working pressure	-0.9 bar
Max. working pressure	10 bar
Min. control pressure	3 bar
Max. control pressure	10 bar

5/3-directional valve, Series TC15

0820059361

Series
TC15

2024-05-06

Electrical connection type	Plug
Electrical connection size	M8
Electrical connection number of poles	4-pin
Connector standard	DIN EN 60947-5-2
Protection class acc. to DIN EN 61140	Class III
Protection class with connection	IP65
Operational voltage	24 V DC
Operational voltage DC	24 V
Voltage tolerance DC	-10% / +10%

Pilot	External
Coil width	15.6 mm
Pilot valve width	15 mm
LED status display	Yellow
Power consumption DC	2.2 W
Nominal resistance	280 Ω

Duty cycle	100 %
Typ. switch-on time	12 ms
Typ. switch-off time	13 ms

Min. ambient temperature	-10 °C
Max. ambient temperature	50 °C
Min. medium temperature	-10 °C
Max. medium temperature	50 °C
Medium	Compressed air
Min. oil content of compressed air	0 mg/m ³
Max. oil content of compressed air	5 mg/m ³
Max. particle size	5 μ m

Mounting on manifold strip	P-strip
Mounting screw tightening torque	2.5 Nm
Weight	0.279 kg

Material

Housing material	Polyamide fiber-glass reinforced
Seal material	Acrylonitrile butadiene rubber Hydrogenated nitrile butadiene rubber

5/3-directional valve, Series TC15

0820059361

Series
TC15

2024-05-06

Material threaded bushing	Brass Die cast zinc
Material front plate	Polyamide fiber-glass reinforced

Part No. 0820059361

Technical information

The min. control pressure must be adhered to, since otherwise faulty switching and valve failure may result!

The pressure dew point must be at least 15 °C less than ambient and medium temperature and may not exceed 3 °C.

The oil content of compressed air must remain constant during the life cycle.

Use only the approved oils from AVENTICS. Further information can be found in the "Technical information" document (available in <https://www.emerson.com/en-us/support>).

5/3-directional valve, Series TC15

0820059361

Series
TC15

2024-05-06

Dimensions

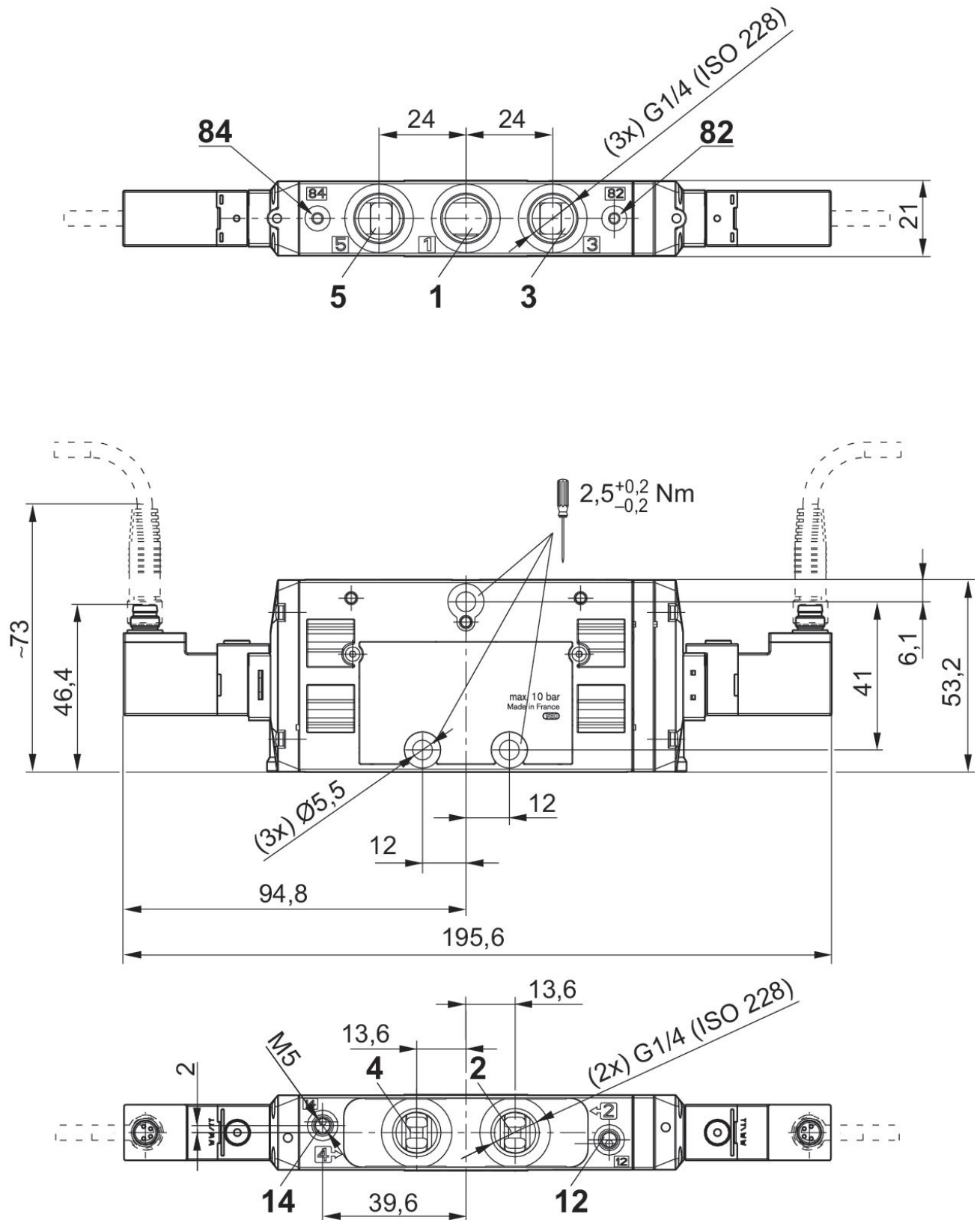

5/3-directional valve, Series TC15

0820059361

Series
TC15

2024-05-06

PIN assignment and cable colors for
valve plug connectors

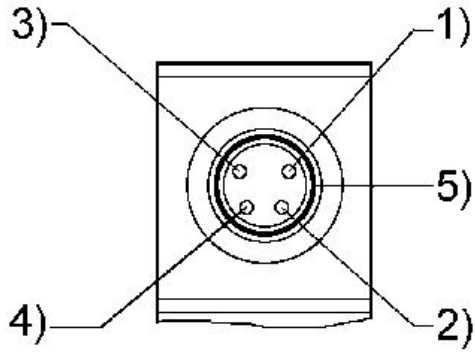

PIN assignment: 1) PIN not assigned 2) PIN not assigned 3) 0 V 4) 24 V 5)
LED Cable colors 1) Brown 2) White 3) Blue 4) Black