

AVENTICS Series TRB Tie rod cylinders (ISO 1552)

The AVENTICS Series TRB (ISO 1552) cylinders are among the most frequently implemented in industries where heavy duty cylinders are required, such as wood and aluminium, steel and automotive, heavy-duty machinery and mining to name just a few.



Technical data

| | |
|--|------------------------------------|
| Industry | Industrial |
| Piston Ø | 40 mm |
| Stroke | 177.8 mm |
| Ports | 1/4 NPT |
| Functional principle | Double-acting |
| Cushioning | Pneumatic adjustable cushioning |
| Magnetic piston | Piston with magnet |
| Environmental requirements | Industry standard ATEX optional |
| Piston rod thread - type | External thread |
| Piston rod thread | 1/2-20 UNF |
| Piston rod | single |
| Scraper | Standard Industry Scraper |
| Pressure for determining piston forces | 6,3 bar |
| Retracting piston force | 660 N |
| Extracting piston force | 790 N |
| Min. ambient temperature | -20 °C |
| Max. ambient temperature | 80 °C |
| Min. working pressure | 2 bar |
| Max. working pressure | 10 bar |

Tie rod cylinder ISO 15552, Series TRB - inch

R480176907

TRB

2024-04-26

| | |
|------------------------------------|---------------------|
| Cushioning length | 19 mm |
| Cushioning energy | 9 J |
| Weight 0 mm stroke | 0.67 kg |
| Weight +10 mm stroke | 0.03 kg |
| Stroke max. | 1900 mm |
| Medium | Compressed air |
| Min. medium temperature | -20 °C |
| Max. medium temperature | 80 °C |
| Max. particle size | 50 µm |
| Min. oil content of compressed air | 0 mg/m ³ |
| Max. oil content of compressed air | 5 mg/m ³ |

Material

| | |
|-----------------------|----------------------|
| Piston rod | Stainless Steel |
| Scraper material | Polyurethane |
| Material tie-rod | Stainless Steel |
| Seal material | Polyurethane |
| Material, front cover | Die-cast aluminum |
| Cylinder tube | Aluminum |
| End cover | Die-cast aluminum |
| Nut for piston rod | Steel, chrome-plated |
| Part No. | R480176907 |

Technical information

The pressure dew point must be at least 15 °C less than ambient and medium temperature and may not exceed 3 °C.

The oil content of compressed air must remain constant during the life cycle.

Use only the approved oils from AVENTICS. Further information can be found in the "Technical information" document (available in <https://www.emerson.com/en-us/support>).

Tie rod cylinder ISO 15552, Series TRB - inch

R480176907

TRB

2024-04-26

Dimensions in inches

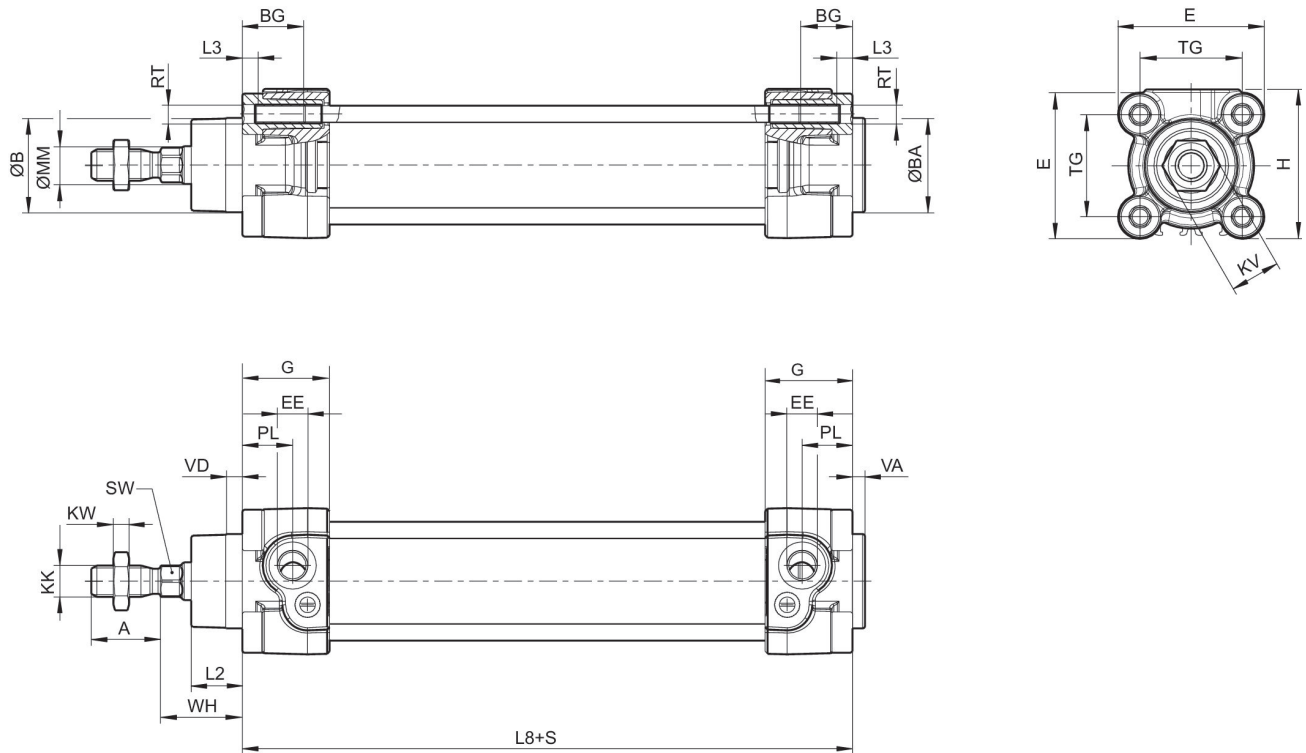

S = stroke

Dimensions in inches

| \varnothing [mm] | \varnothing [inch] | A -0,08 | $\varnothing B$ d11 | $\varnothing BA$ d11 | BG min. | E | EE | KK | G |
|--------------------|----------------------|---------|---------------------|----------------------|---------|------|---------|---------------|------|
| 32 | 1 1/4 | 0.87 | 1.18 | 1.18 | 0.63 | 1.83 | 1/8 NPT | 7/16 - 20 UNF | 1.09 |
| 40 | 1 1/2 | 0.94 | 1.38 | 1.38 | 0.63 | 2.09 | 1/4 NPT | 1/2 - 20 UNF | 1.31 |
| 50 | 2 | 1.26 | 1.57 | 1.57 | 0.63 | 2.56 | 1/4 NPT | 3/4 - 16 UNF | 1.22 |
| 63 | 2 1/2 | 1.26 | 1.77 | 1.77 | 0.63 | 2.95 | 3/8 NPT | 3/4 - 16 UNF | 1.51 |
| 80 | 3 | 1.57 | 1.77 | 1.77 | 0.67 | 3.74 | 3/8 NPT | 3/4 - 16 UNF | 1.51 |
| 100 | 4 | 1.57 | 2.17 | 2.17 | 0.67 | 4.53 | 1/2 NPT | 3/4 - 16 UNF | 1.66 |
| 125 | 5 | 2.13 | 2.36 | 2.36 | 0.79 | 5.51 | 1/2 NPT | 1 - 14 UNF | 2.12 |

| \varnothing [mm] | H | KV | KW | $\varnothing MM$ f8 | PL | L2 | L3 $\pm 0,02$ | L8 | RT |
|--------------------|------|------|------|---------------------|------|------|---------------|-----------------|-----|
| 32 | 1.87 | 0.63 | 0.2 | 0.47 | 0.63 | 0.64 | 0.18 | 3.7 $\pm 0,02$ | M6 |
| 40 | 2.09 | 0.71 | 0.24 | 0.63 | 0.79 | 0.72 | 0.18 | 4.13 $\pm 0,03$ | M6 |
| 50 | 2.56 | 0.94 | 0.31 | 0.79 | 0.75 | 0.98 | 0.18 | 4.17 $\pm 0,03$ | M8 |
| 63 | 2.95 | 0.94 | 0.31 | 0.79 | 0.94 | 0.98 | 0.18 | 4.76 $\pm 0,03$ | M8 |
| 80 | 3.74 | 1.18 | 0.39 | 0.98 | 0.93 | 1.3 | 0 | 5.04 $\pm 0,03$ | M10 |
| 100 | 4.53 | 1.18 | 0.39 | 0.98 | 0.98 | 1.42 | 0 | 5.43 $\pm 0,04$ | M10 |
| 125 | 5.51 | 1.61 | 0.53 | 1.26 | 1.3 | 1.77 | 0 | 6.3 $\pm 0,04$ | M12 |

| \varnothing [mm] | SW | TG | VA -0,04 | VD | WH |
|--------------------|------|-----------------|----------|-----|-----------------|
| 32 | 0.39 | 1.28 $\pm 0,02$ | 0.16 | 0.2 | 1.02 $\pm 0,06$ |

Tie rod cylinder ISO 1552, Series TRB - inch

R480176907

TRB

2024-04-26

| Ø [mm] | SW | TG | VA -0,04 | VD | WH |
|--------|------|-----------|----------|------|-----------|
| 40 | 0.51 | 1.5±0.02 | 0.16 | 0.2 | 1.18±0.06 |
| 50 | 0.67 | 1.83±0.02 | 0.16 | 0.2 | 1.46±0.06 |
| 63 | 0.67 | 2.22±0.03 | 0.16 | 0.2 | 1.46±0.07 |
| 80 | 0.87 | 2.83±0.03 | 0.16 | 0.2 | 1.81±0.07 |
| 100 | 0.87 | 3.5±0.03 | 0.16 | 0.2 | 2.01±0.07 |
| 125 | 1.06 | 4.33±0.04 | 0.24 | 0.28 | 2.56±0.09 |

Cushioning diagram



v_i = Piston velocity [m/s] m = Cushionable mass [kg]

Tie rod cylinder ISO 1552, Series TRB - inch

R480176907

TRB

2024-04-26

Overview drawing

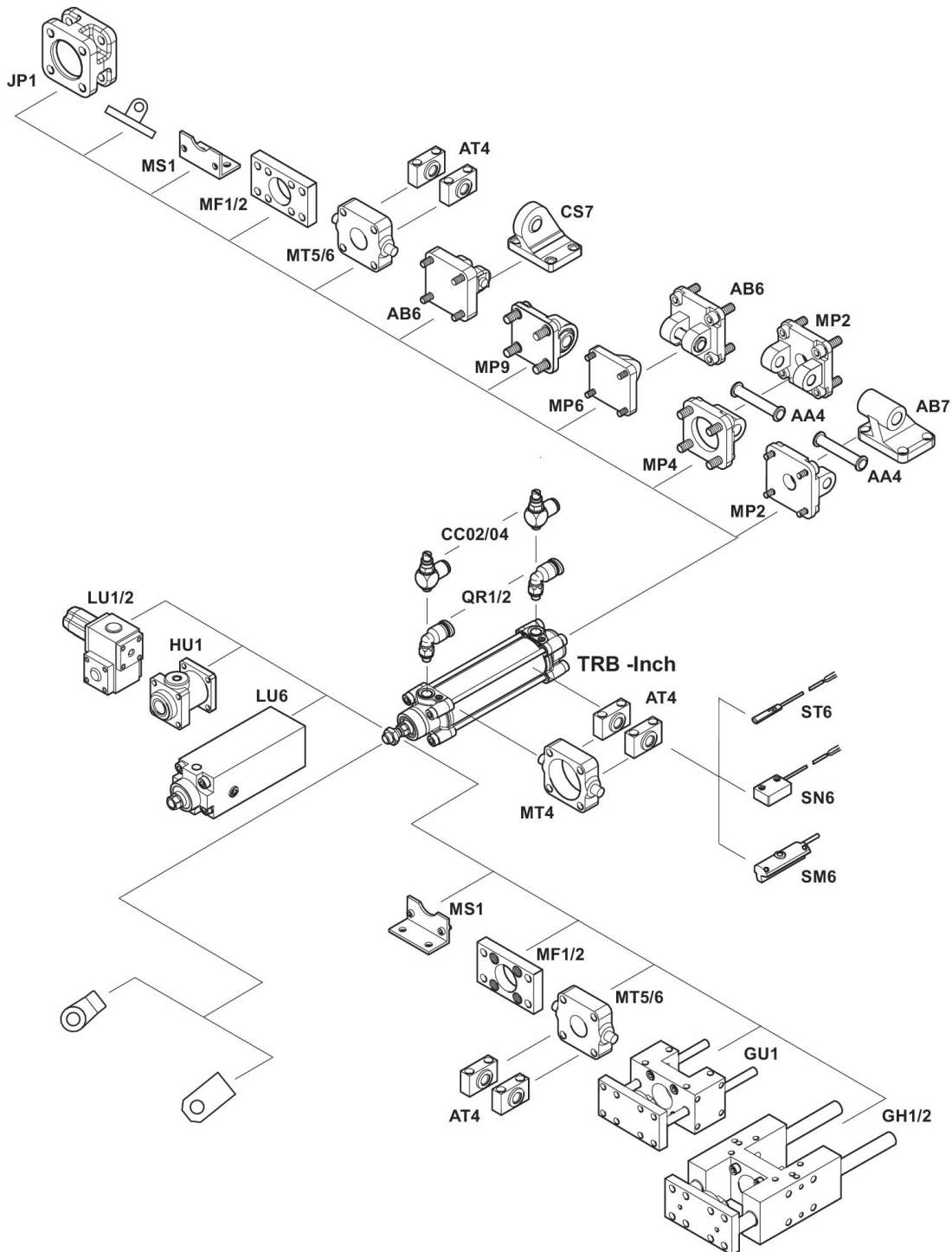

NOTE: This overview drawing is only for orientation to indicate where the various accessory parts can be fastened to the cylinder. The illustration has been simplified for this purpose. It is thus not possible to derive the dimensions from this overview.