

## AVENTICS Series TRB Tie rod cylinders (ISO 1552)

The AVENTICS Series TRB (ISO 1552) cylinders are among the most frequently implemented in industries where heavy duty cylinders are required, such as wood and aluminium, steel and automotive, heavy-duty machinery and mining to name just a few.



### Technical data

|  |                                 |
|--|---------------------------------|
| Industry                               | Industrial                      |
| Standards                              | ISO 15552                       |
| Piston Ø                               | 40 mm                           |
| Stroke                                 | 200 mm                          |
| Ports                                  | G 1/4                           |
| Functional principle                   | Double-acting                   |
| Cushioning                             | Pneumatic adjustable cushioning |
| Magnetic piston                        | Piston with magnet              |
| Environmental requirements             | Industry standard               |
| Piston rod thread - type               | External thread                 |
| Piston rod thread                      | M12x1,25                        |
| Piston rod                             | non-rotating                    |
| Scraper                                | Standard Industry Scraper       |
| Pressure for determining piston forces | 6,3 bar                         |
| Retracting piston force                | 660 N                           |
| Extracting piston force                | 790 N                           |
| Min. ambient temperature               | -20 °C                          |
| Max. ambient temperature               | 80 °C                           |
| Min. working pressure                  | 1.5 bar                         |

# Tie rod cylinder ISO 15552, Series TRB

series TRB

R481602030

2024-04-26

---

|                                    |                     |
|------------------------------------|---------------------|
| Max. working pressure              | 10 bar              |
| Cushioning length                  | 19 mm               |
| Cushioning energy                  | 9 J                 |
| Max. torque for torsion protection | 1.5 Nm              |
| Rotation angle tolerance (±)       | 1.6 °               |
| Weight 0 mm stroke                 | 0.67 kg             |
| Weight +10 mm stroke               | 0.03 kg             |
| Stroke max.                        | 1500 mm             |
| Medium                             | Compressed air      |
| Min. medium temperature            | -20 °C              |
| Max. medium temperature            | 80 °C               |
| Max. particle size                 | 50 µm               |
| Min. oil content of compressed air | 0 mg/m <sup>3</sup> |
| Max. oil content of compressed air | 5 mg/m <sup>3</sup> |

## Material

|                       |                      |
|-----------------------|----------------------|
| Piston rod            | Stainless Steel      |
| Scraper material      | Polyurethane         |
| Material tie-rod      | Stainless Steel      |
| Seal material         | Polyurethane         |
| Material, front cover | Die-cast aluminum    |
| Cylinder tube         | Aluminum             |
| End cover             | Die-cast aluminum    |
| Nut for piston rod    | Steel, chrome-plated |
| Part No.              | R481602030           |

## Technical information

The pressure dew point must be at least 15 °C less than ambient and medium temperature and may not exceed 3 °C.

The oil content of compressed air must remain constant during the life cycle.

Use only the approved oils from AVENTICS. Further information can be found in the “Technical information” document (available in <https://www.emerson.com/en-us/support>).

# Tie rod cylinder ISO 15552, Series TRB

series TRB

R481602030

2024-04-26

## Dimensions

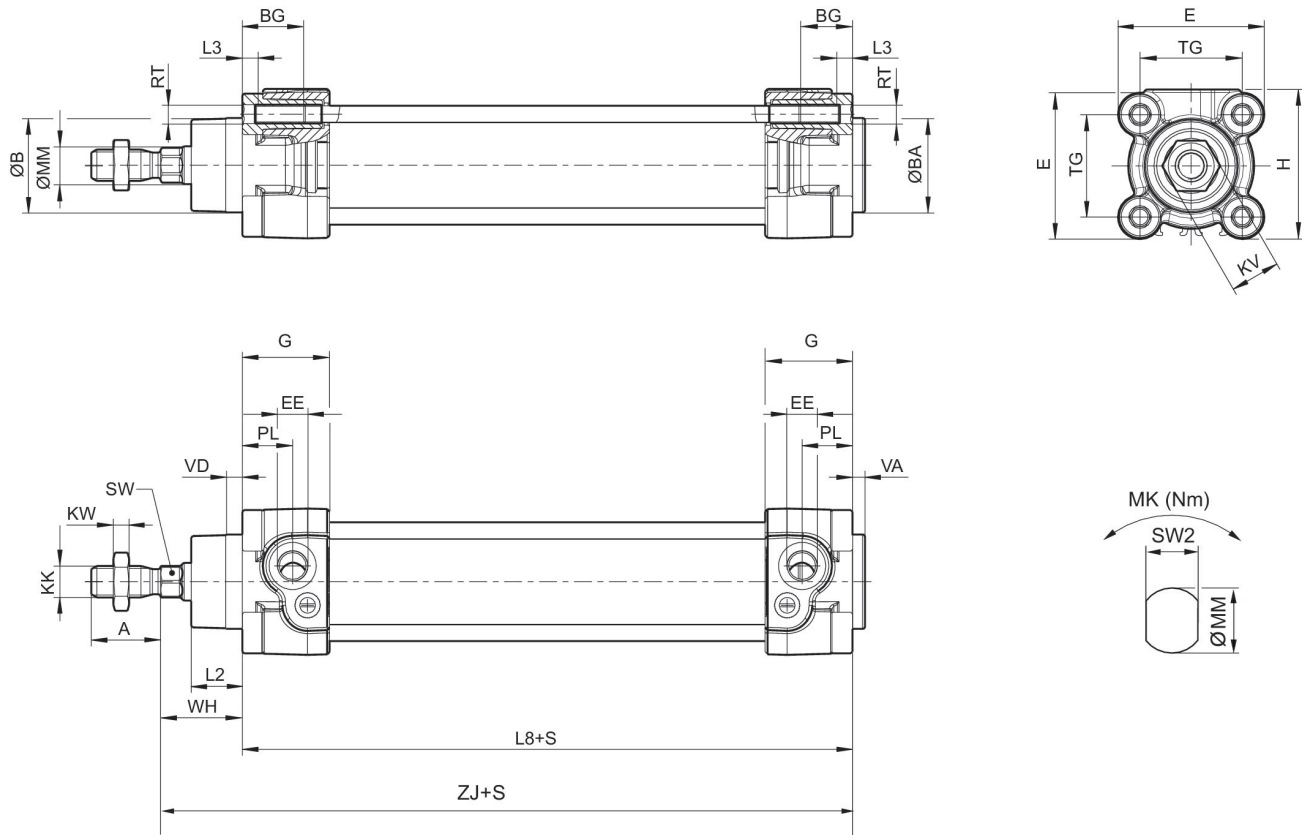

S = stroke

| Piston $\varnothing$ | A -2 | $\varnothing B$ d11 | $\varnothing BA$ d11 | BG min. | E    | EE    | G     | H    | KF  |
|----------------------|------|---------------------|----------------------|---------|------|-------|-------|------|-----|
| 32                   | 22   | 30                  | 30                   | 16      | 46.5 | G 1/8 | 27.75 | 47.5 | M6  |
| 40                   | 24   | 35                  | 35                   | 16      | 53   | G 1/4 | 33.25 | 53   | M8  |
| 50                   | 32   | 40                  | 40                   | 16      | 65   | G 1/4 | 31    | 65   | M10 |
| 63                   | 32   | 45                  | 45                   | 16      | 75   | G 3/8 | 38.25 | 75   | M10 |

| Piston $\varnothing$ | KK       | KV | KW | $\varnothing MM$ f8 | PL | L2    | L3 $\pm 0,5$ | L8            | RT |
|----------------------|----------|----|----|---------------------|----|-------|--------------|---------------|----|
| 32                   | M10x1,25 | 16 | 5  | 12                  | 16 | 16.25 | 4.5          | 94 $\pm 0,4$  | M6 |
| 40                   | M12x1,25 | 18 | 6  | 16                  | 20 | 18.25 | 4.5          | 105 $\pm 0,7$ | M6 |
| 50                   | M16x1,5  | 24 | 8  | 20                  | 19 | 25    | 4.5          | 106 $\pm 0,7$ | M8 |
| 63                   | M16x1,5  | 24 | 8  | 20                  | 24 | 25    | 4.5          | 121 $\pm 0,8$ | M8 |

| Piston $\varnothing$ | SW  | TG             | VA -1 | VD | WH           | ZJ  | MK   | SW2 |
|----------------------|-----|----------------|-------|----|--------------|-----|------|-----|
| 32                   | 10  | 32,5 $\pm 0,5$ | 4     | 5  | 26 $\pm 1,4$ | 120 | 0.75 | 10  |
| 40                   | 13  | 38 $\pm 0,5$   | 4     | 5  | 30 $\pm 1,4$ | 135 | 1.5  | 13  |
| 50                   | 16* | 46,5 $\pm 0,6$ | 4     | 5  | 37 $\pm 1,4$ | 143 | 2    | 16  |
| 63                   | 16* | 56,5 $\pm 0,7$ | 4     | 5  | 37 $\pm 1,8$ | 158 | 2    | 16  |

\* not according to ISO 15552

# Tie rod cylinder ISO 1552, Series TRB

R481602030

series TRB

2024-04-26

## Cushioning diagram

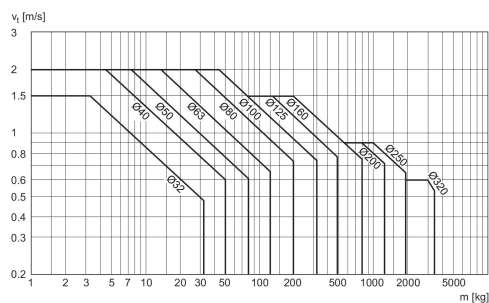

$v_1$  = Piston velocity [m/s]  $m$  = Cushionable mass [kg]

# Tie rod cylinder ISO 1552, Series TRB

series TRB

R481602030

2024-04-26

