

5/2-directional valve, Series 581, size 3

5813231000

581, size 3

2023-12-18

ISO 5599-1, series 581, size 3

Qn = 1400 l/min

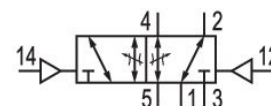

Technical data

Industry

Industrial

Activation

Pneumatically

Switching principle

5/2, double solenoid

Connection type

Plate connection

Nominal flow Qn

4800 l/min

Compressed air connection output

Base plate ISO 5599-1

Min. working pressure

-0.95 bar

Max. working pressure

16 bar

Sealing principle

Soft seal

Standards

ISO 5599-1

Valve type

Spool valve

Version

ISO 3

Throttle

with throttle

Can be assembled into blocks

Can be assembled into blocks

Blocking principle

Single base plate principle

Min. control pressure

1.5 bar

Max. control pressure

16 bar

Min. ambient temperature

-20 °C

Max. ambient temperature

70 °C

5/2-directional valve, Series 581, size 3

581, size 3

5813231000

2023-12-18

Min. medium temperature	-20 °C
Max. medium temperature	70 °C
Medium	Compressed air
Max. particle size	50 µm
Min. oil content of compressed air	0 mg/m ³
Max. oil content of compressed air	5 mg/m ³
Compressed air connection input	Base plate ISO 5599-1
Flow conductance C	18.9 l/(s*bar)
Mounting screw	with hexagon socket
Mounting screw tightening torque	10 Nm
Weight	0.85 kg
Housing material	Aluminum
Seal material	Acrylonitrile butadiene rubber
Part No.	5813231000

Technical information

The min. control pressure must be adhered to, since otherwise faulty switching and valve failure may result!

The pressure dew point must be at least 15 °C less than ambient and medium temperature and may not exceed 3 °C.

The oil content of compressed air must remain constant during the life cycle.

Use only the approved oils from AVENTICS. Further information can be found in the "Technical information" document (available in <https://www.emerson.com/en-us/support>).

Fig. 1

5/2-directional valve, Series 581, size 3

581, size 3

5813231000

2023-12-18

Hole pattern for logic modules

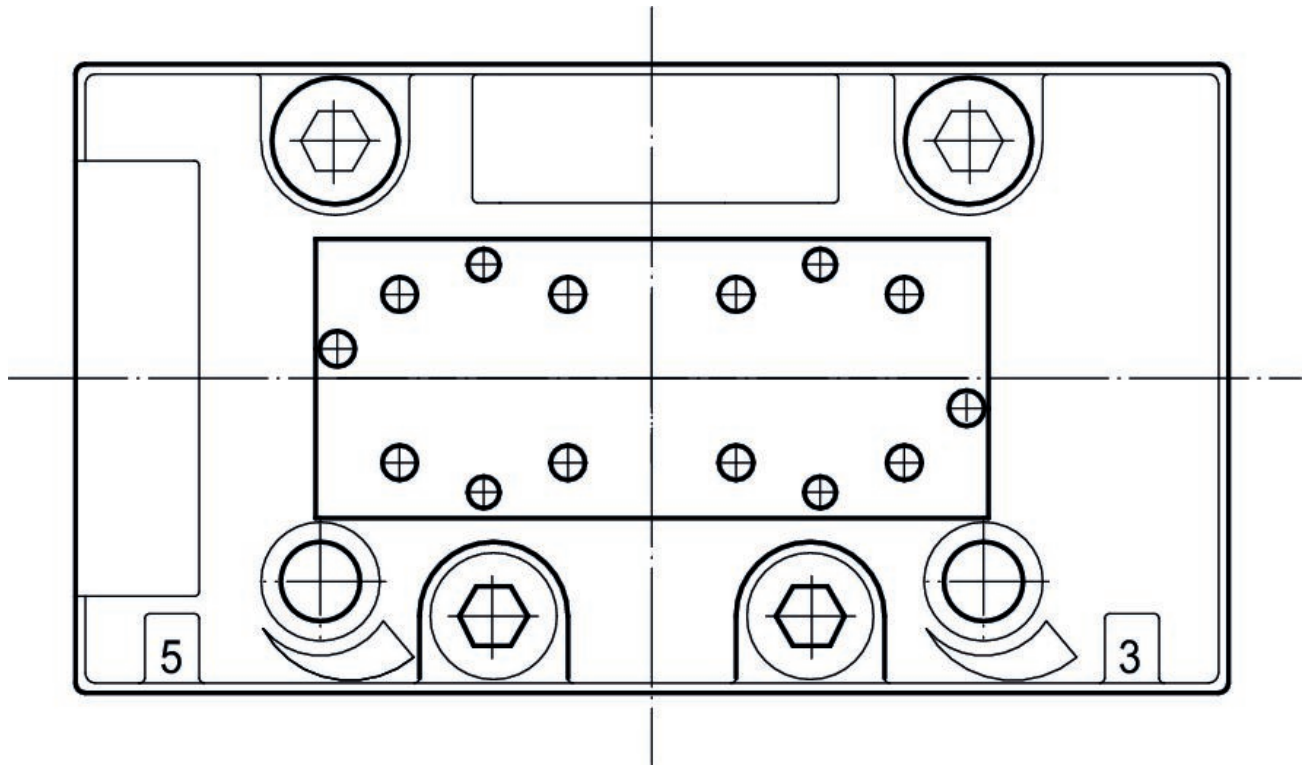

Dimensions

