

# 5/2-directional valve, Series 581, size 2

## 5812110200

ISO 5599-1, size 2, series 581

■  $Q_n = 2100 \dots 2700$  l/min

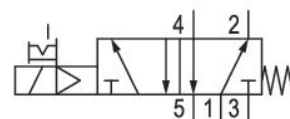

### Technical data

Industry  
Industrial

Activation  
Electrically

Nominal flow  $Q_n$   
2700 l/min

Switching principle  
5/2

Compressed air connection output  
Base plate ISO 5599-1

Working pressure min.  
3 bar

Working pressure max  
10 bar

Operational voltage AC at 50 Hz  
24 V

Voltage tolerance AC 50 Hz  
-10% / +10%

Manual override  
with detent

Electrical connection type  
Plug

Electrical connection size  
Form B, industry

Actuating control  
Single Solenoid

Sealing principle  
Soft Seal

Pilot  
Internal

Standards  
ISO 5599-1

Pilot valve width  
22 mm

Valve type  
Spool valve

<b>Blocking principle</b> Single base plate principle	<b>Max. medium temperature</b> 50 °C
<b>Connection type</b> Plate connection	<b>Medium</b> Compressed air
<b>Return</b> With spring return	<b>Max. particle size</b> 50 µm
<b>Compressed air connection input</b> Base plate ISO 5599-1	<b>Oil content of compressed air min.</b> 0 mg/m <sup>3</sup>
<b>Compressed air connection, exhaust</b> Base plate ISO 5599-1	<b>Oil content of compressed air max.</b> 5 mg/m <sup>3</sup>
<b>Compressed air connection pilot exhaust</b> M5	<b>Protection class with connection</b> IP65
<b>Holding power AC 50 Hz</b> 8 VA	<b>Duty cycle</b> 100 %
<b>Switch-on power AC 50 Hz</b> 10 VA	<b>Typ. switch-on time</b> 15 ms
<b>Flow conductance C</b> 10.8 l/(s*bar)	<b>Typ. switch-off time</b> 46 ms
<b>Frame size</b> ISO 2	<b>mounting screws</b> with hexagon socket
<b>Control pressure min.</b> 3 bar	<b>Mounting screw tightening torque</b> 3.5 Nm
<b>Control pressure max.</b> 10 bar	<b>Weight</b> 0.34 kg
<b>Min. ambient temperature</b> -15 °C	<b>Housing material</b> Polyamide fiber-glass reinforced
<b>Max. ambient temperature</b> 50 °C	<b>Seal material</b> Acrylonitrile butadiene rubber
<b>Min. medium temperature</b> -15 °C	<b>Part No.</b> 5812110200

## Technical information

The min. control pressure must be adhered to, since otherwise faulty switching and valve failure may result!

The pressure dew point must be at least 15 °C under ambient and medium temperature and may not exceed 3 °C .

The oil content of compressed air must remain constant during the life cycle.

Use only the approved oils from AVENTICS. Further information can be found in the “Technical information” document (available in <https://www.emerson.com/en-us/support>).

## Dimensions

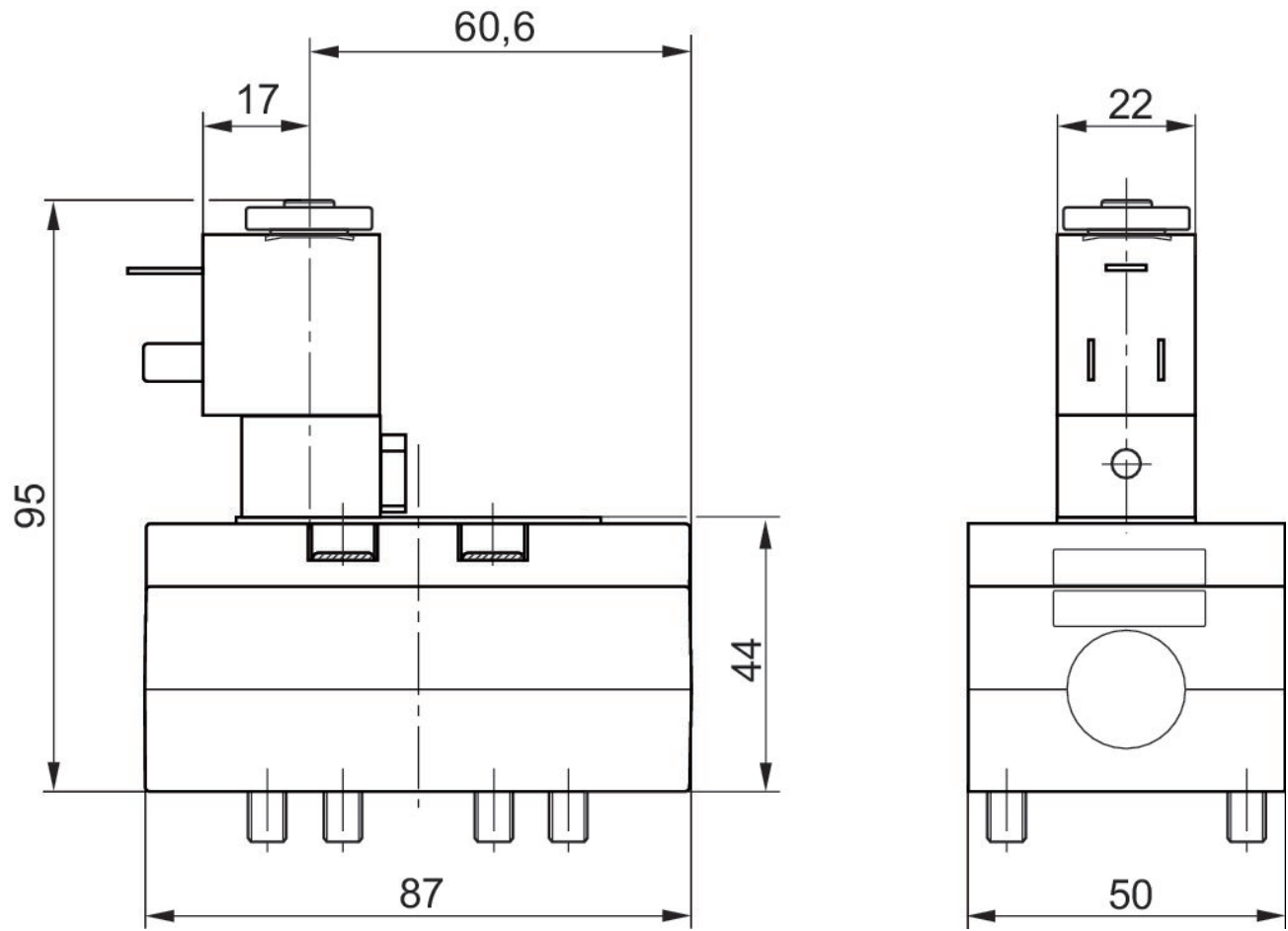

The pilot valves can be loosened and turned through 180°.