

## AVENTICS Series 740 Directional valves

The AVENTICS Series 740/840 feature directional valves with soft, abrasion-free diaphragm technology. The simple, reliable and robust design is suitable for all air qualities and ensures high repeatability and unsurpassed service life. Due to its high resilience, the corrosion-resistant polyamide housing is also suited for dusty and damp environments.



## Technical data

Industry	Industrial
Activation	Electrically
Valve type	Diaphragm poppet valve
Switching principle	5/2, double solenoid
Actuating control	Double Solenoid
Sealing principle	Soft seal
Connection type	Pipe connection
Manual override	with detent

Compressed air connection input	3/8"
Compressed air connection output	3/8"
Compressed air connection, exhaust	M14x1

Nominal flow Qn 700 l/min

Min. working pressure	1.5 bar
Max. working pressure	10 bar

Electrical connection type Plug

# 5/2-directional valve, Series 740

2023-11-27

R432016660

---

Electrical connection size	EN 175301-803, form A
Connector standard	EN 175301-803:2006
Protection class with connection	IP65
Reverse polarity protection	Protected against polarity reversal
Operational voltage	220 V AC
Operational voltage AC at 50 Hz	220 V
Voltage tolerance AC 50 Hz	-20% / +10%
Operational voltage AC at 60 Hz	220 V
Voltage tolerance AC 60 Hz	-10% / +20%

Pilot	Internal
Coil width	30 mm
Compatibility index	13 14
Holding power AC 50 Hz	3.7 VA
Switch-on power AC 50 Hz	6.4 VA

Duty cycle	100 %
Typ. switch-on time	40 ms

Blocking principle	Single base plate principle Plate principle
Can be assembled into blocks	Can be assembled into blocks
Valve plug connector	Without valve plug connector
Throttle	with throttle
Min. ambient temperature	-15 °C
Max. ambient temperature	50 °C
Min. medium temperature	-15 °C
Max. medium temperature	50 °C
Medium	Compressed air
Min. oil content of compressed air	0 mg/m <sup>3</sup>
Max. oil content of compressed air	5 mg/m <sup>3</sup>
Max. particle size	50 µm

Mounting on manifold strip	PRS strip
Weight	0.505 kg

## Material

Housing material	Polyoxymethylene
Seal material	Acrylonitrile butadiene rubber

# 5/2-directional valve, Series 740

2023-11-27

R432016660

Part No.

R432016660

## Technical information

ATEX optional: ATEX version can be produced by combining the basic valve without coil with an ATEX coil. ATEX ID: see ATEX coils catalog page.

The min. control pressure must be adhered to, since otherwise faulty switching and valve failure may result!

The pressure dew point must be at least 15 °C less than ambient and medium temperature and may not exceed 3 °C.

The oil content of compressed air must remain constant during the life cycle.

Use only the approved oils from AVENTICS. Further information can be found in the "Technical information" document (available in <https://www.emerson.com/en-us/support>).

## Dimensions in inches

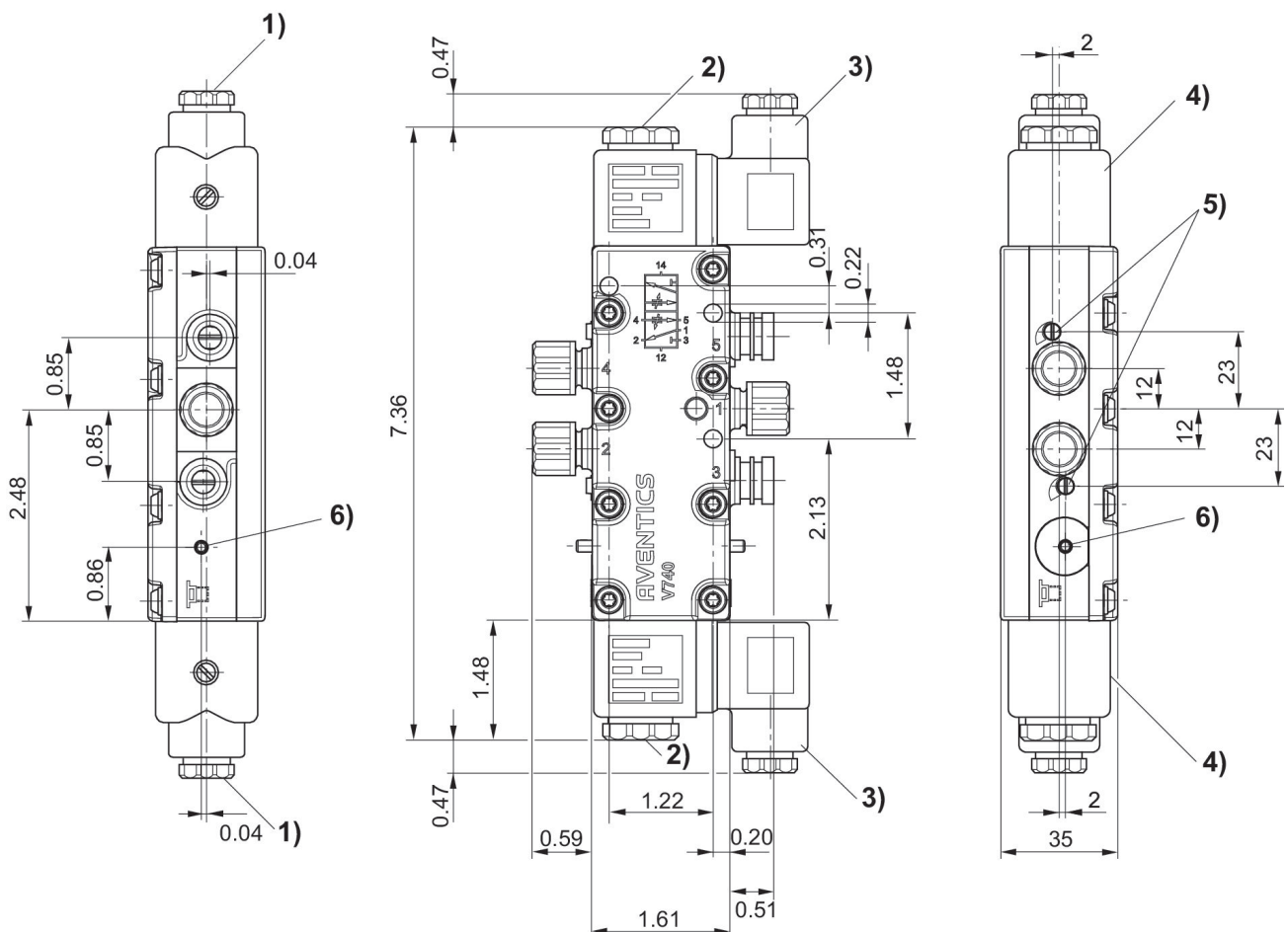

- 1) Gland fitting M16x1.5
- 2) M5 internal thread accessible under cap
- 3) Valve plug connector can be rotated at 90° intervals
- 4) Coil can be plugged at 45° intervals
- 5) Flow control screw for exhausts 5 (R) and 3 (S)
- 6) Manual override and position indicator