

## AVENTICS Series 740 Directional valves

The AVENTICS Series 740/840 feature directional valves with soft, abrasion-free diaphragm technology. The simple, reliable and robust design is suitable for all air qualities and ensures high repeatability and unsurpassed service life. Due to its high resilience, the corrosion-resistant polyamide housing is also suited for dusty and damp environments.



## Technical data

Industry	Industrial
Activation	Electrically
Valve type	Diaphragm poppet valve
Basic valve equipment	Basic valve without coil
Switching principle	5/4, exhausted center
Valve function	Exhausted Center
Actuating control	Double Solenoid
Sealing principle	Soft seal
Connection type	Pipe connection
Manual override	without detent
Compressed air connection input	3/8"
Compressed air connection output	3/8"
Compressed air connection, exhaust	M14x1
Nominal flow Qn	700 l/min
Min. working pressure	3 bar
Max. working pressure	10 bar

# 5/4-directional valve, Series 740

2024-04-30

R432002439

---

Electrical connection type	Plug
Electrical connection size	EN 175301-803, form A
Connector standard	EN 175301-803:2006
Protection class with connection	IP65
Reverse polarity protection	Protected against polarity reversal

Pilot	Internal
Coil width	30 mm
Compatibility index	14

Duty cycle	100 %
Typ. switch-on time	20 ms
Typ. switch-off time	54 ms

Blocking principle	Single base plate principle Plate principle
Can be assembled into blocks	Can be assembled into blocks
Valve plug connector	Without valve plug connector
Min. ambient temperature	-15 °C
Max. ambient temperature	50 °C
Min. medium temperature	-15 °C
Max. medium temperature	50 °C
Medium	Compressed air
Min. oil content of compressed air	0 mg/m <sup>3</sup>
Max. oil content of compressed air	5 mg/m <sup>3</sup>
Max. particle size	50 µm

Mounting on manifold strip	PRS strip
Weight	0.551 kg

## Material

Housing material	Polyoxymethylene
Seal material	Acrylonitrile butadiene rubber

Part No.	R432002439
----------	------------

## Technical information

ATEX optional: ATEX version can be produced by combining the basic valve without coil with an ATEX coil. ATEX ID: see ATEX coils catalog page.

NOTE: In order to ensure the operating function of the valve, do not fall below the minimum operating pressure of  $[[3]]$  bar!

The min. control pressure must be adhered to, since otherwise faulty switching and valve failure may result!

The pressure dew point must be at least 15 °C less than ambient and medium temperature and may not exceed 3 °C.

The oil content of compressed air must remain constant during the life cycle.

Use only the approved oils from AVENTICS. Further information can be found in the "Technical information" document (available in <https://www.emerson.com/en-us/support>).

## Dimensions in inches

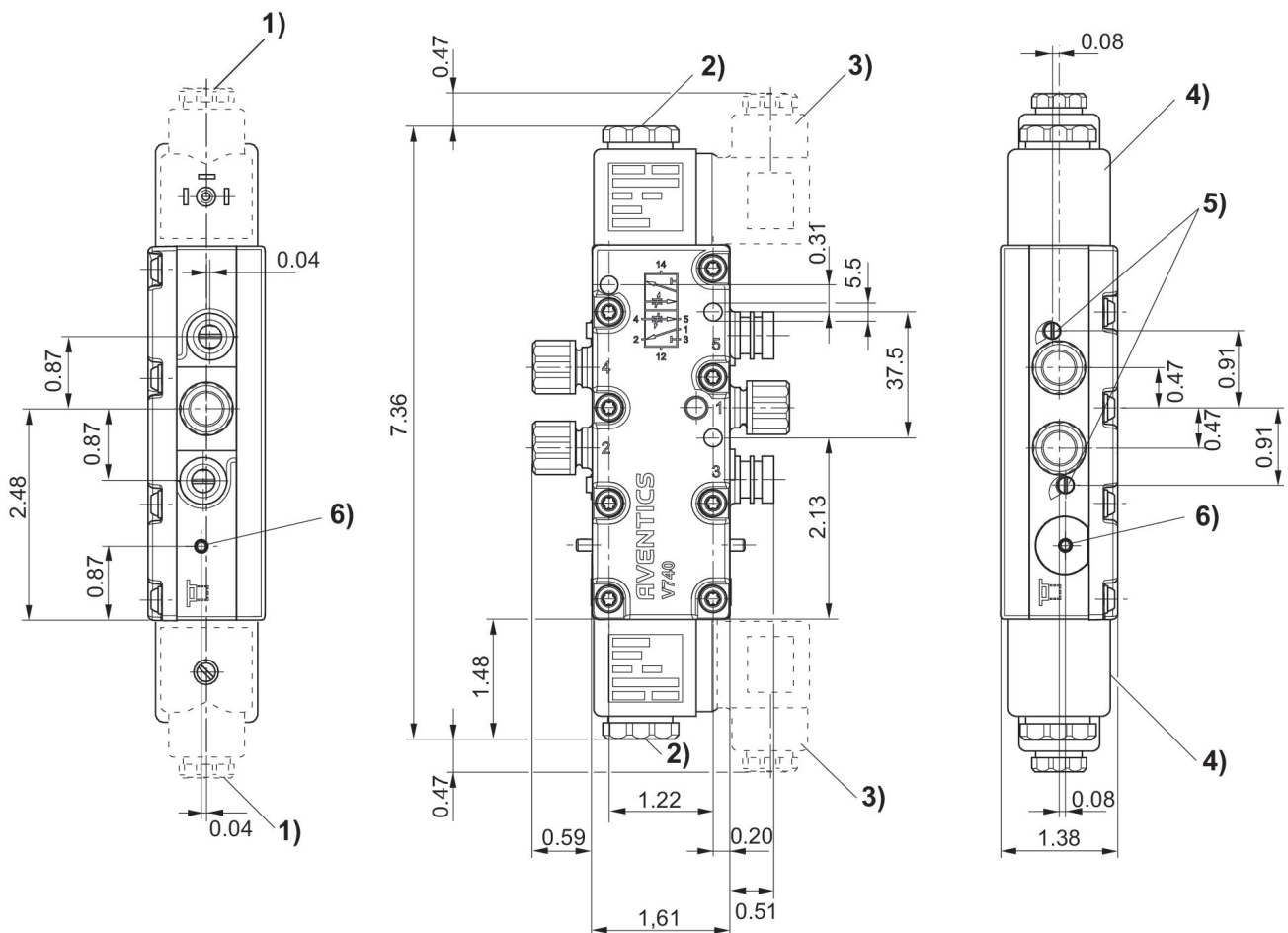

1) gland fitting M16x1,5 2) M5 internal thread accessible under cap 3) el. connector can be fixed at 90° intervals 4) coil can be mounted at 45° intervals 5) throttle screw for exhausts 5 (R) and 3 (S) 6) manual override and position indicator