

SDE5

Pressure sensor

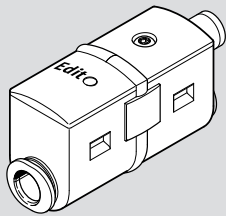

FESTO

Festo AG & Co. KG
 Rüter Straße 82
 73734 Esslingen
 Germany
 +49 711 347-0
 +49 711 347-2144
 service_international@festo.com

www.festo.com

Instructions | Operating

8110091
 2019-06f
 [8110093]



8110091

Translation of the original instructions

© 2023 all rights reserved to Festo SE & Co. KG

1 About this document

1.1 Further applicable documents

All available documents for the product → www.festo.com/pk

2 Safety

2.1 General safety instructions

- Only use the product in original status without unauthorised modifications.
- Only use the product if it is in perfect technical condition.
- Observe labelling on the product.
- Condensation, oil mist, foreign matter and other contaminants in the compressed air can damage the product. Only use media in accordance with the specifications → Technical data.
- This product can generate high frequency interference, which may make it necessary to implement interference suppression measures in residential areas.

2.2 Intended use

The SDE5 is intended for pressure monitoring of gaseous media in piping systems or terminal equipment in industry.

2.3 Training of qualified personnel

- Installation, commissioning, maintenance and disassembly should only be conducted by qualified personnel.

2.4 Area of application and approval

The information in this section, in combination with the UL marking on the product, must be observed in order to ensure compliance with the certification conditions of Underwriters Laboratories Inc. (UL) for USA and Canada. Observe the following information in English by UL:

In determining the acceptability of the combination, the following details should be examined:

- The mounting suitability shall be determined in the end-use.
- These devices shall be mounted in an enclosure having adequate strength and thickness.
- Devices should be used within its recognized ratings as specified under section RATINGS.
- Devices have to be supplied from:
 - A Class 2 power source or Class 2 transformer in accordance with UL1310 or UL1585, or
 - An isolating device such that the maximum open circuit voltage potential available to the circuit is not more than 30 Vdc and the current is limited to a value not exceeding 8 amperes measured after 1 minute of operation, or
 - A suitable isolating source in conjunction with a fuse in accordance with UL248. The fuse shall be rated max. 3.3 A and be installed in the 30 Vdc power supply to the device in order to limit the available current.

Note that, when more than one power supply or isolating device is used, connection in parallel is not permitted.

- The devices have not been investigated for field-wiring.
- The suitability should be determined in the end-use application.

UL approval information

Product category code	NRNT2 (USA) and NRNT8 (Canada)
File number	E253738

UL approval information

Considered standards	UL 508, 17th edition, C22.2 No.14-05
UL mark	

Tab. 1: UL approval information

3 Further information

- Accessories → www.festo.com/catalogue.
- Spare parts → www.festo.com/spareparts.

4 Service

Contact your regional Festo contact person if you have technical questions → www.festo.com.

5 Product overview

5.1 Configuration

5.1.1 Product design

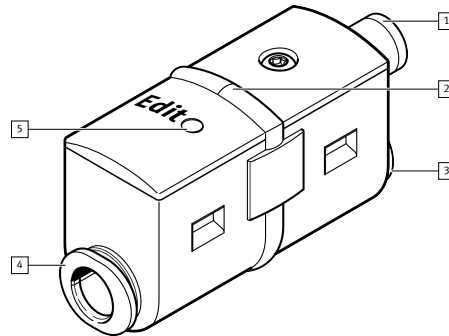

Fig. 1: Product design SDE5

- | | |
|---|--|
| 1 Electrical connection | 4 Connection 1 for compressed air or vacuum |
| 2 LED indicator (continuous transmission of the LED indicator through fibre-optic cable) | 5 Edit button (not on SDE5-...X) |
| 3 Connection 2 for compressed air or vacuum | |

MS series service unit component with pressure sensor SDE5

The pressure sensor SDE5 on the series MS service unit component is already permanently attached and pneumatically connected in the delivery status.

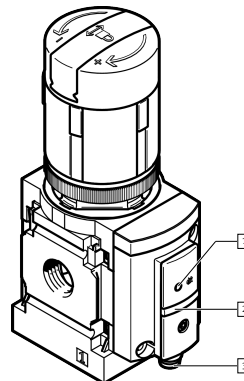

Fig. 2: SDE5 installed on the MS series service unit component



- | |
|---|
| 1 Edit button |
| 2 LED indicator (continuous transmission of the LED indicator through fibre-optic cable) |
| 3 Electrical connection |

MS series service unit component	Attached pressure sensor
MS4/6-...-AD7	SDE5-D10-O-...-P-M8
MS4/6-...-AD8	SDE5-D10-C-...-P-M8
MS4/6-...-AD9	SDE5-D10-O3-...-P-M8
MS4/6-...-AD10	SDE5-D10-C3-...-P-M8

Tab. 2: Assignment of service unit component MS and attached pressure sensor

5.1.2 LED display

LED	Meaning
LED illuminated (yellow)	SDE5-...-P/-N-... (switching output): pressure p > switching pressure
LED off	SDE5-...-P/-N-... (switching output): pressure p < switching pressure
LED flashes quickly (yellow)	Teach procedure

LED	Meaning
 LED flashes slowly (yellow)	Only SDE5-...-FP: display and setting of the switching function
 LED illuminated (green)	Only SDE5-...-V (analogue output): ready status (RUN mode)

Tab. 3: Meaning of the LED indicator

5.2 Function

5.2.1 Functional principle

The SDE5 converts pneumatic pressure values into a voltage proportional to the pressure. Depending on the design of the pressure sensor, the voltage signal is converted into a digital switching signal (SDE5-...-P-.../SDE5-...-N-...) or amplified for an analogue output (SDE5-...-NF-...-V).

The monitored pressure values record either the relative pressure or the differential pressure (SDE5-...-Z-...).

SDE5 with switching output: when the switching point is reached, the pressure sensor closes or opens a circuit.

The SDE5 is available with different switch/teach functions. The switching function is preset ex works and can only be changed for the SDE5-...-FP-...

6 Mounting

6.1 Mount SDE5 with wall bracket

NOTICE

Accumulation of condensate in the product can impair its functionality.

- Install the product in such a way that condensate from the compressed air lines cannot collect in the product.

Mounting several wall brackets

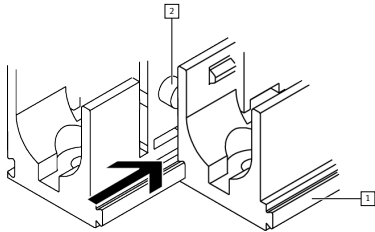

- Push the dovetail of the wall bracket into the connecting groove of the next wall bracket (push away the strap).
- Fasten first and last wall bracket with 2 screws each (∅ 4 mm). If more than 3 wall holders are being used: mount every second wall holder with 2 screws each.

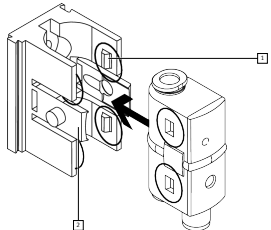

- Press SDE5 into the wall bracket.
4 snap latches engage audibly.

Individual mounting

- To make it easier to see the LED light, break out the strap of the wall bracket when mounting individually.

7 Installation

7.1 Pneumatic installation

Push-in connector

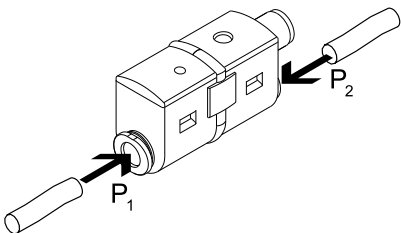

Fig. 3: Push-in connector

Push-in connector at one end

- Mount the hose to connection 1.

Push-in connector at both ends

- Check pressure conditions.
With the pressure sensor for differential pressure (SDE5-...-Z-...), the higher pressure must be applied to port 1 (differential pressure = $p_1 - p_2$).
- Mount the hoses to connection 1 and 2.

7.2 Electrical installation

⚠ WARNING

Risk of injury due to electric shock.

- For the electric power supply, use only PELV circuits that ensure a reliable electric disconnection from the mains network.
- Observe IEC 60204-1/EN 60204-1.

- Use signal lines that are shorter than 30 m.
- Configure binary outputs according to the wiring → Tab. 4 Pin allocation.
– Tightening torque for the union nut at the plug connector: max. 0.3 Nm

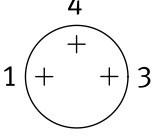
Pin	Wire colour ¹⁾	Allocation	Plug
1	Brown (BN)	Operating voltage +24 V DC	
4	Black (BK)	Switching output A (Out A) or analogue output	
3	Blue (BU)	0 V	

1) When using the connecting cable as per Accessories.

Tab. 4: Pin allocation

Circuit diagrams

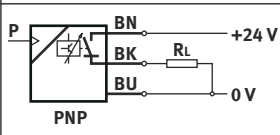
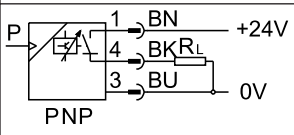
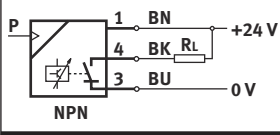
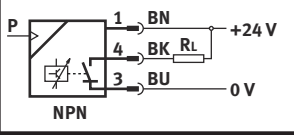
Cable connection	Plug connection
SDE5-...-P-...-K 	SDE5-...-P-...-M8 
SDE5-...-N-...-K 	SDE5-...-N-...-M8 

Tab. 5: Circuit diagrams for switching output

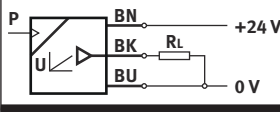
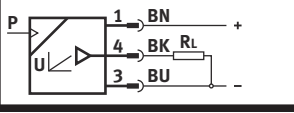
Cable connection	Plug connection
SDE5-...-V-...-K 	SDE5-...-V-...-M8 

Tab. 6: Circuit diagrams analogue output

8 Commissioning

NOTICE

Voltage interruption during the storage process will make the product unusable.

After teaching, the values are written to the internal memory. If the save process is aborted due to power interruption, the transfer process to the memory cannot be completely carried out and the device becomes unusable.

- Ensure power supply for at least 10 seconds after teaching.

→ Fig. 4 shows an overview of the possible settings and displays. The activities are described in the subsequent sections.

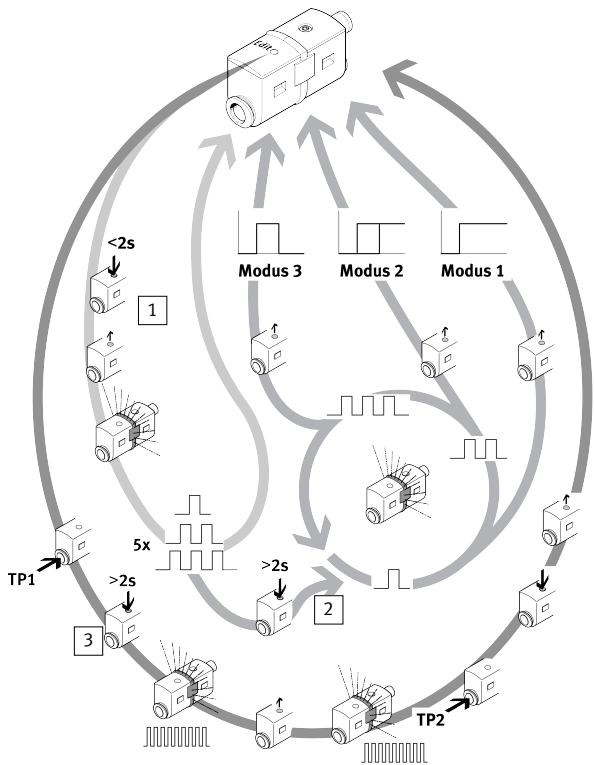

Fig. 4: Commissioning

- 1 Mode display
- 2 Mode selection
- 3 Switching pressure setting

Legend item	Description
Mode display	Display of the set mode (only with ...-FP)
Mode selection	Selection of modes 1 to 3 (only with ...-FP)
Switching pressure setting	Teaching the switching pressures TP1 and TP2 (mode 0 ... 3)

Tab. 7: Legend Commissioning variants

8.1 SDE5-...-X without Edit button

The SDE5-...-X without Edit button is preset ex works with fixed switching points and requires no additional commissioning.

8.2 SDE5-...-NF-...-V with analogue output

- Switch on the operating voltage.
 - LED lights green.
- Apply switching pressure to SDE5.
 - The pressure measuring range is applied → Tab. 8 Analogue signal dependent on pressure measuring range to the analogue output as an electrical pressure proportional signal.

Sensor	Pressure measuring range	Signal range		
		0 V	5 V	10 V
SDE5-V1	bar	0	-0.5	-1
	MPa	0	-0.05	-0.1
SDE5-B2	bar	-1	0	1
	MPa	-0.1	0	0.1
SDE5-D2	bar	0	1	2
	MPa	0	0.1	0.2
SDE5-D6	bar	0	3	6
	MPa	0	0.3	0.6
SDE5-D10	bar	0	5	10
	MPa	0	0.5	1

Tab. 8: Analogue signal dependent on pressure measuring range

8.3 SDE5-...-O/C-...-P/N with switching output

Set the switching pressure SP with one teach pressure

- Switch on the operating voltage.
- Apply teach pressure to SDE5.
- Press and hold the Edit button for at least 2 seconds.
 - LED flashes.
- Release the Edit button.
 - Teach pressure is stored as switching point SP.
- Ensure power supply for at least 10 seconds.
- Test in test run whether SDE5 switches as desired. The LED lights when the switching signal is output.

Mode	NO (normally open)	NC (normally closed)
Mode 0: Threshold value comparator (threshold value with fixed hysteresis Hy)		

Tab. 9: Signal curve over the applied pressure p with switching points

8.4 SDE5-...-O1/O2/O3/C1/C2/C3-...-P/N with switching output

Set the switching pressure SP with two teach pressures TP1/TP2

- Switch on the operating voltage.
- Apply teach pressure TP1 to SDE5.
- Press and hold the Edit button for at least 2 seconds.
 - LED flashes.
- Release the Edit button.
 - Teach pressure TP1 is stored.
- Apply teach pressure TP2 to SDE5.
- Press the Edit button until the LED stops flashing.
- Release the Edit button.
 - Teach point TP2 is stored.
- Ensure power supply for at least 10 seconds.
- Test in test run whether SDE5 switches as desired. The LED lights when the switching signal is output.

Mode	NO (normally open) ¹⁾	NC (normally closed) ²⁾
Mode 1: - Threshold value comparator (threshold value with fixed hysteresis Hy) - Switching pressure SP = (TP1 1/2 + TP2) - Preset mode for output function FP		
Mode 2: Hysteresis comparator (threshold value with variable hysteresis Hy)		
Mode 3: Window comparator with fixed hysteresis Hy		

1) Default settings: TP1 = 20 % FS; TP2 = 80 % FS

2) Default settings: TP1 = 80 % FS; TP2 = 20 % FS

Tab. 10: Signal curve over the applied pressure p with switching points

8.5 SDE5-...-FP-...-P/N with switching output

Set mode

- Switch on the operating voltage.
- Briefly press Edit button (< 2 seconds).
 - LED shows the current mode → Tab. 11 Mode display.
- Press and hold the Edit button until the desired mode is displayed.
- To save the mode, release the Edit button.
- Ensure power supply for at least 10 seconds.
- Set switching pressure SP.

	Mode 1	Mode 2	Mode 3
LED flash sequence for set mode ¹⁾			
LED flash sequence at change of mode			

1) The currently set mode is displayed 5 times in succession. The SDE5 then switches to RUN mode.

Tab. 11: Mode display

Set the switching pressure with two teach pressures TP1/TP2

- Relationship between teach pressure, switching pressure and hysteresis → Tab. 10 Signal curve over the applied pressure p with switching points.

- When setting the switching points, note the following relationship between the teach points:
 - TP1 < TP2: programming as N/O contact
 - TP1 > (TP2 + 2 % FS): Programming as N/C contact
- Apply teach pressure TP1 to SDE5.

3. Press and hold the Edit button for at least 2 seconds.
 - ↳ LED flashes.
4. Release the Edit button.
 - ↳ Teach pressure TP1 is stored.
5. Apply teach pressure TP2 to SDE5.
6. Press the Edit button until the LED stops flashing.
7. Release the Edit button.
 - ↳ Teach pressure TP2 is stored.
8. Ensure power supply for at least 10 seconds.
9. Test in test run whether SDE5 switches as desired. The LED lights when the switching signal is output.

9 Operation and use

NOTICE

Property damage due to high temperatures.

Extreme pneumatic conditions (high cycle rate with high pressure amplitude) can heat the product above 80 °C.

- Select the operating conditions (in particular the ambient temperature, pressure amplitude, cycle rate, current consumption) such that the product does not heat up above 80 °C.

- Switch on the operating voltage.
 - ↳ The SDE5 is in RUN mode (basic status).

10 Service

1. Turn off energy source and compressed air.
2. Clean sensor with non-abrasive cleaning agents.

11 Fault clearance

Fault description	Cause	Remedy
No LED indicator	Pressure p < switching pressure (SP)	regular operating status → 5.1.2 LED display
	No operating voltage or impermissible operating voltage	Switch on the operating voltage. / maintain operating voltage range.
	Connections are reversed (reverse polarity)	Wire the SDE5 in accordance with the pin allocation → Tab. 4 Pin allocation.
	Pressure failure	Eliminate pressure failure.
LED indicator or switching output does not react in accordance with the settings	SDE5 defective	Replace device.
	Short circuit or overload at the output	Rectify short circuit/overload.
	Incorrect switching point taught	Repeat teach procedure.
	SDE5 defective	Replace device.

Tab. 12

12 Disassembly

1. Turn off energy source and compressed air.
2. Disconnect pneumatic and electrical connections.
3. Slide the screwdriver into the groove of the wall bracket and swivel out the SDE5.

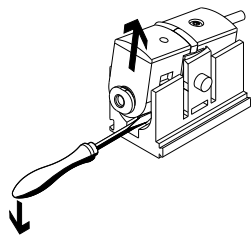

13 Disposal

ENVIRONMENT

Send the packaging and product for environmentally sound recycling in accordance with the current regulations → www.festo.com/sp.

14 Technical data

SDE5	-V1	-B2	-D2	-D6	-D10
General					
Approval	RCM, c UL us – Recognised (OL)				
CE marking (declaration of conformity → www.festo.com/sp)	In accordance with EU EMC Directive In accordance with EU RoHS directive				
Note on materials	RoHS-compliant				
Input signal/measuring element					
Pressure measuring range [bar]	0 ... -1	-1 ... 1	0 ... 2	0 ... 6	0 ... 10
Pressure measuring range [MPa]	0 ... -0.1	-0.1 ... 0.1	0 ... 0.2	0 ... 0.6	0 ... 1
Max. overload pressure [bar]	5	5	6	15	15

SDE5	-V1	-B2	-D2	-D6	-D10
Max. overload pressure [MPa]	0.5	0.5	0.6	1.5	1.5
Operating medium	Compressed air to ISO 8573-1:2010 [7:4:4]				
Note on the operating medium	Lubricated operation possible				
Temperature of medium [°C]	0 ... +50				
Ambient temperature [°C]	0 ... +50				
Output, general					
Repetition accuracy [% FS]	±0.3 (momentary)				
Temperature coefficient [% FS/K]	max. ±0.05				
Short circuit current rating	Yes				
Overload protection	Present				
Switching output					
Accuracy [% FS]	Max. ±0.5				
Switching time (On/Off) ¹⁾ [ms]	2 (typical) / 4 (max.)				
Max. output current [mA]	100				
Capacitive load (maximum DC) [nF]	100				
Voltage drop [V]	Max. 1.8				
Inductive protective circuit	adapted to MZ, MY, ME coils				
Analogue output					
Output characteristic [V]	0 ... 10				
Accuracy [% FS]	±3 (room temperature: 20 ... 25 °C) max. ±4 (0 ... 50 °C)				
Rise time [ms]	5 (typical) with resistive load				
Min. load resistance [kΩ]	2				
Electronics					
Operating voltage range [V DC]	15 ... 30				
No-load supply current [mA]	Max. 34				
Ready-state delay [ms]	≤20				
Reverse polarity protection	For all electrical connections				
Electromechanics					
Max. cable length [m]	30				
Information on materials - cable sheath	PUR				
Information on materials – plug housing	Brass (nickel-plated, chrome-plated)				
Cable diameter [mm]	2.9				
Nominal conductor cross section [mm ²]	0.14				
Mechanics					
Mounting position	Any, preferably vertical ²⁾				
Information on materials - housing/keypad	Polyamide (POM) reinforced				
Information on materials – plug housing	PA				
Display/operation					
Threshold value setting range:					
Switching pressure [% FS]	0 ... 100 (recommended working range: 1 ... 99)				
Hysteresis (mode 2) [% FS]	0 ... 100 (recommended working range: 1 ... 99)				
Hysteresis (mode 0, 1, 3) [% FS]	2 (permanently set)				
Immission/emission					
Storage temperature [°C]	-20 ... +80				
Degree of protection	IP40				
Protection class	III				
Shock resistance	30 g acceleration with 11 ms duration (half-sine)				
Vibration resistance	0.35 mm travel, 5 g acceleration at 10 ... 150 Hz				
Corrosion resistance class CRC	2				

1) Switching times are not applicable with activated additional function ...TF (filter function).

2) Condensation must not collect in the pressure measuring cell.

Tab. 13: Technical data