

SFAH

Flow sensor

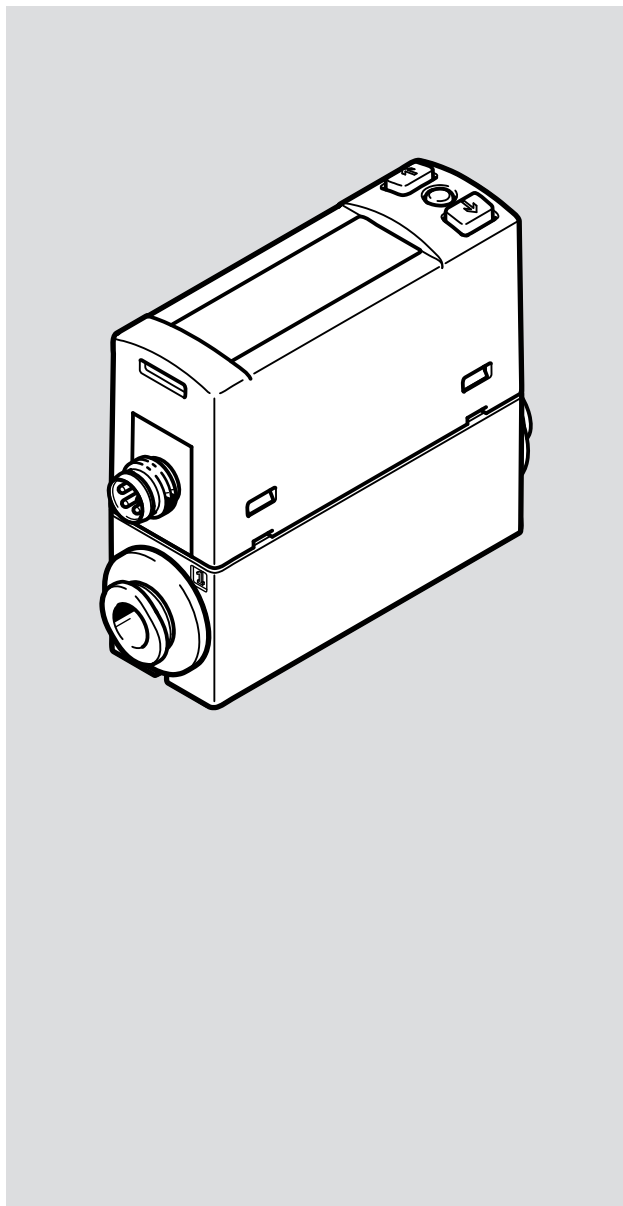

FESTO

Operating instruc-
tion



8185054

8185054
2023-08c
[8185056]

Translation of the original instructions

IO-Link is a registered trademark of its respective trademark holder in certain countries.

Table of contents

1	Applicable documents	5
2	Safety	5
2.1	Safety instructions.....	5
2.2	Intended use.....	5
2.3	Training of qualified personnel.....	5
2.4	UL/CSA certification.....	5
3	Additional information	6
4	Product overview	6
4.1	Structure.....	6
4.1.1	Product design.....	6
4.1.2	Display components.....	7
4.2	Function.....	10
4.2.1	Functional principle.....	10
4.2.2	Operating statuses.....	10
4.2.3	Switching outputs.....	11
4.2.4	Standard switching condition for volume values - 'REF'/'Cond'.....	13
4.2.5	Filter.....	14
4.2.6	Analogue output.....	14
4.2.7	Minimum value and maximum value.....	15
4.2.8	Replicate parameter function.....	15
4.2.9	Offset adjustment.....	15
5	Assembly	16
5.1	Mounting the sensor on the H-rail.....	16
5.2	Mounting the sensor with wall mounting.....	17
5.3	Mounting sensor on plate.....	17
5.4	Mounting sensor on plate at the side.....	18
5.5	Mounting sensor with front panel mounting kit.....	18
6	Installation	19
6.1	Pneumatic installation.....	19
6.1.1	Infeed situation.....	19
6.2	Electrical installation.....	20
7	Commissioning	21
7.1	Switching on the sensor in RUN mode.....	21
7.2	Displaying parameters in SHOW mode.....	21
7.3	Configuring the sensor in EDIT mode.....	23
7.3.1	Entering security code.....	23
7.3.2	Configuring the switching output.....	24
7.3.3	Changing device settings.....	25
7.3.4	Setting the volume pulse output.....	25
7.3.5	Setting the analogue output.....	25

	7.3.6	Replicating parameters.....	26
	7.3.7	Performing offset adjustment.....	26
	7.4	Teaching switching points in TEACH mode.....	27
8		IO-Link interface description.....	27
	8.1	General information, IO-Link.....	27
	8.2	Identification parameters.....	29
	8.3	IO-Link default parameters.....	29
	8.4	IO-Link system commands.....	30
	8.5	Smart sensor profile parameters.....	31
	8.6	Device-specific parameters.....	33
	8.7	IO-Link teach-in.....	36
	8.8	Block parameterisation.....	37
	8.9	Process data IN.....	38
	8.10	Conversion factors.....	39
	8.10.1	Conversion factors for process data variable, process data variable min, process data variable max, and setpoint values SP1, SP2.....	39
	8.10.2	Conversion factors for hysteresis, switching point d.SP and max. signal delta (S.obS).....	40
	8.10.3	Conversion factors for volume units and mass units.....	41
	8.10.4	Scaling factors for gases.....	42
	8.11	IO-Link diagnostics.....	42
9		Operation.....	43
	9.1	Switching on the Sensor.....	43
	9.2	Restoring factory settings (Restore).....	43
10		Malfunctions.....	43
	10.1	Fault clearance.....	43
	10.2	Error messages.....	44
11		Removal.....	45
12		Technical data.....	45
	12.1	Technical data, general.....	45
	12.2	Technical data for UL/CSA certification.....	51
	12.3	Examples for calculating the maximum error of the display.....	51

1 Applicable documents



All available documents for the product → www.festo.com/sp.

Document	Content
IO-Link IODD	Device description file

Tab. 1: Applicable documents

2 Safety

2.1 Safety instructions

- Only use the product in its original condition without unauthorised modifications.
- Only use the product if it is in perfect technical condition.
- Observe labelling on the product.
- Only use media in accordance with the specifications → Technical data.
- The product may generate high frequency interference, which may require interference suppression measures in residential areas.

2.2 Intended use

The flow sensor monitors the flow rate of gaseous media in pipe systems or terminals in industrial applications.

2.3 Training of qualified personnel

Work on the product may only be carried out by qualified personnel who can evaluate the work and detect dangers. The qualified personnel have skills and experience in dealing with electropneumatic (open-loop) control technology.

2.4 UL/CSA certification

In combination with the UL inspection mark on the product, the information in this section must also be observed in order to comply with the certification conditions of Underwriters Laboratories Inc. (UL) for USA and Canada.

UL/CSA certification information	
Product category code	QUYX, QUXX7
File number	E322346
Considered standards	UL 61010-1 CAN/CSA C22.2 No. 61010-1
UL mark	 US LISTED

Tab. 2: UL/CSA certification information

The Front panel mounting kit SAMH-FH-F can be used only for mounting SFAH behind a plate. Cabinet mounting was not evaluated by UL.

⚠ WARNING

The unit shall be supplied by a power source which fulfils the requirements on a limited-energy circuit in accordance to IEC/EN/UL/CSA 61010-1 or on a Limited Power Source (LPS) in accordance to IEC/EN/UL/CSA 60950-1 or IEC/EN/UL/CSA 62368-1 or a Class 2 circuit in accordance to NEC or CEC.

3 Additional information

- Contact the regional Festo contact if you have technical problems → www.festo.com.
- Accessories and spare parts → www.festo.com/catalogue.

4 Product overview

4.1 Structure

4.1.1 Product design

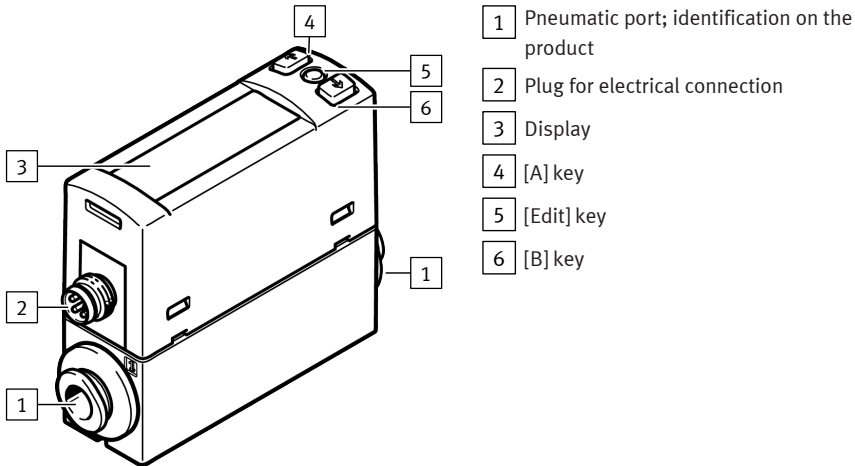

Fig. 1: Product design

4.1.2 Display components

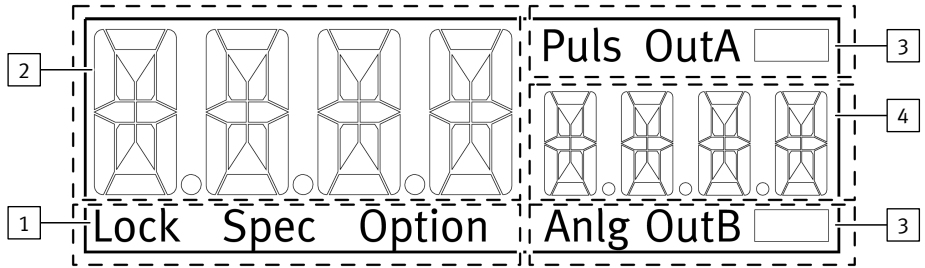

Fig. 2: LCD display

- 1 Status information

2 Main display, e.g. measured value

3 Output display
- 3 Output display

4 Sub-display, e.g. unit

Symbols on the display

Example for LCD display	Description
Output display	
'OutA'	Switching output OutA selected/activated, flashes with active IO-Link
'OutA' 	Switching output OutA set
'OutB'	Switching output OutB selected/activated
'OutB' 	Switching output OutB set
'Pulse'	Analogue output for volume pulse and mass pulse selected
'Anlg'	Analogue output for flow rate selected/activated
Status information	
'Lock'	Security code activated
'Spec'	Special menu selected
'Option'	Parameters that influence the measured value display have been changed from the factory setting: reference condition (standard) or gas

Tab. 3: Output display and status information

Example for LCD display		Description
Main display	Sub-display	
Measured value indicator and unit in RUN mode		
'-0.53'	'L.Min'	Measured value indicator and unit
Menu items for the OutA and OutB switching outputs		
'Edit'	'bin'	EDIT menu for the switching outputs
'_ _'	'Fctn'	Threshold value comparator
'_ _ '	'Fctn'	Window comparator
'd_ _ '	'Fctn'	Auto difference monitor
'18.0'	'SP'	Switching point value
'1.80'	'SP.Lo'	Value of lower switching point
'6.45'	'SP.Hi'	Value of upper switching point
'0.50'	'HY'	Hysteresis value
'18'	't.obS'/'MSEC' ¹⁾	Time interval for determination of the signal change, which is used to establish the reference value.
'0.25'	'd.SP'	Threshold value for determination of the monitoring range
'N/O'	'LOGC'	Switching characteristics of the switching outputs: 'NO' = N/O contact, 'NC' = N/C contact
'bLUE'	'COLR'	Display colour
Extreme values, SHOW mode only		
'1.64'	'MIN'	Minimum measured value since switching on the supply voltage or since the last reset
'8.50'	'MAX'	Maximum measured value since switching on the supply voltage or since the last reset
'20.8'	'AVER'	Average of the flow rate measurement, filter time constants
Additional settings		
'100'	'PULS'	Duration of the volume pulse or mass pulse at the output
Analogue output		
'Edit'	'ANLG'	EDIT menu for the analogue output
'0...10'	'Out'/'V' ¹⁾	Output function of the analogue output

Example for LCD display		Description
Main display	Sub-display	
'100'	'In.Hi'/'%' ¹⁾	Scaling of the analogue output to the end value of the flow measuring range in percent of FS
'-100'	'In.Lo'/'%' ¹⁾	Scaling of the analogue output to the start value of the flow measuring range in percent of FS
Menu for Spec device settings		
'Edit'	'Menu'	EDIT menu for additional settings
'16'	'Filt'/'MSEC' ¹⁾	Value of the filter time constant for the measurement signal
'L.Min'	'FLOW'/'Unit'	Display unit for flow rate measurement
'0°C'	'REF'/'Cond' ¹⁾	Reference standard for gas volume
'Air'	'GAS'	Selection of the operating medium
'1->2'	'FLOW'/'Path' ¹⁾	Selection of the flow direction from port 1 to port 2 or vice versa, only with bidirectional calibrated product variant
'ON'	'Z.Adj'	Offset adjustment for display, switching output and analogue output
'Unit'	'Sub.d'	Settings of the sub-display in RUN mode: selected unit or switching point of OutA or bar graph or gas or flow direction
'40'	'Eco'/'SEC' ¹⁾	Economy mode: Time period after which the display backlight is switched off
'PNP'	'bin'/'Out' ¹⁾	Switchover of the switching outputs between PNP and NPN
'Flow'	'bin'/'Pin4' ¹⁾	Shift of binary switching output or pulse output. Pin 4 with M8 variant, pin 2 with L1 variant
'bin'	'FLOW'/'Pin2' ¹⁾	Switching binary switching output or analogue output at pin 2 with M8 variant, pin 3 with L1 variant
'OFF'	'Code'	Activation and specification of the security code
'OFF'	'MASt'	Activation of the IO-Link master function for replication of parameters

1) flashing alternately

Tab. 4: Example for LCD display

4.2 Function

4.2.1 Functional principle

The sensor measures the flow rate (standard volume flow rate, mass flow rate) by a thermal process. The flow rates are measured by a micromechanical sensor element with a downstream electronic evaluation unit. The sensor is connected to higher-level systems via switching outputs, a volume switching pulse, an analogue output or an IO-Link interface. Depending on their configuration, the switching outputs monitor a threshold value, an analogue input or a signal change. The outputs can be set as PNP or NPN and normally open (NO) or normally closed (NC). Process values can be read out and parameters can be changed and transmitted to additional devices through the IO-Link interface. A volume signal/mass signal can be calculated and output via a pulse output along with a cumulative measured value via IO-Link by integration of the flow rate.

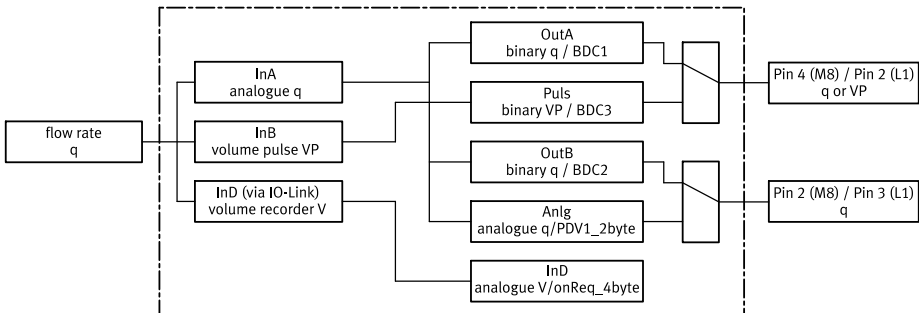

Fig. 3: SFAH signal structure

4.2.2 Operating statuses

Operating status	Function
RUN mode	<ul style="list-style-type: none"> – Basic status after the operating voltage is applied – Display of the current measured value. – Display of the selected inputs and outputs. – Switching between the flow rate and volume/mass measured variables.
SHOW mode	<ul style="list-style-type: none"> – Display of the current settings of the switching outputs and analogue output. – Display and reset of minimum and maximum values. – Display of the average flow rate measurement.
EDIT mode	<ul style="list-style-type: none"> – Setting parameters.
TEACH mode	<ul style="list-style-type: none"> – Acceptance of the current measured value to specify switching points.

Tab. 5: SFAH operating statuses

4.2.3 Switching outputs

4.2.3.1 Switching functions

Threshold value comparator

Function	Normally open contact (N/O)	Normally closed contact (N/C)
Switching function: – 1 switching point (SP)		
TEACH mode: – 2 teach points (TP1, TP2) – $SP = \frac{1}{2}(TP1 + TP2)$		

Tab. 6: Threshold value comparator

Window comparator

Function	Normally open contact (N/O)	Normally closed contact (N/C)
Switching function: – 2 switching points (SP.Lo, SP.Hi)		
TEACH mode: ¹⁾ – 2 teach points (TP1, TP2) – $TP1 = SP.Lo, TP2 = SP.Hi$		

1) SP.Lo = lower value, SP.Hi = higher value, independent of the teach sequence

Tab. 7: Window comparator

Auto difference monitoring d_I_

Auto difference monitoring can be used to monitor the consistency of a signal value. If the applied signal is consistent within the range between 'SP.Lo' and 'SP.Hi', the reference value q_{Ref} is set automatically. Consistent means that over the 't.obS' period the maximum signal change 'S.obS' is less than 0.2% FS. This results in a switching operation at the output and signals the start of the signal monitoring. The signal is stable if it remains in the 'd.SP' monitoring range around q_{Ref} . If it leaves the monitoring range the output switches back.

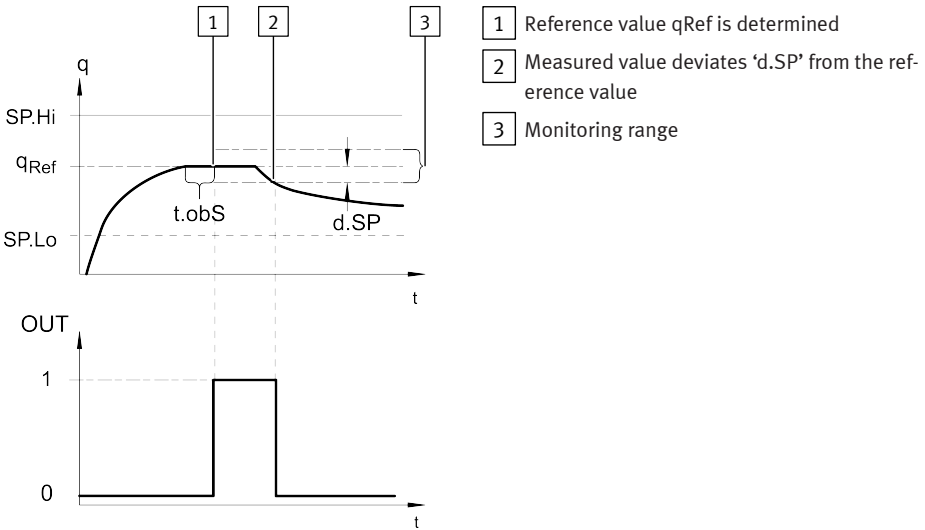

Fig. 4: Auto difference monitor

The ‘SP.Lo’, ‘SP.Hi’, ‘t.obS’ and ‘d.SP’ parameters can be freely configured. The higher ‘t.obS’ is set the greater the required signal stability in order to define the reference value q_{Ref} . The limit value for a maximum signal change ‘S.obS’ can only be adjusted via IO-Link.

Function	Normally open contact (N/O)	Normally closed contact (N/C)
Switching function: – 2 switching points (SP.Lo, SP.Hi) for setting the valid working range – 1 switching point (d.SP) for determining the monitoring range		
TEACH mode: ¹⁾ – 2 teach points (TP1, TP2) – TP1 = SP.Lo, TP2 = SP.Hi		

1) SP.Lo = lower signal value, SP.Hi = higher signal value, independent of the teach sequence

Tab. 8: Window comparator: auto difference monitoring

4.2.3.2 Colour change of the display

A red colour change can be set in the display for the switching outputs OutA and OutB depending on the switching status. The colour change enables the system status to be identified from a greater distance. Depending on the setting the colour change reacts both to OutA and to OutB.

Parameter	Meaning
'bLUE'	The display is always blue; the colour change function is disabled.
'R.On'	The display is red if the switching output is set (high = 1). The display is blue if the switching output is not set (low = 0).
'R.OFF'	The display is red if the switching output is not set (low = 0). The display is blue if the switching output is set (high = 1).

Tab. 9: Colour change of the display

4.2.3.3 Volume pulse/mass pulse

A threshold value SP can be set for the volume and/or the mass with the cumulative volume measurement/mass measurement. If the configured threshold value is reached, the sensor sends a switching pulse at the pulse output (→ Fig. 3) for an adjustable time. The volume measurement/mass measurement is restarted at every switching pulse.

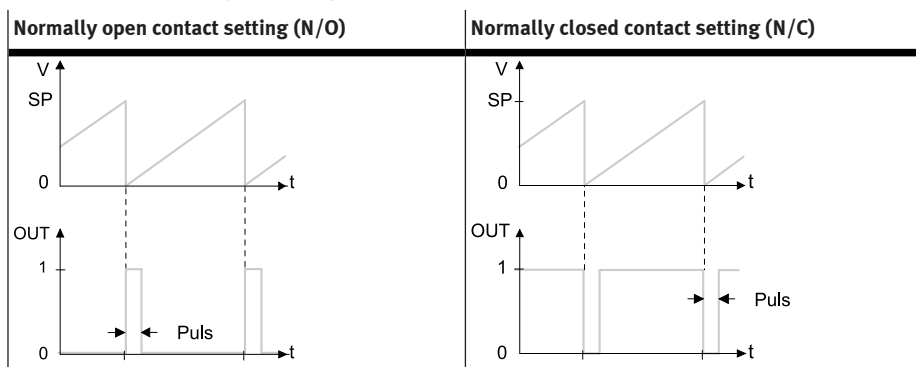

Tab. 10: Volume pulse/mass pulse with cumulative volume measurement/mass measurement

4.2.4 Standard switching condition for volume values - 'REF'/'Cond'

The represented flow rate units can be related to different standard conditions. It is possible to switch between the following standard conditions. The corresponding standard is defined by selection of the reference temperature in the menu guiding on the display.

'REF'/'Cond'		Off	15 °C	20 °C
Standard		DIN 1343	ISO 2533	ISO 6358
Air pressure (absolute)	[bar]	1.01325	1.01325	1
	[kPa]	101.325	101.325	100
Temperature	[°C]	0	15	20
Humidity	[%]	0	0	65

'REF'/'Cond'	Off	15 °C	20 °C
Status information (option)	Light off	Light on	Light on
Correction factor, measurement range end value	1	1.055	1.087

Tab. 11: Standard condition for volume values

The sensor is factory calibrated to the physical standard conditions in accordance with DIN 1343. If a different standard from DIN 1343 is selected, this changes the specified measurement range ($\pm 100\%$ FS) by the defined correction factor. This change is shown on the display by 'Option'. Only the display on the sensor monitor is adjusted when the reference standard is switched. If necessary, the effect on the nominal measurement range of the specific sensor must also be considered when evaluating the analogue output.

4.2.5 Filter

The low-pass filter 'Filt' smooths the flow rate input signal. It also changes the rise time and the fall time. Filtering affects all outputs. The filter time corresponds to the time constant T of a low-pass filter. In the SHOW mode a smoothed average 'AVER' of the flow rate measurement can be displayed.

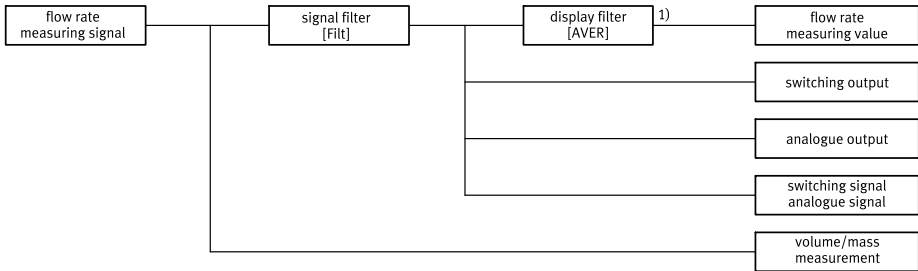

Fig. 5: Example: scaling of the analogue signal at the current output

1) The display filter is only active while 'AVER' is selected in SHOW mode.

4.2.6 Analogue output

Analogue signal

The analogue output can be configured either as voltage output 0 ... 10 V or 1 ... 5 V or as current output 4 ... 20 mA. The voltage output is factory-set to 0 ... 10 V.

Scaling of the analogue signal

With the bidirectional sensor variants, the analogue output signal is 0 ... 10 V, 1 ... 5 V or 4 ... 20 mA the complete sensing range ($-100 \dots 100\%$ FS) and with the unidirectional sensor variants the analogue output signal is assigned to the positive sensing range (0 ... 100% FS). If only a part of the sensing range is to be used, the analogue value output can be scaled to this partial sensing range with the 'In.Lo' and 'In.Hi' parameters.

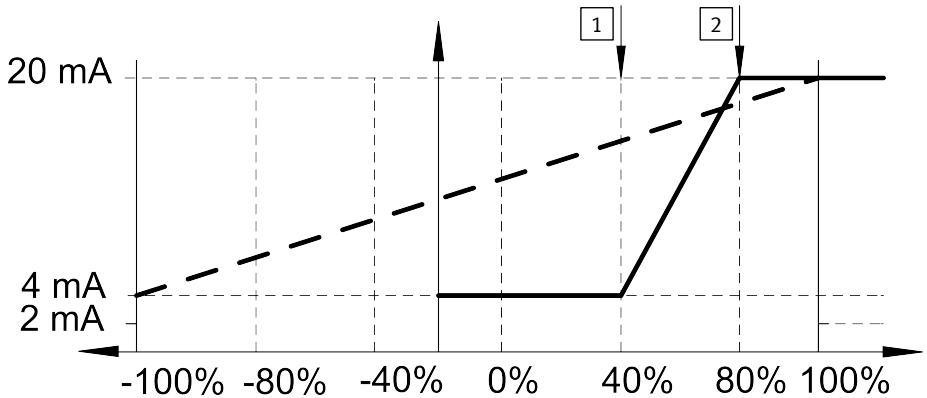

Fig. 6: Scaling the analogue signal at the current output

- 1** Starting point of the scaled sensing range (In.Lo) **2** End point of the scaled sensing range (In.Hi)

4.2.7 Minimum value and maximum value

The minimum values and the maximum values for the flow rate measurement are displayed and reset in the SHOW mode.

i

Switching off the operating voltage resets the minimum and maximum values.

4.2.8 Replicate parameter function

This function enables all settings that have been carried out on one sensor (master) to be transferred to other identical sensors (device).

Parameters are transferred with the IO-Link functions. The configured sensor is set to a master mode and can then send its parameters to an identical device sensor (identical device ID).

4.2.9 Offset adjustment

An offset adjustment can be made for the zero point. The offset adjustment influences the display and all outputs. The offset adjustment is only available with the zero adjust setting = 'ON'. As a result, the zero range hiding is no longer active. The zero adjust function 'Z.Adj' to 'ON' is the default setting for bidirectional sensor types. If 'Z.Adj' is set to 'ON', the offset error visible on the display can be set to zero by a zero adjust teach process. This requires the measured value in the $\pm 3\%$ FS range based on the original factory comparison for the teach process.

If the 'Z.Adj' parameter is reset to 'OFF', the stored adjustment value is no longer taken into account and the device takes the calibration values from the factory setting. The saved value is not lost and is used again if the 'Z.Adj' parameter is set to 'ON'.

5 Assembly

NOTICE

An unfavourable mounting position may impair the function of the product.

- When selecting the mounting position, make sure that condensate from the compressed air lines cannot accumulate in the sensor.



Any mounting position is possible but can have an influence on measurement precision (→ 12.1 Technical data, general).

5.1 Mounting the sensor on the H-rail

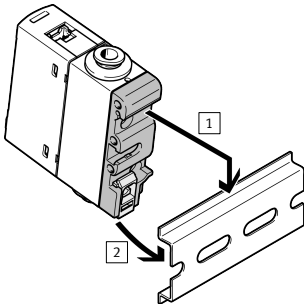

Fig. 7: H-rail mounting

1. Mount the H-rail on the sensor.
 - Tightening torque: maximum 0.5 Nm
2. Attach the H-rail mounting to the H-rail.
3. Press the H-rail mounting in the direction of the arrow until the fastening lock clicks into position.

5.2 Mounting the sensor with wall mounting

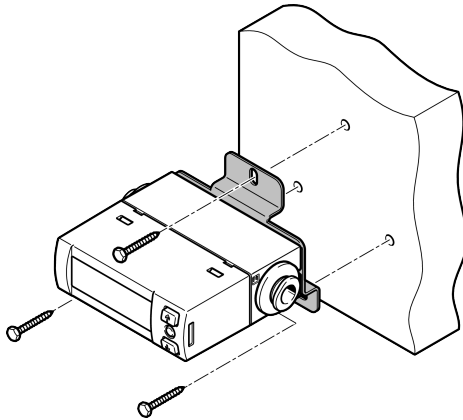

Fig. 8: Wall mounting

1. Screw the wall mounting to the sensor.
 - Tightening torque: maximum 0.5 Nm
2. Install the wall mounting.

5.3 Mounting sensor on plate

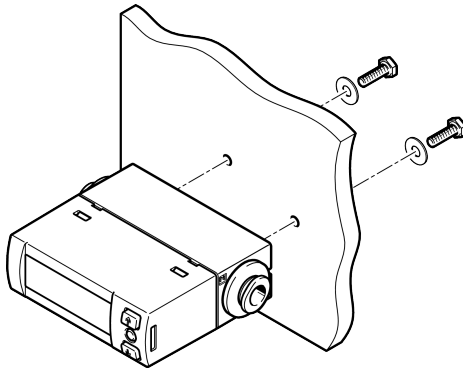

Fig. 9: Mounting on plate

- Fasten the sensor to the plate with screw of the appropriate length.
 - Tightening torque: maximum 0.5 Nm
 - Hole diameter: maximum 3.3 mm

5.4 Mounting sensor on plate at the side

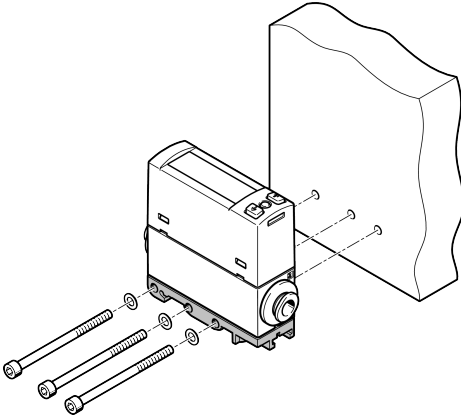

Fig. 10: Plate mounting on the side

1. Mount the H-rail on the sensor.
 - Tightening torque: maximum 0.5 Nm
2. Mount the H-rail mounting on the plate with washers and M4 screws.
 - Tightening torque: maximum 0.5 Nm

5.5 Mounting sensor with front panel mounting kit

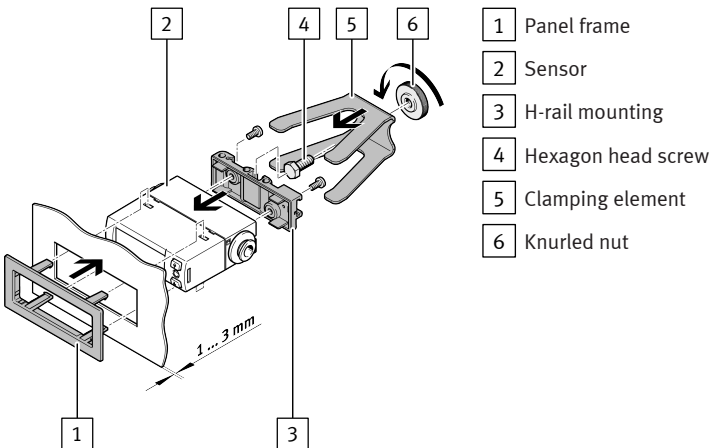

Fig. 11: Front panel mounting kit

1. Mount the H-rail on the sensor.
 - Tightening torque: maximum 0.5 Nm
2. Mount a hexagon head screw on the H-hat rail mounting.
3. Push the panel frame through the cut-out.
 - Cutout: 62 mm x 24 mm ± 0.1 mm

4. Attach the sensor to the panel frame so all 4 snap-in hooks lock into place.
5. Push the clamping element over the hexagon head screw.
6. Lock the sensor with the enclosed knurled nut.
 - Tightening torque: maximum 0.3 Nm

6 Installation

6.1 Pneumatic installation

With the unidirectional sensor SFAH-...U-... the flow rate is fed to the flow port 1 and exits at flow port 2. The direction of flow is indicated on the sensor by an arrow.

i

Unidirectional type only: if the sensor tubing is incorrectly installed, the measured values will be shown with a negative sign and will be outside the specified measurement range.

With the bidirectional sensor SFAH-...B-... the flow rate can be fed to flow port 1 or flow port 2. The flow direction can be set in EDIT mode and shown in the sub-display to display the flow direction on the monitor with the correct sign.

Installing tubing on sensor

- Install the tubing at flow port 1 and flow port 2 → Marking on product.

6.1.1 Infeed situation

The specific accuracies in accordance with the technical data will be reached if the conditions for the laminar flow inlet at the sensor are maintained.

Min. internal diameter of the laminar flow inlet in mm	Design of the laminar flow inlet	Flow measuring range in l/min						
		-0.1	-0.5	-1	-5	-10	-50	-100
2.9	Any	recommended			± 2% ¹⁾		Not recommended ²⁾	
4	Straight	recommended				± 1% ¹⁾		
4	Angle directly on sensor							
4	Distance of the angle in flow direction in front of the sensor: 5 ... 80 cm					± 10% ¹⁾		
6	Any	recommended						

1) Deviation from the specified accuracy.

2) Operation possible. But deviations greater than 20% must be expected.

Tab. 12: Effect of the infeed conditions and port sizes on the specified accuracy

6.2 Electrical installation

⚠ WARNING

Risk of injury due to electric shock.

- Use exclusively PELV circuits in accordance with IEC 60204-1/EN 60204-1 for the electrical power supply (Protective Extra-Low Voltage, PELV).
- Observe the general requirements of IEC 60204-1/EN 60204-1 for PELV circuits.
- Use exclusively voltage sources that guarantee reliable electrical isolation from mains power in accordance with IEC 60204-1/EN 60204-1.

1. Observe the length of the signal line → 12 Technical data.
2. Configure the binary outputs in accordance with their wiring in the SPEC menu → 7.3.2 Configuring the switching output.

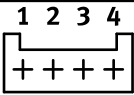
Plug L1	Pin	Wire colour ¹⁾	Allocation
	1	Brown (BN)	Operating voltage +24 V DC
	2	Black (BK)	Switching output OutA, volume pulse/mass pulse or IO-Link (C/Q cable)
	3	White (WH)	Switching output OutB or analogue output
	4	Blue (BU)	0 V

1) Colours are applicable for connecting cables NEBS-L1...

Tab. 13: Pin allocation of plug L1

Circuit diagram SFAH-...-L1

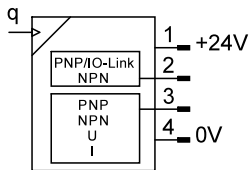
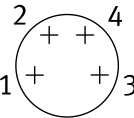

Fig. 12: Circuit diagram

Plug M8 x 1	Pin	Wire colour ¹⁾	Allocation
	1	Brown (BN)	Operating voltage +24 V DC
	2	White (WH)	Switching output OutB or analogue output
	3	Blue (BU)	0 V
	4	Black (BK)	Switching output OutA, volume pulse/mass pulse or IO-Link (C/Q cable)

1) Colours are applicable for connecting cables NEBU-M8...

Tab. 14: Pin allocation of plug M8 x 1

Circuit diagram SFAH-...-M8

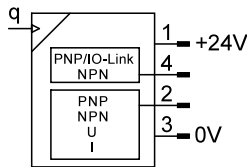

Fig. 13: Circuit diagram

7 Commissioning

7.1 Switching on the sensor in RUN mode

- Switch on the operating voltage.
 - ↳ The current measured value is displayed.

The sensor is in the basic status in RUN mode. The basic status can be reached as follows from other modes:

- Press and hold the [Edit] key for 3 seconds.
- After expiration of a monitoring period (timeout).

Switchover of measured value indicator

The measured value display can be switched between flow rate measurement and volume measurement/mass measurement in RUN mode.

- Switching to flow measurement: press the [A] key.
- Switching to volume measurement/mass measurement: press the [B] key.

7.2 Displaying parameters in SHOW mode

Requirement: the sensor is ready for operation and is in RUN mode.

Switching output OutA or volume pulse/mass pulse at the output

1. Press the [A] key twice in quick succession.
 - ↳ The first set parameter is displayed. 'Fctn' at OutA or 'SP' at pulse flashes.
2. Press the [A] key to display each of the following parameters → Fig. 14.

Switching output OutB or analogue output Anlg

1. Press the [B] key twice in quick succession.
 - ↳ The first set parameter is displayed. 'Fctn' at OutB or 'Out' at Anlg flashes.
2. Press the [B] key to display the following parameters → Fig. 14.

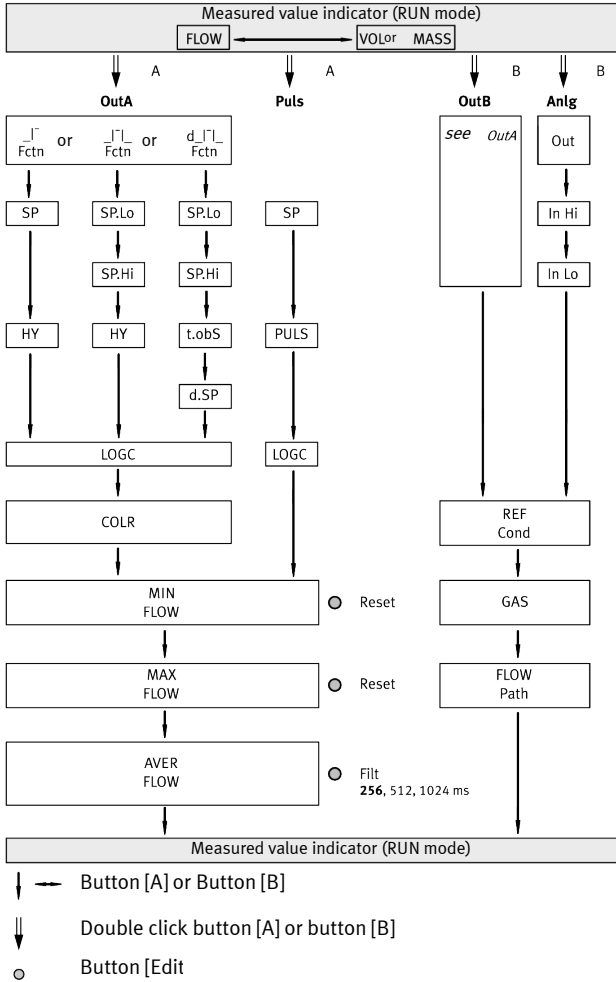
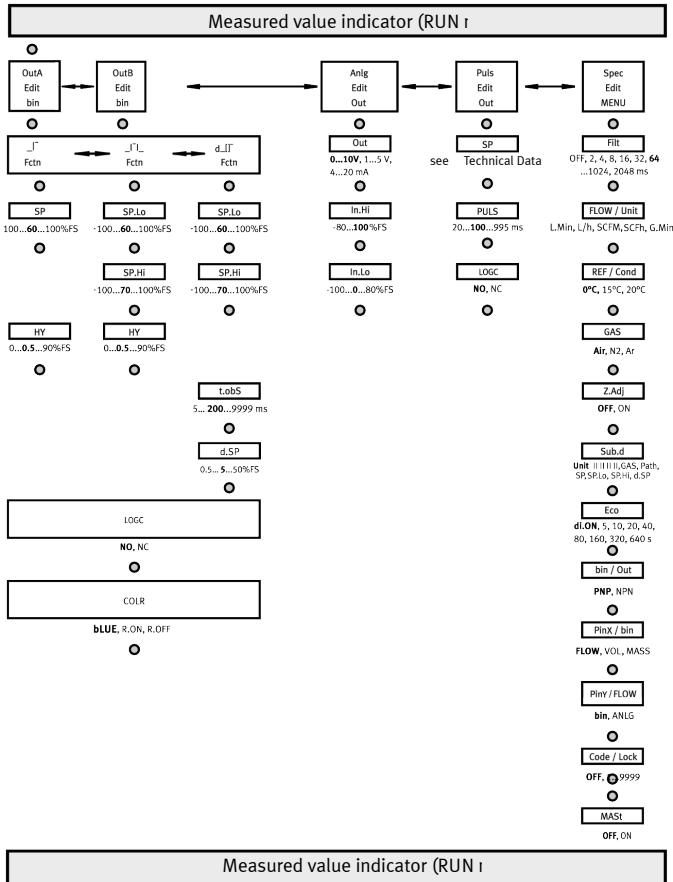

Fig. 14: Menu structure in SHOW mode

7.3 Configuring the sensor in EDIT mode



- Button [A] or Button [B]
- Button [Edit]
- fett Default

Fig. 15: EDIT mode menu structure

i Changes to the switching behaviour are effective immediately.

7.3.1 Entering security code

i If 'Lock' 'IOL' is shown on the display, the sensor is locked by IO-Link Device Access Lock and can only be configured via IO-Link.

Requirement: the sensor is ready for operation and is in RUN mode.

1. Press the [Edit] key.
 - ↳ The EDIT mode is active. 'OutA' flashes.
 - ↳ If the security code is activated, the parameter entry option is blocked: 'Lock' flashes.
2. If the security code is activated, enter the security code with the [A] or the [B] key and press the [Edit] key.
3. Press the [Edit] key.
 - ↳ 'OutA' flashes and the parameter input is unlocked.

7.3.2 Configuring the switching output



The sequence for configuring the OutA and OutB switching outputs is identical. In the following, the process is described using the OutA switching output.

Requirement: the sensor is ready for operation and is in RUN mode.

1. Press the [Edit] key.
 - ↳ 'Edit' is displayed. 'OutA' flashes.
2. Press the [Edit] key.
 - ↳ 'Fctn' flashes.
3. Select the '_|_|', '_|_|_|' or 'd_|_|_|' switching function with the [A] or [B] key.
4. Press the [Edit] key.
 - ↳ The set value is saved.
 - ↳ The next adjustable parameter is shown.
5. Set the parameter with the [A] or [B] key.
6. Repeat steps 4 and 5 until all parameters are set.
7. Press the [Edit] key.
 - ↳ The RUN mode is active.

7.3.3 Changing device settings

Requirement: the sensor is ready for operation and is in RUN mode.

1. Press the [Edit] key.
 - ↵ 'Edit' is displayed. 'OutA' flashes.
2. Select the 'Spec' with the [A] or [B] key.
 - ↵ 'Spec' flashes.
3. Press the [Edit] key.
 - ↵ 'Filt' and 'MSEC' flash alternately.
4. Set the parameter with the [A] or [B] key.
5. Press the [Edit] key.
 - ↵ The set value is saved.
 - ↵ The next adjustable parameter is shown.
6. Repeat steps 4 and 5 until all parameters are set.
7. Press the [Edit] key.
 - ↵ The RUN mode is active.

7.3.4 Setting the volume pulse output

Requirement: the sensor is ready for operation and is in RUN mode.

1. Press the [Edit] key.
 - ↵ 'Edit' is displayed. 'OutA' flashes.
2. Select 'Puls' with the [A] or [B] key.
3. Press the [Edit] key.
 - ↵ 'SP' and the set volume unit flash alternately.
4. Set the parameter with the [A] or [B] key.
5. Press the [Edit] key.
 - ↵ The set value is saved.
 - ↵ The next adjustable parameter is shown.
6. Repeat steps 4 and 5 until all parameters are set.
7. Press the [Edit] key.
 - ↵ The RUN mode is active.

7.3.5 Setting the analogue output

Requirement: the sensor is ready for operation and is in RUN mode.

1. Press the [Edit] key.
 - ↵ 'Edit' is displayed. 'OutA' flashes.
2. Select 'Anlg' with the [A] or [B] key.
3. Press the [Edit] key.
 - ↵ 'Out' and 'V' flash alternately.
4. Set the parameter with the [A] or [B] key.
5. Press the [Edit] key.
 - ↵ The set value is saved.
 - ↵ The next adjustable parameter is shown.

6. Repeat steps 4 and 5 until all parameters are set.
7. Press the [Edit] key.
 - ↳ RUN mode is active.

7.3.6 Replicating parameters

Requirements:

- The previously configured sensor (master sensor) is ready for operation and is in RUN mode.
- The switching output on the device sensor is configured to PNP and is in an unswitched status; the ‘OutA’ indicator is off.
- The master sensor and device sensor have the same design with reference to the parameters, i.e. they have the same device ID.
- The master sensor is connected to the device sensor and the power supply.
- Parameterisation of the device sensor must not be blocked via IO-Link.

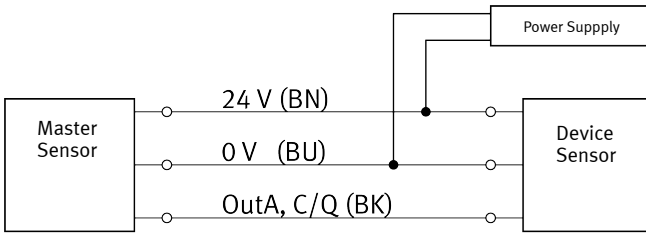

Fig. 16: Replicate pin allocation parameters

1. Select the ‘Spec’ special menu on the master sensor with the device settings.
2. Press the [Edit] key repeatedly until ‘MASt’ is displayed.
3. Select ‘ON’ with the [A] or [B] key.
4. Press the [Edit] key.
 - ↳ ‘REPL’ and ‘REdY’ are displayed alternately.
5. Press the [A] or [B] key.
 - ↳ ‘REPL’ and ‘RUN’ are briefly displayed alternately. The parameters are transmitted to the device sensor. ‘REPL’ and ‘REdY’ are displayed alternately.
 - ↳ In the event of an error, an error message is displayed → 10.1 Fault clearance, → 10.2 Error messages.
6. Repeat point 5 if an additional sensor is to be parameterised.
7. Press the [Edit] key.
 - ↳ The RUN mode is active.

7.3.7 Performing offset adjustment

Requirements:

- Operating pressure is present and there is no flow rate.
- The sensor is ready for operation and is in RUN mode.
- ‘Z.Adj’ ‘ON’ is set → 7.3.3 Changing device settings.
- The measured value lies in the range 0 l/min ± 3 %FS.

- Press the [A] key, the [B] key and the [Edit] key simultaneously.
 - ↳ 'OK' is displayed: the offset adjustment was successful.
 - ↳ 'FAIL' is displayed: the offset adjustment was not successful. Check requirements.



If 'Z.Adj' 'OFF' is set for a later time, the sensor uses the factory-set calibration values.

7.4 Teaching switching points in TEACH mode



If 'Lock' 'IOL' is shown on the display, the sensor is locked by IO-Link Device Access Lock and can only be configured via IO-Link.



The Teach process is the same for configuring the switching outputs for OutA and OutB. In the following, the process is described using the switching output OutA. The Teach function is only available for flow monitoring.

Requirement: the sensor is ready for operation and is in RUN mode.

1. Enter the security code → 7.3.1 Entering security code.
2. Define the switching function in EDIT mode → 7.3.2 Configuring the switching output.
3. Apply signal value 1.
4. Press the [A] key and the [Edit] key.
 - ↳ The current signal value will then be adopted as the first teach point (TP1).
 - ↳ 't-IN' flashes.
5. Apply signal value 2.
6. Press the [A] key and the [Edit] key.
 - ↳ The current signal value will then be adopted as the second teach point (TP2).
 - ↳ The RUN mode is active.

There is no timeout in the TEACH mode. The sensor only switches to RUN mode when the entire teach process has ended.

8 IO-Link interface description

8.1 General information, IO-Link

Characteristics	Specification
Protocol version	Device V1.1
Profile	Smart Sensor Profile
Function classes	Binary data channel (BDC) Process data variable (PDV) Identification Diagnostics Teach channel

IO-Link interface description

Characteristics	Specification
Communication mode	COM2 (38.4 kbaud)
SIO-Mode support	Yes
Port class	A
Process data length IN	3 bytes
Process data content IN	2 bit BDC (flow monitoring) 1 bit BDC (volume monitoring) 14 bit PDV (measured flow rate value)
Service data IN	32 bit volume measurement/mass measurement
Min. cycle time	4 ms
Data storage required	< 0.5 KB
Vendor ID	0x014D (333)
Device ID	→ Tab. 16 Device ID values

Tab. 15: General IO-Link specification

Device ID [dec]	Device ID [hex]	Order code
80	0x000050	SFAH-01U
81	0x000051	SFAH-05U
82	0x000052	SFAH-1U
83	0x000053	SFAH-5U
84	0x000054	SFAH-10U
85	0x000055	SFAH-50U
86	0x000056	SFAH-100U
87	0x000057	SFAH-200U
88	0x000058	SFAH-01B
89	0x000059	SFAH-05B
90	0x00005A	SFAH-1B
91	0x00005B	SFAH-5B
92	0x00005C	SFAH-10B
93	0x00005D	SFAH-50B
94	0x00005E	SFAH-100B
95	0x00005F	SFAH-200B

Tab. 16: Device ID values

8.2 Identification parameters

Index	Sub index	Access ¹⁾	Name	Sample value	String length
0x0010	0	R	Vendor Name	Festo	Max. 32
0x0011	0		Vendor Text	http://www.festo.com	20
0x0012	0		Product Name	SFAH-10B-G18FS-PNLK-PNVBA-M8	Max. 64
0x0013	0		Product ID	8035300 SFAH-01B-M8	Max. 64
0x0014	0		Product Text	Flow sensor for gas media	Max. 32
0x0015	0		Serial Number	3S7PL9V6HHM	11
0x0016	0		Hardware Revision	REV01	5
0x0017	0		Firmware Revision	V51.2.13	8
0x0018	0	R/W	Application Specific Tag	***	32
0x2101	0	R	Part Number	1234567	7

1) R = read, R/W = read and write

Tab. 17: Identification parameters

8.3 IO-Link default parameters

Index	Sub index	Access ¹⁾	Name	Value	Format
0x0002	0	W	System Command	→ 8.4 IO-Link system commands	UInteger8
0x000C	0	R/W	Device Access Locks → Tab. 19 Device Access Locks	0 = unblocked 1 = blocked	Record
0x0020	0	R	Error Count	0	UInteger16
0x0024	0		Device Status	0	UInteger8
0x0025	0		Detailed Device Status	→ 8.11 IO-Link diagnostics	Array of 3 byte records
0x0028	0		Process Data Input	→ 8.9 Process data IN	Record

1) R = read, W = write, R/W = read and write

Tab. 18: IO-Link default parameters

Bit no.	Description
0	Lock write access to parameters
1	Lock data save, no effect
2	Lock entire parameterisation in EDIT mode and TEACH mode
3	Lock UI, not used

Tab. 19: Device Access Locks

8.4 IO-Link system commands

Value [dec]	Value [hex]	Command	Description
65	0x41	SP1 Single Value Teach	Determines Teachpoint for Setpoint SP1
66	0x42	SP2 Single Value Teach	Determines Teachpoint for Setpoint SP2
67	0x43	SP1 Two Value Teach TP1	Determines teach-in point 1 for switching point SP1
68	0x44	SP1 Two Value Teach TP2	Determines teach-in point 2 for switching point SP1
75	0x4B	Specific Teach	Device-specific teach-in
79	0x4F	Teach Cancel	Cancels the Teach sequence
128	0x80	Device reset	Device warm start
130	0x82	Restore factory settings	Sets the factory settings operative again
160	0xA0	Reset Min PDV	Minimal measured flow value reset
161	0xA1	Reset Max PDV	Maximal measured flow value reset
168	0xA8	Adjust flow zero point	User defined flow zero point adjustment
176	0xB0	Reset volume recording/mass recording	Reset volume recording/mass recording in RECORDER mode.
177	0xB1	Start/resume volume recording/mass recording	Start or resume volume/mass logging in RECORDER mode.
178	0xB2	Pause volume recording/mass recording	Pause volume recording/mass recording in RECORDER mode.

Tab. 20: IO-Link system commands

8.5 Smart sensor profile parameters

Index	Sub index	Access ¹⁾	Name	Value	Format
0x000D	0	R	Profile Characteristics	–	Array of Uln- teger16
	1		Device Profile ID	0x0001: Smart Sensor Profile	Uln- teger16
	2		Function Class ID	0x8000: Identifikation	
	3		Function Class ID	0x8001: Binarer Datenkanal (BDC)	
	4		Function Class ID	0x8002: Prozessdatenvariable (PDV)	
	5		Function Class ID	0x8003: Diagnose	
	6		Function Class ID	0x8004: Teach Channel	
0x000E	0	R	PD Input Descriptor	–	Array of Octet- String3
	1		BDC1, BDC2, BDC3	0x01, 0x03, 0x00	Octet- String3
	2		Process data variable	0x02, 0x0E, 0x08	
0x003A	0	R/W	Teach Channel	0: BDC1 (OutA), factory setting 1: BDC1 (OutA) 2: BDC2 (OutB)	Uln- teger8
0x003B	0	R	Teach State	0	Record
	1		teach flag TP2 for SP2	0: not set 1: set	Boo- leanT
	2		teach flag TP1 for SP2	0: not set 1: set	
	3		teach flag TP2 for SP1	0: not set 1: set	
	4		teach flag TP1 for SP1	0: not set 1: set	
	5		Teach State	0	Uln- teger4

IO-Link interface description

Index	Sub index	Access ¹⁾	Name	Value	Format
BDC1, flow rate monitoring OutA					
0x003C	1	R/W	Setpoint SP1	1 ... 16382	UInteger16
	2		Setpoint SP2	1 ... 16382	
0x003D	1		Switchpoint logic	0: NO 1: NC	UInteger8
	2		Switchpoint mode	1: Single point mode 2: Window mode 128: auto difference monitoring	
	3		Setpoint Hysteresis	0 ... 7373	UInteger16
BDC2, flow rate monitoring OutB					
0x003E	1	R/W	Setpoint SP1	1 ... 16382	UInteger16
	2		Setpoint SP2	1 ... 16382	
0x003F	1		Switchpoint logic	0: NO 1: NC	UInteger8
	2		Switchpoint mode	1: Single point mode 2: Window mode 128: auto difference monitoring	
	3		Setpoint Hysteresis	0 ... 7373	UInteger16
BDC3, volume pulse/mass pulse (Puls)					
0x4000	1	R/W	Setpoint	164 ... 4294967295	UInteger32
	2		no used	0	
0x4001	1		Switchpoint logic	0: NO 1: NC	UInteger8
	2		Switchpoint mode	128: volume pulse/mass pulse	
	3		no used	0	UInteger16

1) R = read, R/W = read and write

Tab. 21: Smart sensor profile parameters

8.6 Device-specific parameters

Index	Sub-Index	Access ¹⁾	Name	Value	Format
0x0112	0	R/W	OutA, auto difference monitoring, max. signal change (S.obS)	16 ... 328, Factory setting: 33	UInteger16
0x0113	0		OutA, auto difference monitoring, period (t.obS)	5 ... 9999	
0x0114	0		OutA, auto difference monitoring, monitoring range (d.SP)	41 ... 4096	
0x0118	0		OutA, backlight color (COLR)	0: always blue 1: red, if Out = 0 2: red, if Out = 1	
0x0130	0		OutB, auto difference monitoring, max. signal change (S.obS)	16 ... 328, Factory setting: 33	
0x0131	0		OutB, auto difference monitoring, period (t.obS)	5 ... 9999	
0x0132	0		OutA, auto difference monitoring, monitoring range (d.SP)	41 ... 4096	
0x0136	0		OutB, backlight color (COLR)	0: always blue 1: red, if Out = 0 2: red, if Out = 1	
0x0149	0		Volume pulse/mass pulse width (PULS/MSEC)	20 ... 995 ms	
0x016A	0		Analog output scaling, start value (In.Lo)	-100 ... 80	
0x016B	0	Analog output scaling, end value (In.Hi)	-80 ... 100		
0x016C	0	Analog output type (Out)	0: 0 ... 10 V voltage output 1: 1 ... 5 V voltage output 2: 4 ... 20 mA current output	UInteger16	

IO-Link interface description

Index	Sub-Index	Access ¹⁾	Name	Value	Format
0x017F	0	R/W	flow unit of the display (FLOW/Unit)	0: l/min 1: l/h 2: scfm 3: scfh 4: g/min	UInteger16
0x0181	0		Flow display filter	8: 256 ms 9: 512 ms 10: 1024 ms	
0x0182	0		Filter measured flow rate value PDV (AVER)	0: filter off 1: 2 ms 2: 4 ms 3: 8 ms 4: 16 ms 5: 32 ms 6: 64 ms 7: 128 ms 8: 256 ms 9: 512 ms 10: 1024 ms 11: 2048 ms	
0x0184	0		User zero adjustment on/off (Z.Adj)	0: off 1: on	
0x01DD	0		Measured value display	1: flow rate 2: volume pulse/mass pulse	
0x01E2	0		Output signal at pin Y ²⁾	0: OutB (bin) 1: analogue output for the flow rate signal (Anlg)	
0x01E3	0		Output signal at pin X ³⁾	0: OutA (FLOW) 1: volume pulse/mass pulse (VOL/MASS)	

IO-Link interface description

Index	Sub-Index	Access ¹⁾	Name	Value	Format	
0x01E8	0	R/W	Backlight duration (Eco/SEC)	0: always on 1: 5 s 2: 10 s 3: 20 s 4: 40 s 5: 80 s 6: 160 s 7: 320 s 8: 640 s	UInteger16	
0x01E9	0		Sub-display mode (Sub.d)	0: units 1: bar graph 2: gas 3: flow direction ¹⁾ 4: SP1 5: SP2 6: d.SP		
0x01EA	0		Lock code, local parameter lock	0: off 1 ... 9999 - code		
0x01EE	0		Gas type (GAS)	0: air 1: N2 3: Ar		
0x01F0	0		Reference condition for volume values (REF/Cond)	0: 0 °C 1: 15 °C 2: 20 °C		
0x2001	0	R	PDV, measured flow rate process value	0 ... 2 ¹⁴ - 1	UInteger32	
0x2002	0		PDV, process value of volume measurement/mass measurement for pulse output	0 ... 2 ³² - 1		
0x2004	0		PDV, process value of volume measurement/mass measurement in RECORDER mode	0 ... 2 ³² - 1		
0x2005	0		Min. PDV, minimum measured flow rate value	0 ... 2 ¹⁴ - 1		UInteger16
0x2006	0		Max. PDV, maximum measured flow rate value	0 ... 2 ¹⁴ - 1		

Index	Sub-Index	Access ¹⁾	Name	Value	Format
0x200E	0	R	Runtime of volume measurement since last reset/power on	0 ... $2^{32} - 1$ s	UInteger32
0x200F	0		Runtime of volume measurement in error status of flow rate measurement since last reset/power on	0 ... $2^{32} - 1$ s	

1) R = read, R/W = read and write

2) Pin 2 for SFAH-...-M8; Pin 3 for SFAH-...-L1

3) Pin 4 for SFAH-...-M8; Pin 2 for SFAH-...-L1

Tab. 22: Device-specific parameters

8.7 IO-Link teach-in

The sensor support three different IO-Link teach-in functions for all IO-Link switching channels (BDC):

- Device-specific teach-in
- Single Value teach-in according to IO-Link specification in window mode and in auto difference monitoring
- Two Value teach-in according to IO-Link specification in single-point mode

Carry out the following steps before teach-in:

1. Configure the switching channel according to the application including switching point mode, switching logic and hysteresis.
2. Set the teach-in channel to the desired switching channel (parameter 0x003A, OutA=0x01, OutB=0x02).

The following applies to all teach-in processes:

- The [A], [B] and [Edit] keys are locked during teach-in. 't-IN' and 'IOL' flash alternately on the display.
- The chronological sequence of the teach-in points is not relevant.
- The teach values are only accepted after the second teach-in.
- The teach-in process can be cancelled with the 0x4F command.

Device-specific teach-in

The device-specific teach-in (0x4B) behaves in the same way as the manual teach-in on the device.

The two teach-in points are set with the IO-Link command instead of a manual key press. For teach-in of the single-point mode the switching point is derived from the average of the two teach-in points: $SP = 1/2 (TP1 + TP2)$.

1. Set the first flow rate.
2. Send the teach-in command 0x4B.
3. Set the second flow rate.
4. Send the teach-in command 0x4B.

Single Value Teach-In according to IO-Link specification in window mode

SP1 and SP2 are taught-in with separate commands with the Single Value teach-in. The two teach points are assigned to the switching points SP1 and SP2 in such a way that the parameter set is valid.

1. Set the desired flow rate.
2. Send the teach-in command 0x41 for TP1.
3. Set the second desired flow rate.
4. Send the teach-in command 0x42 for TP2.

Two Value teach-in according to IO-Link specification in single-point mode

With the Two Value teach-in, each teach point is taught in with separate commands for SP1.

1. Set the desired flow rate.
2. Send the teach-in command 0x43 (SP1 Two Value Teach TP1).
3. Set the second desired flow rate.
4. Send the teach-in command 0x44 (SP1 Two Value Teach TP2). The switching point is derived from the average of the two teach points: $SP1 = 1/2 (TP1 + TP2)$.

Recommendation: after teach-in read out and check that the setting conform to the application. For more information see IO-Link Smart Sensor Profile → 8.5 Smart sensor profile parameters.

8.8 Block parameterisation

This function can prevent sending of invalid parameters to a device. Individually sent parameter values may not be compatible with the parameter values already stored in the device. All parameters transmitted as a block will be simultaneously accepted and activated.

Block parameterisation for BDC1 (OutA)

Index	Sub index	Name
0x003C	1	Setpoint SP1
	2	Setpoint SP2
0x003D	2	Switchpoint mode (Fctn)
	3	Hysteresis (HY)
0x0112	0	Auto difference monitoring, max. signal change (S.obS)
0x0113	0	Auto difference monitoring, period (t.obS)
0x0114	0	Auto difference monitoring, signal change (d.SP)

Tab. 23: Block of coherent OutA parameters

Block parameterisation for BDC2 (OutB)

Index	Sub index	Name
0x003E	1	Setpoint SP1
	2	Setpoint SP2
0x003F	2	Switchpoint mode (Fctn)
	3	Hysteresis (HY)

Index	Sub index	Name
0x0130	0	Auto difference monitoring, max. signal change (S.obS)
0x0131	0	Auto difference monitoring, period (t.obS)
0x0132	0	Auto difference monitoring, signal change (d.SP)

Tab. 24: Block of coherent OutB parameters

Block parametrisation for BDC3 (Puls)

Index	Sub index	Name
0x4000	1	Setpoint SP1
0x0149	0	Volume pulse/mass pulse width

Tab. 25: Block of coherent pulse parameters

Block parametrisation for the analogue output

Index	Sub index	Name
0x016A	0	Analog output scaling, start value (In.Lo)
0x016B	0	Analog output scaling, end value (In.Hi)

Tab. 26: Block of coherent parameters for the analogue output

8.9 Process data IN

Bit	23	22	21	20	19	18	17	16	15	14	13	12	11	10	9	8
Meaning	no used		MSB													LSB
Process data			PDV flow rate													
Data content			14 bit PDV measured value													
Index			0x0028													
SubIndex			1													
Data type			UInteger14													

Tab. 27: Process data IN PDV

Bit	7	6	5	4	3	2	1	0
Process data	no used					BDC3	BDC2	BDC1
Data content						Puls	OutB	OutA
Index						0x0028		

Bit	7	6	5	4	3	2	1	0
SubIndex	no used					2	3	4
Data type						Boolean		

Tab. 28: Process data IN BDC

8.10 Conversion factors

Fixed conversion factors are required for the physical units in order to display the measured and process value-related parameters correctly in the control unit. The conversion factors for the volume units are based on the reference standard DIN 1343 and the gas medium air.

- For other reference standards and gas media, use factors from the following chapters:
 - → 4.2.4 Standard switching condition for volume values - 'REF'/'Cond'
 - → 8.10.4 Scaling factors for gases

8.10.1 Conversion factors for process data variable, process data variable min, process data variable max, and setpoint values SP1, SP2

Flow rate unit	SFAH-0.1		SFAH-0.5	
	Gradient	Offset	Gradient	Offset
l/min	0.000012207776	-0.1	0.000061038882	-0.5
l/h	0.000732466581	-6	0.003662332906	-30
scft/min	0.000000431114	-0.00353147	0.000002155570	-0.01765735
scft/h	0.000025866838	-0.2118882	0.000129334188	-1.059441
g/min	0.000015783434	-0.12929	0.00007891717	-0.64645

Tab. 29: Conversion factors

Flow rate unit	SFAH-1		SFAH-5	
	Gradient	Offset	Gradient	Offset
l/min	0.000122077764	-1.0	0.000610388818	-5.0
l/h	0.007324665812	-60	0.036623329061	-300
scft/min	0.000004311140	-0.03531470	0.000021555698	-0.1765735
scft/h	0.000258668376	-2.118882	0.001293341879	-10.59441
g/min	0.00015783434	-1.2929	0.000789171702	-6.4645

Tab. 30: Conversion factors

Flow rate unit	SFAH-10		SFAH-50	
	Gradient	Offset	Gradient	Offset
l/min	0.001220777635	-10	0.006103888177	-50
l/h	0.073246658121	-600	0.366233290606	-3000
scft/min	0.000043111396	-0.35314700	0.000215556980	-1.76573500
scft/h	0.002586683758	-21.18882	0.012933418788	-105.9441
g/min	0.001578343405	-12.929	0.007891717024	-64.645

Tab. 31: Conversion factors

Flow rate unit	SFAH-100		SFAH-200	
	Gradient	Offset	Gradient	Offset
l/min	0.012207776354	-100	0.024415552707	-200
l/h	0.732466581212	-6000	1.464933162424	-12000
scft/min	0.000431113960	-3.53147000	0.000862227919	-7.06294000
scft/h	0.025866837576	-211.8882	0.051733675151	-423.7764
g/min	0.015783434047	-129.29	0.031566868095	-258.58

Tab. 32: Conversion factors

8.10.2 Conversion factors for hysteresis, switching point d.SP and max. signal delta (S.obs)

Flow rate unit	SFAH-0.1		SFAH-0.5		SFAH-1	
	Gradient	0 ¹⁾	Gradient	0 ¹⁾	Gradient	0 ¹⁾
l/min	0.000012207776	0	0.000061038882	0	0.000122077764	0
l/h	0.000732466581	0	0.003662332906	0	0.007324665812	0
scft/min	0.000000431114	0	0.000002155570	0	0.000004311140	0
scft/h	0.000025866838	0	0.000129334188	0	0.000258668376	0
g/min	0.000015783434	0	0.00007891717	0	0.00015783434	0

1) Offset

Tab. 33: Conversion factors

Flow rate unit	SFAH-5		SFAH-10		SFAH-50	
	Gradient	0 ¹⁾	Gradient	0 ¹⁾	Gradient	0 ¹⁾
l/min	0.000610388818	0	0.001220777635	0	0.006103888177	0
l/h	0.036623329061	0	0.073246658121	0	0.366233290606	0
scft/min	0.000021555698	0	0.000043111396	0	0.000215556980	0

Flow rate unit	SFAH-5		SFAH-10		SFAH-50	
	Gradient	O ¹⁾	Gradient	O ¹⁾	Gradient	O ¹⁾
scft/h	0.001293341879	0	0.002586683758	0	0.012933418788	0
g/min	0.000789171702	0	0.001578343405	0	0.007891717024	0

1) Offset

Tab. 34: Conversion factors

Flow rate unit	SFAH-100		SFAH-200	
	Gradient	Offset	Gradient	Offset
l/min	0.012207776354	0	0.024415552707	0
l/h	0.732466581212	0	1.464933162424	0
scft/min	0.000431113960	0	0.000862227919	0
scft/h	0.025866837576	0	0.051733675151	0
g/min	0.015783434047	0	0.031566868095	0

Tab. 35: Conversion factors

8.10.3 Conversion factors for volume units and mass units

Variant	Volume units and mass units			
		l	scft	g
SFAH-0.1	G ¹⁾	0.000006103888	0.000000215557	0.000007891717
	O ²⁾	0	0	0
SFAH-0.5	G	0.000030519441	0.000001077785	0.000039458585
	O	0	0	0
SFAH-1	G	0.000061038882	0.000002155570	0.000078917170
	O	0	0	0
SFAH-5	G	0.000305194409	0.000010777849	0.000394585851
	O	0	0	0
SFAH-10	G	0.000610388818	0.000021555698	0.000789171702
	O	0	0	0
SFAH-50	G	0.003051944088	0.00010777849	0.003945858512
	O	0	0	0
SFAH-100	G	0.006103888177	0.00021555698	0.007891717024
	O	0	0	0

Variant		Volume units and mass units		
		l	scft	g
SFAH-200	G	0.012207776354	0.00043111396	0.015783434047
	O	0	0	0

1) G = gradient

2) O = offset

Tab. 36: Conversion factors for volume units and mass units

8.10.4 Scaling factors for gases

Gas	Factor
Compressed air	1
Nitrogen (N2)	0.987
Argon	1

Tab. 37: Scaling factors for gases

8.11 IO-Link diagnostics

Event code	Event type	Device status	Local display	Possible cause
0x1802	Error	Failure	'Er02' 'ASIC'	IO-Link- driver error
0x1803	Error	Failure	'Er03' 'SEnS'	– Sensor unit failure – Device faulty
0x1809	Warning	Out-of-Specification	Measured value 'Er09'/'UNdR'	Range of flow sensing undershot
0x180A	Warning	Out-of-Specification	Measured value 'Er10'/'OVER'	Range of flow sensing undershot
0x1815	Error	Out-of-Specification	Measured value 'Er21'/'SHRT'	Overload or short circuit at switching output OutA/pulse
0x1816	Error	Out-of-Specification	Measured value 'Er22'/'SHRT'	Overload or short circuit at switching output OutB
0x181F	Notification	Device is operating properly	no effect	Volume recording/mass recording overflow
0x4000	Error	Failure	Measured value 'Er20'/'tEMP'	Temperature error in IO-Link driver

Event code	Event type	Device status	Local display	Possible cause
0x5000	Error	Failure	'Er01' 'FAIL'	Device hardware fault
0x5111	Warning	Out-of-Specification	Measured value 'Er17'/'SUPL'	Power supply too low

Tab. 38: IO-Link diagnostics

9 Operation

9.1 Switching on the Sensor

After switching on the supply voltage, the sensor requires a warm-up time of 10 minutes before it reaches the specified accuracy. The flow rate displayed by the sensor refers to the standard conditions that have been set in the SPEC menu under Options.

9.2 Restoring factory settings (Restore)

i

The current settings of the sensor will be lost if factory settings are restored.

1. Switch off the operating voltage.
2. Press and hold the [A] and [B] keys.
3. Switch on the operating voltage.
4. Also press the [Edit] key.
 - ↗ 'RSto PArM' is displayed.
 - ↗ All parameters are reset to the factory settings.

10 Malfunctions

10.1 Fault clearance

Troubleshooting communication interface → 8.11 IO-Link diagnostics

Malfunction	Cause	Remedy
No display	No operating voltage or impermissible operating voltage.	Apply permissible operating voltage.
	Electrical connections swapped.	Connect the device in accordance with the circuit diagram.
	Device faulty.	Replace device.
	Economy mode set.	Press key or switch off economy mode.

Malfunction	Cause	Remedy
Indicator or switching output does not react as expected	Short circuit or overload at the output.	Eliminate short circuit or overload.
	Incorrect switching point taught, e.g. at 0 l/min.	Repeat teach-in.
	Incorrect standard condition for volumetric flow rate set.	Correct standard condition.
	Device faulty.	Replace device.
	Parameter incorrect.	Reset to factory settings.

Tab. 39: Fault clearance

10.2 Error messages

Fault description	Cause	Remedy
'Er01'/'FAIL' ¹⁾	Device faulty	Replace device.
'Er02'/'ASIC' ¹⁾		
'Er03'/'SEnS' ¹⁾		
'Er09'/'UndR'	Below sensing range	Maintain sensing range.
'Er10'/'OVER'	Sensing range exceeded	Maintain sensing range.
'Er17'/'SUPL' ²⁾	Undervoltage	Maintain permissible operating voltage.
'Er20'/'t.Hi' ²⁾	Temperature fault	Check operating conditions.
		Check ambient temperature.
		Check wiring.
		Replace device.
'Er21'/'SHRt' ²⁾	Short circuit at OutA/"Puls"	Eliminate short circuit.
'Er22'/'SHRt' ²⁾	Short circuit at OutB	Eliminate short circuit.
'Err'/'bUSY'	OutA/"Puls" is switched active in the device sensor	Check device settings.
'Err'/'Id'	Device ID error, devices do not have the same design	Use sensors with the same flow rate measurement range (same device ID) for replicating.

Fault description	Cause	Remedy
'Err'/'COM'	IO-Link communication error	Check settings of the device sensor.
		Check line.

1) Display flashes red

2) Display is red

Tab. 40: Error messages

11 Removal

1. Turn off energy source and compressed air.
2. Disconnect connections from the sensor.
3. Loosen the mountings.

12 Technical data

12.1 Technical data, general

General	
Certification	RCM compliance mark, c UL us Listed (OL)
Certificates, declaration of conformity	➔ www.festo.com/sp
Note on materials	RoHS-compliant

Tab. 41: General

Input signal and measuring element		
Measured variable		– Volumetric flow rate – Mass flow rate
Flow direction		– Unidirectional – Bidirectional
Measurement principle		Thermal
Measurement method		Heat transfer
Warm-up time	[min]	10
Operating pressure	[MPa]	–0.09 ... 1
	[bar]	–0.9 ... 10
	[psi]	–13 ... 145
Temperature of medium	[°C]	0 ... 50
Ambient temperature	[°C]	0 ... 50

Input signal and measuring element	
Operating medium	<ul style="list-style-type: none"> – Compressed air to ISO 8573-1:2010 [6:4:4] – Nitrogen – Argon
Nominal conditions for determination of the accuracy specification.	<ul style="list-style-type: none"> – Operating pressure at output: 0 kPa relative – Medium and ambient temperature: 23°C – Analogue output: voltage with 20 kΩ load – Switching output: load current in the switched status 5 mA – Mounting position: horizontal, display upwards – Inflow: ➔ 6.1.1 Infeed situation

Tab. 42: Input signal and measuring element

Output, general		
Accuracy of zero point compressed air, nitrogen	[% FS]	± 1
Accuracy of zero point argon	[% FS]	± 2
Repetition accuracy of zero point	[% FS]	± 0.2
Repetition accuracy of spread	[% FS]	± 0.8
Temperature coefficient zero point	[% FS/K]	Typ. 0 (max. 0.05)
Temperature coefficient of spread	[% FS/K]	Typ. 0.15 (max. 0.3)
Position dependency of zero point with vertical mounting	[% FS/100 kPa]	± 0.5
Accuracy of spread		
– Without using the compressed air, nitrogen flow outlet	[% FS]	± 2
– Without using the argon flow outlet	[% FS]	± 4
– With use of the compressed air, nitrogen current outlet	[% FS]	± 3.5
– With use of the argon flow outlet	[% FS]	± 7

Output, general		
Pressure influence of spread		
- In the pressure range -70 ... +1000 kPa	[% FS]	Typ. ± 1
- In the pressure range -90 ... - 70 kPa	[% FS]	Typ. ± 4

Tab. 43: Output, general

Switching output	
Switching output	2 PNP or 2 NPN, switchable
Switching function	Threshold value comparator, window comparator, auto difference monitoring
Switching element function	N/C contact or N/O contact, switchable
Max. output current [mA]	100
Voltage drop [V]	Max. 1
Max. switch-on time [ms]	6 (at Filt = OFF)
Max. switch-off time [ms]	5 (at Filt = OFF)
Pull down resistor [ms]	PNP: integrated
Pull-up resistor [ms]	NPN: not integrated Load current of at least 2 mA required
Inductive protective circuit	Present

Tab. 44: Switching output

Analogue output	Variant	SFAH-...U-	SFAH-...B
Characteristic flow rate curve [l/min]	-0.1...-	0 ... 0.1	-0.1 ... 0.1
	-0.5...-	0 ... 0.5	-0.5 ... 0.5
	-1...-	0 ... 1	-1 ... 1
	-5...-	0 ... 5	-5 ... 5
	-10...-	0 ... 10	-10 ... 10
	-50...-	0 ... 50	-50 ... 50
	-100...-	0 ... 100	-100 ... 100
	-200...-	0 ... 200	-200 ... 200
Voltage output characteristic curve [V]	All	0 ... 10 or 1 ... 5	

Technical data

Analogue output	Variant	SFAH-...U-	SFAH-...B
Current output characteristic [mA] curve	All	4 ... 20	
Max. load resistance of current output [Ω]	All	500	
Min. load resistance of voltage output [$k\Omega$]	All	20	
Rise time [ms]	All	Max. 3 (with Filt = Off)	

Tab. 45: Analogue output

Output, additional data	
Short circuit current rating	Yes
Overload protection	Present

Tab. 46: Output, additional data

Electronics	
Operating voltage range [V DC]	22 ... 26
Max. no-load supply current [mA]	25
Reverse polarity protection	For all electrical connections

Tab. 47: Electronics

Electromechanics	SFAH-...-M8	SFAH-...-L1
Connection type	Plug	
Connection technology	M8x1 A-cod., according to EN 61076-2-104	Plug pattern L1J
Number of pins/wires	4	
Max. connecting cable length [m]	30 20 with IO-Link operation	

Tab. 48: Electromechanics

Mechanics	
Mounting position	Any
Pneumatic connection	→ Tab. 12 Effect of the infeed conditions and port sizes on the specified accuracy
Product weight [g]	Approx. 90

Mechanics	
Note on materials for housing	PA-reinforced
Materials in contact with medium	<ul style="list-style-type: none"> - NBR - PA-reinforced - High-alloy stainless steel - Anodised wrought aluminium alloy - Silicon - Silicon nitride - Epoxy

Tab. 49: Mechanics

Display, operation	
Displayable units for the variants - SFAH-0.1 - SFAH-0.5 - SFAH-1	l/min, l/h, scft/h, g/min, l, scft, g
Displayable units for the variants - SFAH-5 - SFAH-10	l/min, l/h, scft/min, scft/h, g/min, l, scft, g
Displayable units for the variants - SFAH-50 - SFAH-100 - SFAH-200	l/min, scft/min, scft/h, g/min, l, scft, g
Setting range of volume threshold values for the variant - SFAH-0.1	<ul style="list-style-type: none"> - 0.001 ... 9.999 l - 0.001 ... 9.999 sft³ - 0.001 ... 9.999 g
Setting range of volume threshold values for the variants - SFAH-0.5 - SFAH-1	<ul style="list-style-type: none"> - 0.01 ... 99.99 l - 0.001 ... 9.999 sft³ - 0.01 ... 99.99 g
Setting range of volume threshold values for the variant - SFAH-5	<ul style="list-style-type: none"> - 0.1 ... 999.9 l - 0.001 ... 9.999 sft³ - 0.1 ... 999.9 g
Setting range of volume threshold values for the variant - SFAH-10	<ul style="list-style-type: none"> - 0.1 ... 999.9 l - 0.01 ... 99.99 sft³ - 0.1 ... 999.9 g

Display, operation	
Setting range of volume threshold values for the variant – SFAH-50	– 1 ... 9999 l – 0.01 ... 99.99 sft ³ – 1 ... 9999 g
Setting range of volume threshold values for the variants – SFAH-100 – SFAH-200	– 1 ... 9999 l – 0.1 ... 999.9 sft ³ – 1 ... 9999 g
Zero range hiding [%FS]	< 1.5 (Z.Adj = OFF)

Tab. 50: Display, operation

Flow rate measuring range [l/min]	-0.1	-0.5	-1	-5	-10	-50	-100	-200
Start value	0.002	0.01	0.02	0.1	0.2	1	2	4
End value	0.1	0.5	1	5	10	50	100	200

Tab. 51: Flow rate measuring range unidirectional or bidirectional

Flow rate measuring range [l/min]	-0.1B	-0.5B	-1B	-5B	-10B	-50B	-100B	-200B
Start value	-0.002	-0.01	-0.02	-0.1	-0.2	-1	-2	-4
End value	-0.1	-0.5	-1	-5	-10	-50	-100	-200

Tab. 52: Flow rate measuring range bidirectional, supplementary

Immission and emission	-0.1	-0.5	-1	-5	-10	-50	-100	-200
Storage temperature [°C]	-20 ... 80							
Degree of protection	IP40							
Pressure drop at 600 kPa at input and q max. [kPa]	< 0.5					1.2	1.5	1.6
Pressure drop at 0 kPa at output and q max. [kPa]	< 0.5					7.5	10	30
Standard nominal flow rate (600 → 500 kPa) [l/min]	57	93	121	361	445	458	490	870

Tab. 53: Immission and emission

12.2 Technical data for UL/CSA certification

Electrical data and ambient conditions for UL/CSA	
Rated supply voltage	24 V DC
Input current	max. 0.23 A
Operating pressure	max. 1.0 MPa
Pollution degree	3
Humidity range	0 ... 93 %
NEMA enclosure type number (Enclosure Type Rating)	UL Type 1
Installation site	for indoor use only
Max. installation height	2000 m
Degree of protection	The degree of protection IP40 is not UL-tested.

Tab. 54: Electrical data and ambient conditions for UL/CSA

12.3 Examples for calculating the maximum error of the display

- Flow measuring range: 1 ... 50 l/min (FS = 50)
- Measured value: 35 l/min

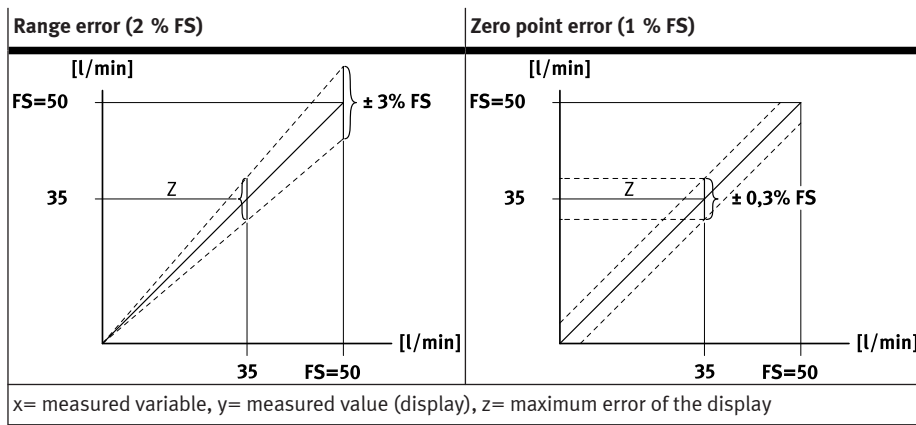

Tab. 55: Spread error and zero point error

Spread error and zero point error

The spread error is proportional to the measured value. At the measured value of 35 l/min the spread error is $35/50$ of 2% of 50 l/min = 0.7 l/min.

The zero point error is independent of the measured value. It is 1% of 50 l/min (FS) = 0.5 l/min.

Errors in the display under nominal conditions (0 bar relativ, 23 °C):

The display error under nominal conditions is the result of adding the spread and zero point errors.

Technical data

The actual flow rate is therefore in the range $35 \pm (0.7 + 0.5) \text{ l/min} = 35 \pm 1.2 \text{ l/min}$.

Errors in the display under deviating nominal conditions (e.g. 6 bar relative, 40 °C, vertical mounting position and display at front):

Typical temperature errors and pressure errors are spread errors. The temperature error at 40 °C and measured value 35 l/min is $35/50$ of 0.15% of 50 l/min * (40 °C – 23 °C) = $\pm 0.89 \text{ l/min}$.

The pressure error at 6 bar relative and measured value 35 l/min is $35/50$ of 1% of 50 l/min = $\pm 0.35 \text{ l/min}$.

The error due to position dependence is a zero point error. This error, with vertical mounting position and the front-facing display, is $35 \text{ l/min} = 0.5\%$ of 50 l/min * 6 = $\pm 1.5 \text{ l/min}$ for the measured value.

The error of the display under deviating nominal conditions is derived from addition of the error values spread, zero point, temperature, pressure and mounting position.

The actual flow rate is in the range $35 \pm (0.7 + 0.5 + 0.89 + 0.35 + 1.5) \text{ l/min} = 35 \pm 3.94 \text{ l/min}$.

Copyright:
Festo SE & Co. KG
Ruiter Straße 82
73734 Esslingen
Germany

Phone:
+49 711 347-0

Internet:
www.festo.com