



# AFM60I-BEPC262144

AFS/AFM60 SSI

**ABSOLUTE ENCODERS**

**SICK**  
Sensor Intelligence.

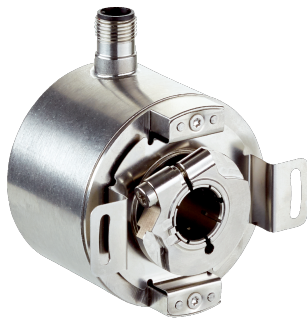

Illustration may differ



### Ordering information

| Type              | Part no. |
|-------------------|----------|
| AFM60I-BEPC262144 | 1083995  |

Other models and accessories → [www.sick.com/AFS\\_AFM60\\_SSI](http://www.sick.com/AFS_AFM60_SSI)

### Detailed technical data

#### Performance

|   |                                   |
|---|-----------------------------------|
| <b>Number of steps per revolution (max. resolution)</b>                         | 262,144 (18 bit)                  |
| <b>Number of revolutions</b>  | 4,096 (12 bit)                    |
| <b>Max. resolution (number of steps per revolution x number of revolutions)</b> | 18 bit x 12 bit (262,144 x 4,096) |
| <b>Measuring step deviation</b>   | ± 0.002° pulses > 10,000          |
| <b>Error limits G</b>   | 0.03° <sup>1)</sup>               |
| <b>Repeatability standard deviation <math>\sigma</math>,</b>                    | 0.002° <sup>2)</sup>              |

<sup>1)</sup> In accordance with DIN ISO 1319-1, position of the upper and lower error limit depends on the installation situation, specified value refers to a symmetrical position, i.e. deviation in upper and lower direction is the same.

<sup>2)</sup> In accordance with DIN ISO 55350-13; 68.3% of the measured values are inside the specified area.

#### Interfaces

|  |  |
|--|--|
| <b>Communication interface</b>                 | SSI  |
| <b>Initialization time</b>                     | 50 ms <sup>1)</sup>                                  |
| <b>Position forming time</b>                   | < 1 $\mu$ s  |
| <b>Code type</b>                               | Gray   |
| <b>Code sequence parameter adjustable</b>      | CW/CCW (V/R)   |
| <b>Interface signals</b>                       | Clock +, Clock -, Data +, Data -                     |
| <b>Clock frequency</b>                         | 2 MHz <sup>2)</sup>                                  |
| <b>Set (electronic adjustment)</b>             | H-active (L = 0 - 3 V, H = 4,0 - U <sub>s</sub> V)   |
| <b>CW/CCW (counting sequence when turning)</b> | L-active (L = 0 - 1,5 V, H = 2,0 - U <sub>s</sub> V) |

<sup>1)</sup> Valid positional data can be read once this time has elapsed.

<sup>2)</sup> SSI max. clock frequency 2 MHz, and min. LOW level (Clock+): 500 ns.

## Electrical data

|  |  |
|--|--|
| <b>Connection type</b>                       | Male connector, M12, 8-pin, radial       |
| <b>Supply voltage</b>                        | 4.5 ... 32 V DC                          |
| <b>Power consumption</b>                     | ≤ 0.5 W (without load)                   |
| <b>Reverse polarity protection</b>           | ✓  |
| <b>MTTFd: mean time to dangerous failure</b> | 250 years (EN ISO 13849-1) <sup>1)</sup> |

<sup>1)</sup> This product is a standard product and does not constitute a safety component as defined in the Machinery Directive. Calculation based on nominal load of components, average ambient temperature 40 °C, frequency of use 8760 h/a. All electronic failures are considered hazardous. For more information, see document no. 8015532.

## Mechanical data

|                                       |                                       |
|---------------------------------------|---------------------------------------|
| <b>Mechanical design</b>              | Blind hollow shaft                    |
| <b>Shaft diameter</b>                 | 12 mm                                 |
| <b>Weight</b>                         | 0.5 kg <sup>1)</sup>                  |
| <b>Shaft material</b>                 | Stainless steel V2A                   |
| <b>Flange material</b>                | Stainless steel V2A                   |
| <b>Housing material</b>               | Stainless steel V2A                   |
| <b>Start up torque</b>                | 1 Ncm (+20 °C)                        |
| <b>Operating torque</b>               | 0.5 Ncm (+20 °C)                      |
| <b>Permissible movement static</b>    | ± 0.3 mm (radial)<br>± 0.5 mm (axial) |
| <b>Permissible movement dynamic</b>   | ± 0.1 mm (radial)<br>± 0.1 mm (axial) |
| <b>Operating speed</b>                | 6,000 min <sup>-1</sup> <sup>2)</sup> |
| <b>Moment of inertia of the rotor</b> | 40 gcm <sup>2</sup>                   |
| <b>Bearing lifetime</b>               | 3.0 x 10 <sup>9</sup> revolutions     |
| <b>Angular acceleration</b>           | ≤ 500,000 rad/s <sup>2</sup>          |

<sup>1)</sup> Based on devices with male connector.

<sup>2)</sup> Allow for self-heating of 3.3 K per 1,000 rpm when designing the operating temperature range.

## Ambient data

|                                      |  |
|--------------------------------------|--|
| <b>EMC</b>                           | According to EN 61000-6-2 and EN 61000-6-3 <sup>1)</sup>                                     |
| <b>Enclosure rating</b>              | IP67, shaft side (IEC 60529)<br>IP67, Housing side, male connector (IEC 60529) <sup>2)</sup> |
| <b>Permissible relative humidity</b> | 90 % (Condensation not permitted)  |
| <b>Operating temperature range</b>   | -40 °C ... +100 °C <sup>3)</sup><br>-30 °C ... +100 °C <sup>4)</sup>                         |
| <b>Storage temperature range</b>     | -40 °C ... +100 °C, without package  |
| <b>Resistance to shocks</b>          | 100 g, 6 ms (EN 60068-2-27)  |
| <b>Resistance to vibration</b>       | 10 g, 10 Hz ... 2,000 Hz (EN 60068-2-6)  |

<sup>1)</sup> EMC according to the standards quoted is achieved if shielded cables are used.

<sup>2)</sup> With mating connector fitted.

<sup>3)</sup> Stationary position of the cable.

<sup>4)</sup> Flexible position of the cable.

## Classifications

|                       |          |
|-----------------------|----------|
| <b>ECLASS 5.0</b>     | 27270502 |
| <b>ECLASS 5.1.4</b>   | 27270502 |
| <b>ECLASS 6.0</b>     | 27270590 |
| <b>ECLASS 6.2</b>     | 27270590 |
| <b>ECLASS 7.0</b>     | 27270502 |
| <b>ECLASS 8.0</b>     | 27270502 |
| <b>ECLASS 8.1</b>     | 27270502 |
| <b>ECLASS 9.0</b>     | 27270502 |
| <b>ECLASS 10.0</b>    | 27270502 |
| <b>ECLASS 11.0</b>    | 27270502 |
| <b>ECLASS 12.0</b>    | 27270502 |
| <b>ETIM 5.0</b>       | EC001486 |
| <b>ETIM 6.0</b>       | EC001486 |
| <b>ETIM 7.0</b>       | EC001486 |
| <b>ETIM 8.0</b>       | EC001486 |
| <b>UNSPSC 16.0901</b> | 41112113 |

Dimensional drawing (Dimensions in mm (inch))

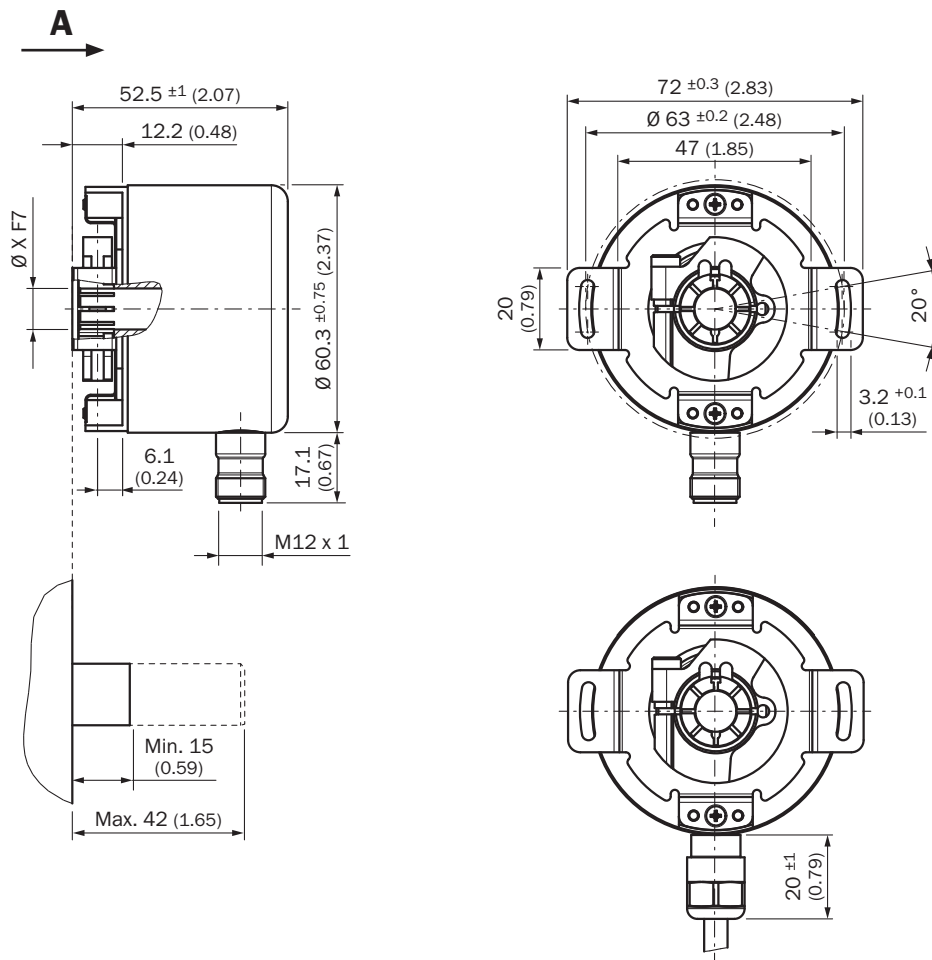

PIN assignment

M12 male connector, 8-pin and cable, 8-wire, SSI/Gray

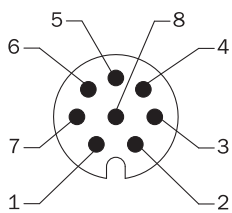

View of M12 male device connector on encoder

| PIN | Wire colors (cable connection) | Signal  | Explanation                                |
|-----|--------------------------------|---------|--|
| 1   | Brown                          | Data -  | Interface signals                          |
| 2   | White                          | Data +  | Interface signals                          |
| 3   | Black                          | V/R     | Sequence in direction of rotation          |
| 4   | Pink                           | SET     | Electronic adjustment<br>Interface signals |
| 5   | Yellow                         | Clock + | Interface signals                          |

| PIN | Wire colors (cable connection) | Signal         | Explanation   |
|-----|--------------------------------|----------------|---|
| 6   | Purple                         | Clock -        | Interface signals   |
| 7   | Blue                           | GND            | Ground connection   |
| 8   | Red                            | U <sub>S</sub> | Operating voltage   |
|     |                                | Screen         | Screen connected to housing on encoder side. Connected to ground on control side. |

### Diagrams

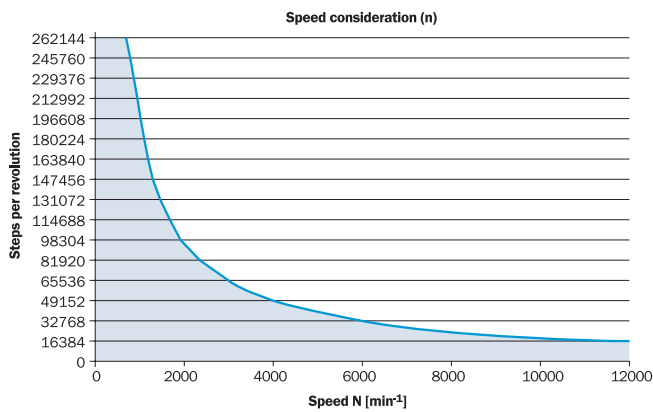

The maximum speed is also dependent on the shaft type.

## SICK AT A GLANCE

SICK is one of the leading manufacturers of intelligent sensors and sensor solutions for industrial applications. A unique range of products and services creates the perfect basis for controlling processes securely and efficiently, protecting individuals from accidents and preventing damage to the environment.

We have extensive experience in a wide range of industries and understand their processes and requirements. With intelligent sensors, we can deliver exactly what our customers need. In application centers in Europe, Asia and North America, system solutions are tested and optimized in accordance with customer specifications. All this makes us a reliable supplier and development partner.

Comprehensive services complete our offering: SICK LifeTime Services provide support throughout the machine life cycle and ensure safety and productivity.

For us, that is “Sensor Intelligence.”

## WORLDWIDE PRESENCE:

Contacts and other locations –[www.sick.com](http://www.sick.com)