



AOD1-SR25Q2

SICK
Sensor Intelligence.



Ordering information

Type	Part no.
AOD1-SR25Q2	6054273

Other models and accessories → www.sick.com/

Detailed technical data

Technical specifications

Accessory family	Evaluation units
System part	Slave
Additional function	Arithmetic calculations (addition, subtraction, absolute subtraction)
Connection type head A	Male connector, M12, 5-pin
Switching output	2 x PNP/NPN, selectable
Multifunctional input (MF)	External teach, zero reset, laser off
Housing material	Polycarbonate
Operating voltage	DC 12 V (-10 %) ... DC 24 V (+10 %)
Power consumption	≤ 2 W ¹⁾
Note	Not free of paint wetting impairment substances.
Operating temperature	-25 °C ... +50 °C
Enclosure rating	IP50
Weight	120 g
Description	OD Mini evaluation unit, slave, 2 x Q, M12 male connector, 5-pin

¹⁾ Without connected sensor heads.

Classifications

ECLASS 5.0	27270890
ECLASS 5.1.4	27270890
ECLASS 6.0	27270890
ECLASS 6.2	27270890
ECLASS 7.0	27270890
ECLASS 8.0	27270890
ECLASS 8.1	27270890
ECLASS 9.0	27270892
ECLASS 10.0	27270892
ECLASS 11.0	27270892
ECLASS 12.0	27270992
ETIM 5.0	EC001825
ETIM 6.0	EC001825
ETIM 7.0	EC001825
ETIM 8.0	EC001825

UNSPSC 16.0901

41111613

Dimensional drawing (Dimensions in mm (inch))

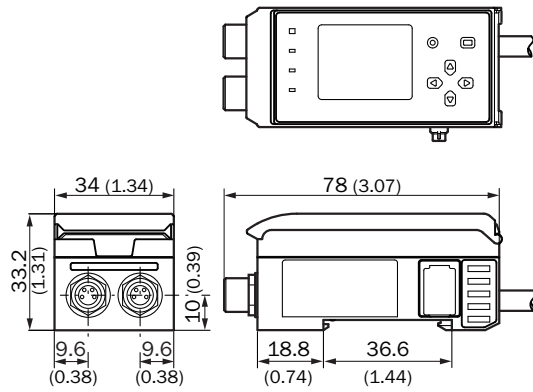

Anschlussschema

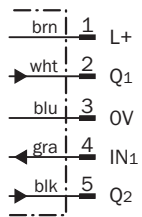

PIN assignment

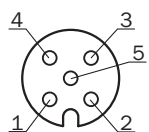

- ① L+
- ② Q₁: Digital output PNP/NPN
- ③ 0 V
- ④ IN₁: Digital input
- ⑤ Q₂: Digital output PNP/NPN

SICK AT A GLANCE

SICK is one of the leading manufacturers of intelligent sensors and sensor solutions for industrial applications. A unique range of products and services creates the perfect basis for controlling processes securely and efficiently, protecting individuals from accidents and preventing damage to the environment.

We have extensive experience in a wide range of industries and understand their processes and requirements. With intelligent sensors, we can deliver exactly what our customers need. In application centers in Europe, Asia and North America, system solutions are tested and optimized in accordance with customer specifications. All this makes us a reliable supplier and development partner.

Comprehensive services complete our offering: SICK LifeTime Services provide support throughout the machine life cycle and ensure safety and productivity.

For us, that is “Sensor Intelligence.”

WORLDWIDE PRESENCE:

Contacts and other locations –www.sick.com