



AOS104

AOS LiDAR

OBJECT DETECTION SYSTEMS

SICK
Sensor Intelligence.



Ordering information

Control configuration	Number of sensors	Max. range with 10 % reflectivity	Items supplied	Type	Part no.
Area monitoring and collision avoidance	4	18 m	LMS111-10100S01 (4 x) Flexi Soft main module FX3-CPU000000 Flexi Soft system plug FX3-MPL000001 Flexi Soft I/O module FX3-XTIO84002 (2 x) USB configuration cable USB stick with configuration files Connection box LMS1xx (4x) Mounting kit for LMS1xx (4x) Ethernet connection cable	AOS104	1066129

Included in delivery: Junction box (4), Mounting bracket (4), FX3-MPL000001 (1), LMS111-10100S01 (4), YM2D24-100P-N1MRJA4 (1), DSL-8U04G02M025KM1 (1), FX3-CPU000000 (1), FX3-XTIO84002 (2)

Other models and accessories → www.sick.com/AOS_LiDAR



Detailed technical data

Features

Sensor	LMS111-10100S01
Number of sensors	4
Aperture angle	270°
Max. range with 10 % reflectivity	18 m
Version	Standard

Mechanics/electronics

Housing dimensions (W x D x H)	105 mm x 102 mm x 162 mm (sensor) 67.5 mm x 96.5 mm x 120.6 mm (control with three modules, 22.5 mm each)
Weight	1.1 kg, Per LMS, without connection box
Supply voltage	24 V DC ¹⁾
Power consumption	8 W, Per LMS111 (+ heating 35 W, per LMS) 6.9 W, Flexi Soft with 2 x I/O module (without load)

¹⁾ Per LMS.

²⁾ Sensor.

³⁾ Control.

Fixing	Mounting kit (sensor), Mounting rail (control)
Enclosure rating	IP65/ IP67 ²⁾ IP20 ³⁾

¹⁾ Per LMS.

²⁾ Sensor.

³⁾ Control.

Performance

Number of laserscanners	4
Response time	240 ms

Interfaces

Number of safety inputs	✓ (16)
Number of safe outputs	✓ (8)
Configuration interface	Ethernet (sensor), USB (control)
Output data	Alarm via control signal Warning field intrusion, stop field intrusion System test error Contamination warning

Ambient data

Ambient operating temperature	-30 °C ... +50 °C, Sensor -25 °C ... +55 °C, Control
Ambient temperature, storage	-30 °C ... +70 °C ¹⁾ -25 °C ... +70 °C ²⁾
Ambient light immunity	40,000 lx
Vibration resistance	
Standard	IEC 60068-2-6:2007-12
Shock resistance	IEC 60068-2-27:2008-03

¹⁾ Sensor.

²⁾ Control.

General notes

Items supplied	LMS111-10100S01 (4 x) Flexi Soft main module FX3-CPU000000 Flexi Soft system plug FX3-MPL000001 Flexi Soft I/O module FX3-XTIO84002 (2 x) USB configuration cable USB stick with configuration files Connection box LMS1xx (4x) Mounting kit for LMS1xx (4x) Ethernet connection cable
Note on use	The AOS LiDAR object detection system is not a safety device for human protection and it therefore does not comply with any safety standards. For safety applications, please contact SICK AG.

Classifications

ECLASS 5.0	27281001
ECLASS 5.1.4	27280190
ECLASS 6.0	27280190
ECLASS 6.2	27280190
ECLASS 7.0	27280190

ECLASS 8.0	27280190
ECLASS 8.1	27280190
ECLASS 9.0	27280190
ECLASS 10.0	27280190
ECLASS 11.0	27280190
ECLASS 12.0	27280190
UNSPSC 16.0901	43211701

Dimensional drawing (Dimensions in mm (inch))

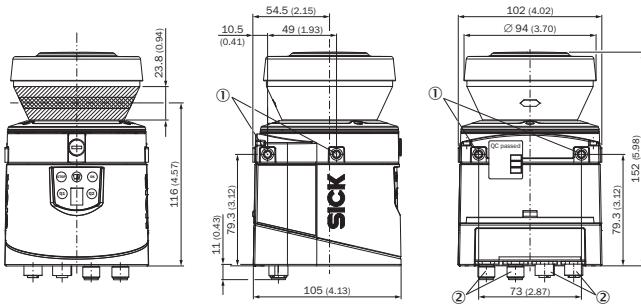

- ① Mounting hole M5 x 7.5
- ② Connector M12

FX3-XTIO, FX3-XTDI

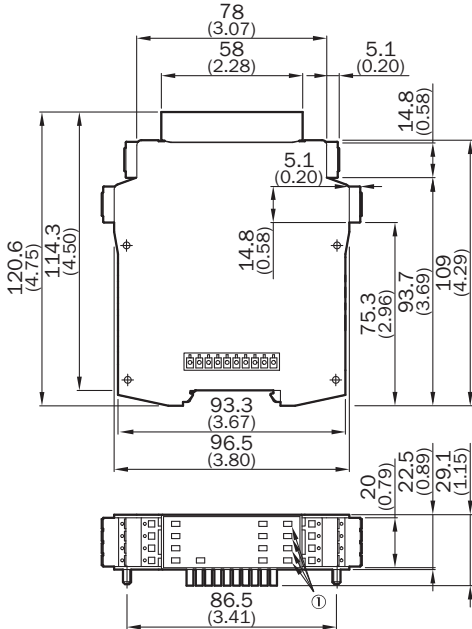

- ① Only valid for FX3-XTIO

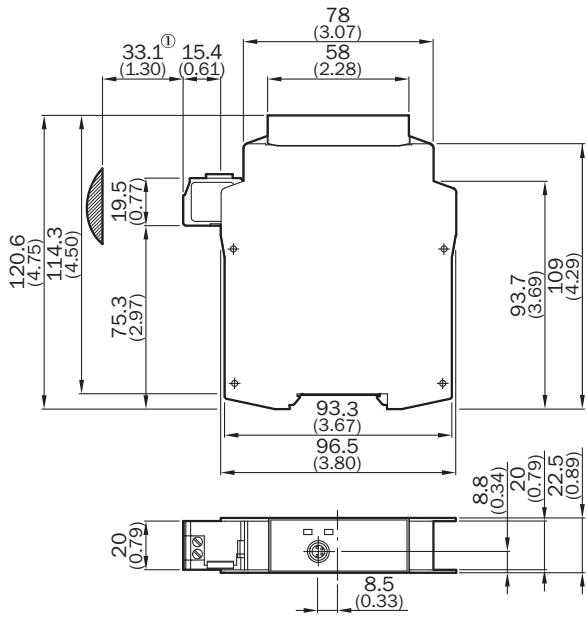

FX3-CPUO



① Approximate connector range

Recommended accessories

Other models and accessories → www.sick.com/AOS_LiDAR

	Brief description	Type	Part no.
Test and monitoring tools			
	Alignment aid for detecting the infrared light (wavelength 780 nm to 1050 nm) of SICK sensors	Alignment aid	2101720
Device protection (mechanical)			
	Weather hood, 190°	Weather protection cover 190°	2046459
①	If the sensor is mounted upside down, the label on top of the weather protection hood must be removed.		

	Brief description	Type	Part no.
 <p>① If the sensor is mounted upside down, the label on top of the weather protection hood must be removed.</p>	Weather protection hood 270°	Weather protection cover 270°	2046458

SICK AT A GLANCE

SICK is one of the leading manufacturers of intelligent sensors and sensor solutions for industrial applications. A unique range of products and services creates the perfect basis for controlling processes securely and efficiently, protecting individuals from accidents and preventing damage to the environment.

We have extensive experience in a wide range of industries and understand their processes and requirements. With intelligent sensors, we can deliver exactly what our customers need. In application centers in Europe, Asia and North America, system solutions are tested and optimized in accordance with customer specifications. All this makes us a reliable supplier and development partner.

Comprehensive services complete our offering: SICK LifeTime Services provide support throughout the machine life cycle and ensure safety and productivity.

For us, that is “Sensor Intelligence.”

WORLDWIDE PRESENCE:

Contacts and other locations –www.sick.com