



ELM35-0CA0A024A

ELS/ELM35

MOTOR FEEDBACK SYSTEMS

SICK
Sensor Intelligence.



Illustration may differ



Ordering information

Type	Part no.
ELM35-OCA0A024A	1133559

M3 mounting screws for stator coupling not included with delivery.

Other models and accessories → www.sick.com/ELS_ELM35

Detailed technical data

Features

Items supplied	M3 mounting screws for stator coupling not included with delivery.
-----------------------	--

Performance

Position	
Resolution per revolution	24 bit
System accuracy	$\pm 120''$, Typical, mounting tolerances acc. to mounting instruction ¹⁾
Signal noise (σ)	$10''$ ²⁾
Number of the absolute ascertainable revolutions	4,096
Available memory area	2,048 Byte

¹⁾ In accordance with DIN ISO 1319-1, position of the upper and lower error limit depends on the installation situation, specified value refers to a symmetrical position, i.e. deviation in upper and lower direction is the same.

²⁾ Repeatability standard deviation in accordance with DIN 1319-1:1995.

Interfaces

Code sequence	Increasing, when turning the shaft For clockwise rotation, looking in direction "A" (see dimensional drawing)
Communication interface	BiSS C

Electrical data

Connection type	Male connector, 6-pin ¹⁾
Recommended supply voltage	5 V ²⁾
Current consumption	Max. 150 mA

¹⁾ 4-wire: Communication interface RS-485 (BiSS C BP3), 2-wire: Power interface.

²⁾ ($\pm 10\%$) BiSS C.

Mechanical data

Shaft version	Blind hollow shaft
Shaft diameter	6 mm
Weight	≤ 0.1 kg

¹⁾ Temperature expansion, mechanical attachment.

Operating speed	6,000 min ⁻¹ , Continuous 7,500 min ⁻¹ , short-term
Angular acceleration	- 100,000 rad/s ²
Permissible movement static	± 0.5 mm axial ¹⁾ ± 0.1 mm radial
Permissible movement dynamic	± 0.05 mm radial

¹⁾ Temperature expansion, mechanical attachment.

Ambient data

Operating temperature range	-20 °C ... +105 °C
Storage temperature range	-20 °C ... +105 °C, without package
Relative humidity/condensation	90 %, Condensation not permitted
Resistance to shocks	100 g, 6 ms (EN 60068-2-27)
Frequency range of resistance to vibrations	20 g, 5 Hz ... 2,000 Hz (EN 60068-2-6)
EMC	According to EN 61000-6-2: 2016, EN 61000-6-4: 2006, IEC 6100-6-7: 2014
Enclosure rating	IP20 (IEC 60529-1)

Classifications

ECLASS 5.0	27270590
ECLASS 5.1.4	27270590
ECLASS 6.0	27270590
ECLASS 6.2	27270590
ECLASS 7.0	27270590
ECLASS 8.0	27270590
ECLASS 8.1	27270590
ECLASS 9.0	27270590
ECLASS 10.0	27273805
ECLASS 11.0	27273901
ECLASS 12.0	27273901
ETIM 5.0	EC001486
ETIM 6.0	EC001486
ETIM 7.0	EC001486
ETIM 8.0	EC001486
UNSPSC 16.0901	41112113

Dimensional drawing (Dimensions in mm (inch))

Blind hollow shaft

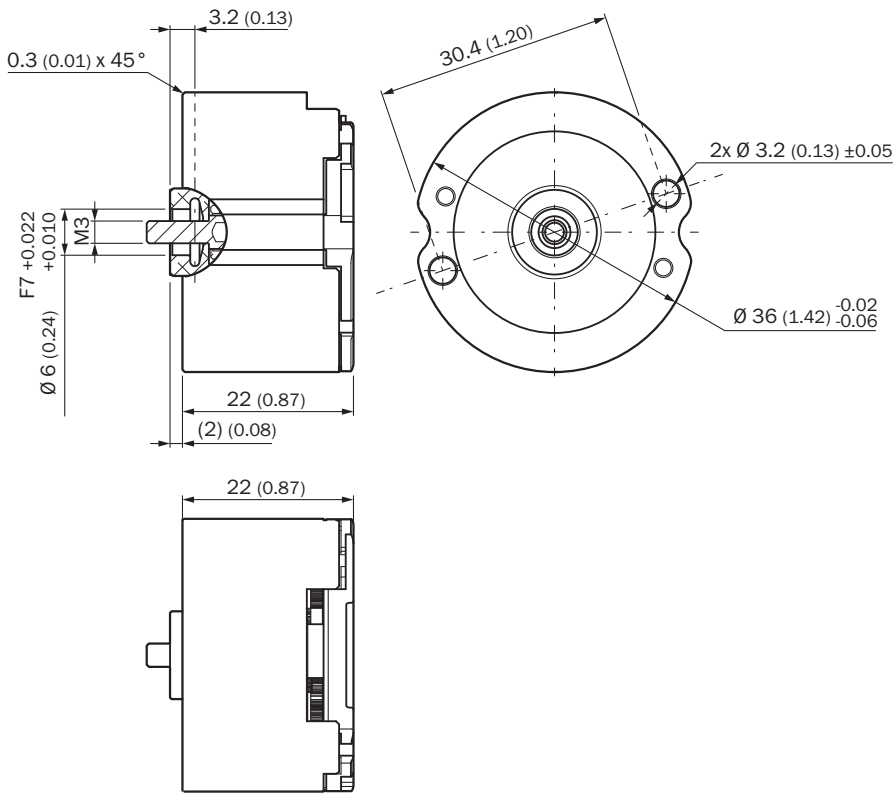

Connecting cable

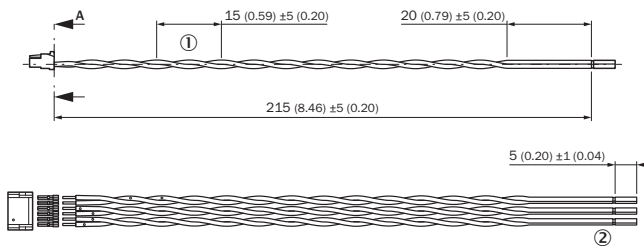

- ① Lay length
- ② Semi-stripped

Attachment specifications

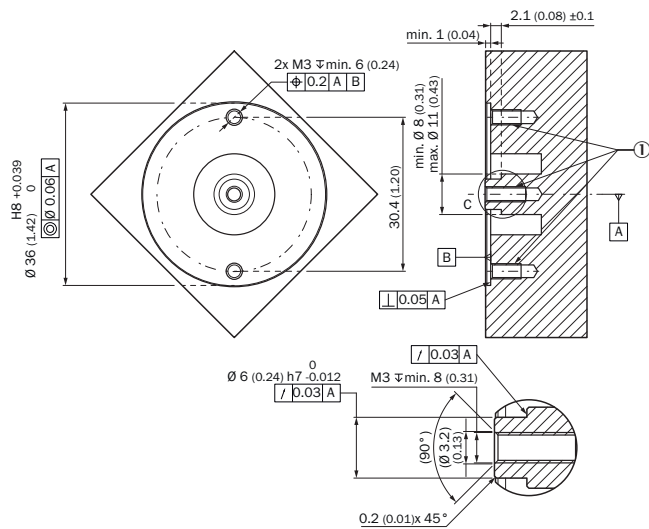

① 3 x M3 drill holes, screw with hex key size, s = 2.5 mm

PIN assignment

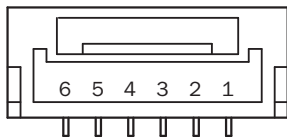

PIN	Signal	Explanation	
1	U _S	Supply voltage range for the encoder (is between +4.5 V DC and +5.5 V DC)	Pair
2	GND	Ground connection of the sensor	
3	Tx- / SL-	Slave data output, minus	Pair
4	Tx+ / SL+	Slave data output, plus	
5	Rx- / MA-	Master clock input, minus	Pair
6	Rx+ / MA+	Master clock input, plus	

SICK AT A GLANCE

SICK is one of the leading manufacturers of intelligent sensors and sensor solutions for industrial applications. A unique range of products and services creates the perfect basis for controlling processes securely and efficiently, protecting individuals from accidents and preventing damage to the environment.

We have extensive experience in a wide range of industries and understand their processes and requirements. With intelligent sensors, we can deliver exactly what our customers need. In application centers in Europe, Asia and North America, system solutions are tested and optimized in accordance with customer specifications. All this makes us a reliable supplier and development partner.

Comprehensive services complete our offering: SICK LifeTime Services provide support throughout the machine life cycle and ensure safety and productivity.

For us, that is “Sensor Intelligence.”

WORLDWIDE PRESENCE:

Contacts and other locations –www.sick.com