



FCA-A1Z2A1AZ

**SICK**  
Sensor Intelligence.



## Ordering information

Type	Part no.
FCA-A1Z2A1AZ	6073035

Other models and accessories → [www.sick.com/](http://www.sick.com/)



## Detailed technical data

### Technical specifications

<b>Accessory family</b>	Connection modules
<b>Connection type head A</b>	Male connectors and female connectors, M8, 4-pin, straight
<b>Connection type head B</b>	Female connector, M12, 4-pin, straight
<b>Locking plug connector</b>	Screw connection
<b>Signal type</b>	IO-Link, CANopen, RS-485
<b>Number of slots</b>	1
<b>Connecting cable</b>	0.5 m, for details see dimensional drawings, PVC
<b>Cable material</b>	PVC
<b>Cable color</b>	Black
<b>Housing material</b>	ABS (plastic)
<b>Housing color</b>	Black
<b>Tightening torque</b>	0.5 Nm
<b>Overvoltage category</b>	III
<b>Operating temperature</b>	-25 °C ... +55 °C, Operation -40 °C ... +80 °C, Storage
<b>Dimensions (W x H x L)</b>	37.4 mm x 13 mm x 60.4 mm
<b>Description</b>	FlexChain Adapter

### Classifications

<b>ECLASS 5.0</b>	19030312
<b>ECLASS 5.1.4</b>	19030312
<b>ECLASS 6.0</b>	27060304
<b>ECLASS 6.2</b>	27060304
<b>ECLASS 7.0</b>	27060304
<b>ECLASS 8.0</b>	27060304
<b>ECLASS 8.1</b>	27060304
<b>ECLASS 9.0</b>	27060304
<b>ECLASS 10.0</b>	27060304
<b>ECLASS 11.0</b>	27060304
<b>ETIM 5.0</b>	EC000830
<b>ETIM 6.0</b>	EC000830

<b>ETIM 7.0</b>	EC003249
<b>ETIM 8.0</b>	EC003249
<b>UNSPSC 16.0901</b>	26121604

Dimensional drawing (Dimensions in mm (inch))

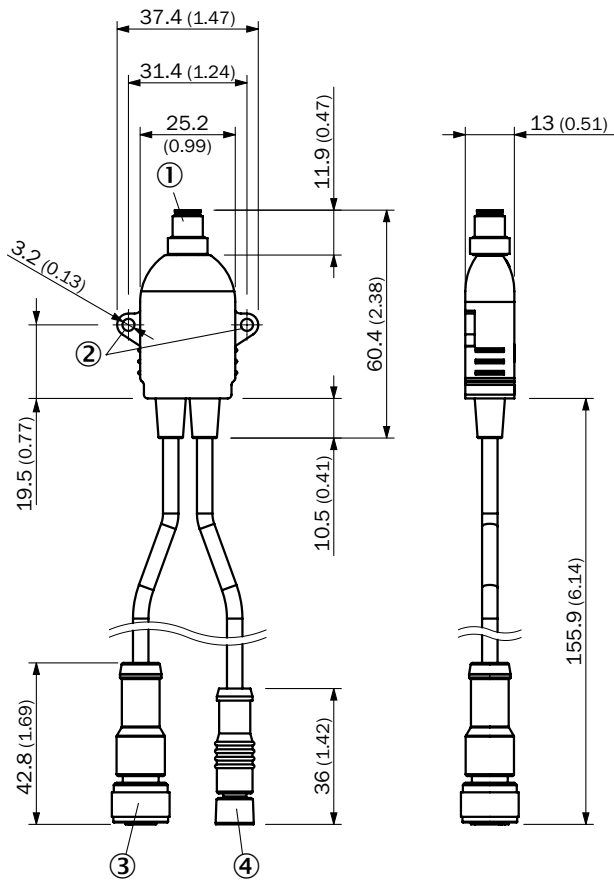

- ① Male connector M8, 4-pin
- ② Mounting hole, Ø 3.2 mm
- ③ Cable with female connector, M12, 4-pin
- ④ Cable with female connector, M8, 4-pin

## SICK AT A GLANCE

SICK is one of the leading manufacturers of intelligent sensors and sensor solutions for industrial applications. A unique range of products and services creates the perfect basis for controlling processes securely and efficiently, protecting individuals from accidents and preventing damage to the environment.

We have extensive experience in a wide range of industries and understand their processes and requirements. With intelligent sensors, we can deliver exactly what our customers need. In application centers in Europe, Asia and North America, system solutions are tested and optimized in accordance with customer specifications. All this makes us a reliable supplier and development partner.

Comprehensive services complete our offering: SICK LifeTime Services provide support throughout the machine life cycle and ensure safety and productivity.

For us, that is “Sensor Intelligence.”

## WORLDWIDE PRESENCE:

Contacts and other locations –[www.sick.com](http://www.sick.com)