



LBC621-17RB

Label Checker

2D MACHINE VISION

SICK
Sensor Intelligence.



Illustration may differ

Ordering information

Sensor	Type	Part no.
CMOS matrix sensor, grayscale values 1.3 Mpixel 1,280 px 1,024 px	LBC621-17RB	1115469

Other models and accessories → www.sick.com/Label_Checker



Detailed technical data

Features

Technology	2D snapshot
Light source	<ul style="list-style-type: none"> Internal lighting LED, visible red light, 617 nm, ± 15 nm Internal lighting LED, visible blue light, 470 nm, ± 15 nm Feedback spot LED, visible green light, 525 nm, ± 15 nm Adjustment aid Laser, visible red light, 630 nm ... 680 nm
Laser class	1, complies with 21 CFR 1040.10 except for the conformance according to "Laser Notice No. 50" from June 24, 2007 (IEC 60825-1:2014, EN 60825-1:2014)
Focus	Adjustable focus (electric)
Sensor	CMOS matrix sensor, grayscale values, 1.3 Mpixel, 1,280 px, 1,024 px
Spectral range	Approx. 400 nm ... 900 nm
Focal length	17.1 mm

Mechanics/electronics

Dimensions, system (L x W x H)	71 mm x 43 mm x 35.6 mm
Enclosure rating	IP65
Protection class	III
Power consumption	Typ. 4 W
Housing material	Aluminum die cast
Output current	≤ 100 mA
Connections	1 x M12, 17-pin male connector (serial, I/Os, voltage supply) 1 x M12, 4-pin female connector (Ethernet)
Supply voltage	12 V DC ... 24 V DC, ± 20 %
Window material	PMMA
Weight	170 g

Performance

Bar code types	2/5 Industrial Interleaved 2 of 5
-----------------------	--------------------------------------

	Codabar Code 39 Code 93 Code 128 EAN-8 EAN13 Pharmacode GS1-128 / EAN 128 Code 32 UPC-A UPC-E GS1, various types MSI
2D code types	Data Matrix ECC200 QR code Micro QR code PDF417 Aztec
OCR/OCV fonts	Universal, industrial, document, DotPrint, pharma, OCR-A, OCR-B, Arabic numbers
Optical format	1/1.8"
Maximum encoder frequency	300 Hz

Interfaces

Ethernet	✓, TCP/IP
Function	EtherNet/IP UDP PROFINET
Data transmission rate	10/100 MBit/s
Protocol	FTP HTTP
Operator interface	Web server
Optical indicators	5 x status display, 5 x LED bar graph, 1 green/red feedback spot
Acoustic indicators	Beeper

Ambient data

Ambient temperature, operation	-20 °C ... +70 °C, permissible relative humidity: 0% ... 90% (non-condensing)
Ambient temperature, storage	-20 °C ... +70 °C ¹⁾
Shock load	EN 60068-2-27:2009-05
Vibration load	EN 60068-2-6:2008-02

¹⁾ Permissible relative humidity: 0% ... 90% (non-condensing).

General notes

Items supplied	InspectorP V2D621P-2MSFFB5 LabelChecker software
-----------------------	---

Classifications

ECLASS 5.0	27310205
ECLASS 5.1.4	27310205
ECLASS 6.0	27310205
ECLASS 6.2	27310205
ECLASS 7.0	27310205
ECLASS 8.0	27310205
ECLASS 8.1	27310205

ECLASS 9.0	27310205
ECLASS 10.0	27289090
ECLASS 11.0	27289090
ECLASS 12.0	27289090
ETIM 5.0	EC001820
ETIM 6.0	EC001820
ETIM 7.0	EC001820
ETIM 8.0	EC001820
UNSPSC 16.0901	43211731

Dimensional drawing (Dimensions in mm (inch))

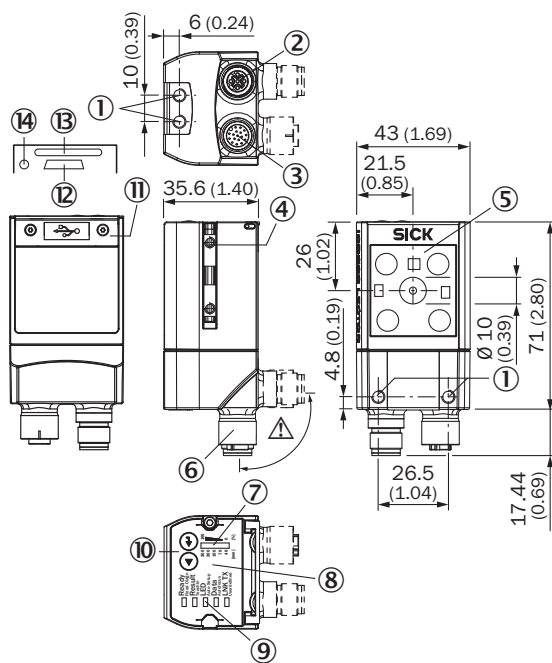

- ① M5 blind tapped holes, 5 mm deep (4 x), for mounting the sensor
- ② “Ethernet” connection, 4-pin M12 female connector, D-coded
- ③ “Power/Serial Data/CAN/I/O” connection, 17-pin M12 male connector, A-coded
- ④ Sliding nut M5, 5.5 mm deep (2 x), for mounting (as alternative)
- ⑤ Reading window with internal illumination LEDs (4 x)
- ⑥ Swivel connector unit
- ⑦ Bar graph
- ⑧ Beeper (under housing cover)
- ⑨ LEDs for status display (2 levels), 5 x
- ⑩ Function button (2 x)
- ⑪ Cover (flap)
- ⑫ “USB” connection (female connector, 5-pin, type Micro-B) interface for temporary use (service)
- ⑬ Slot for microSD memory card
- ⑭ LED for microSD memory card

Characteristic curve

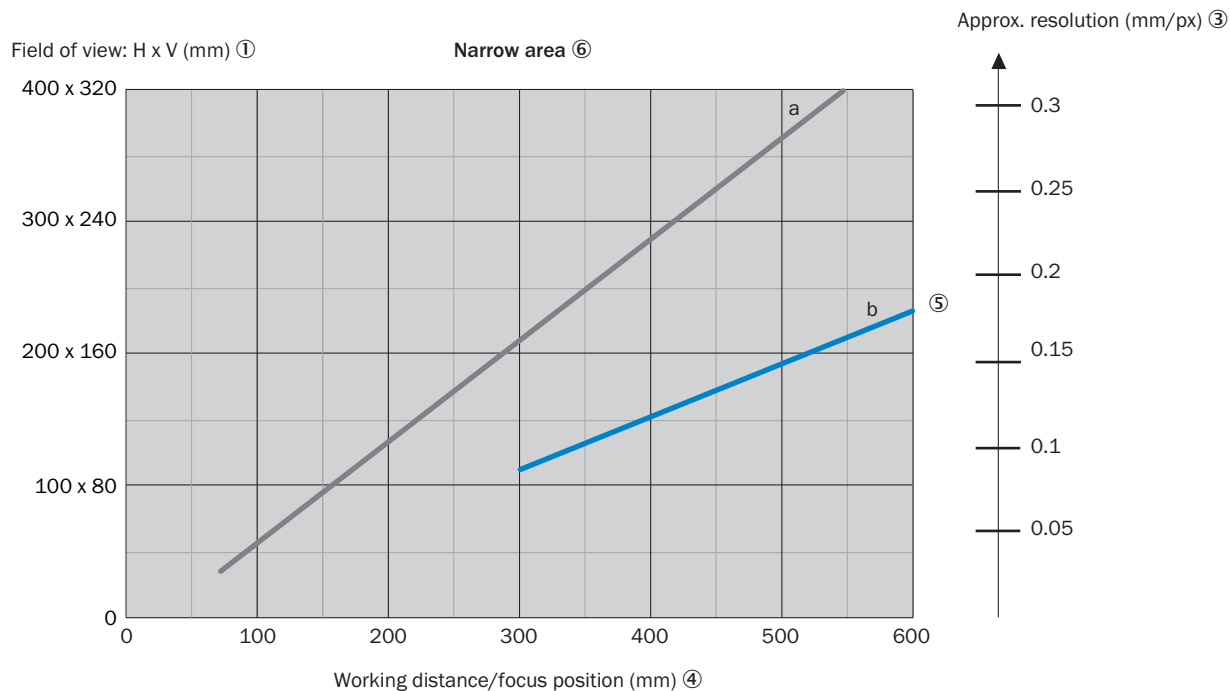
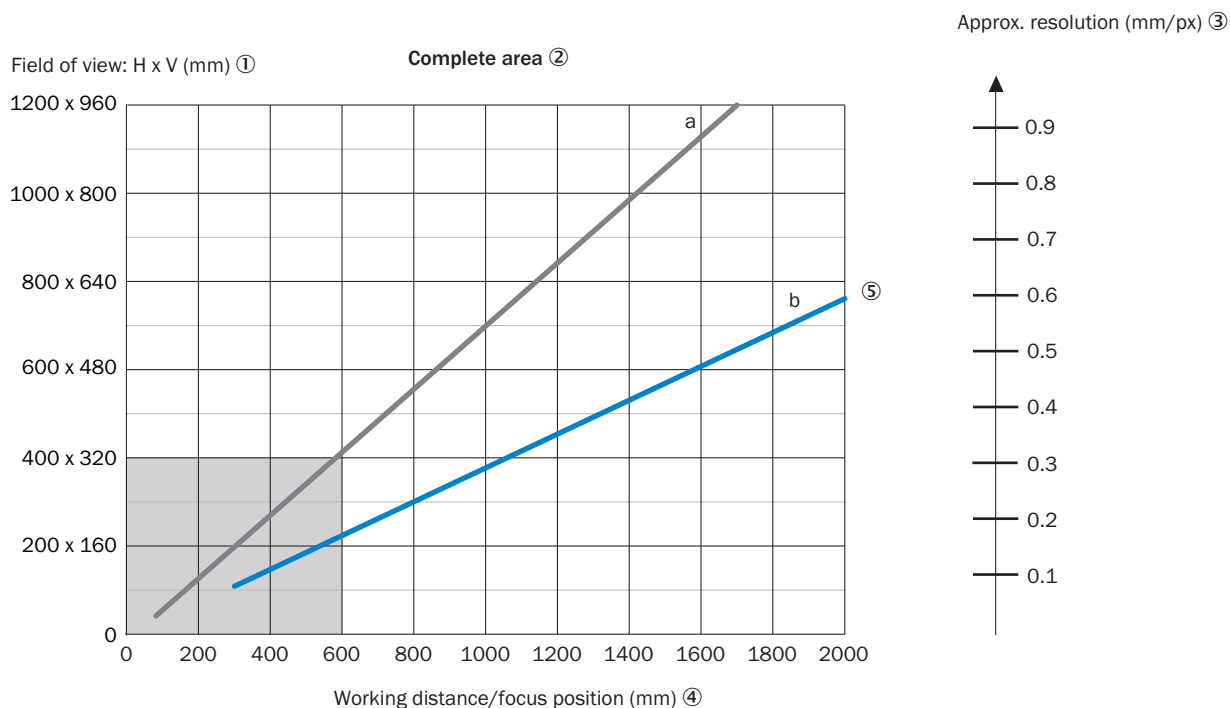

- a: f = 9.6 mm
- b: f = 17.1 mm



Take into account the following aspects when designing the application: the field of view geometry of the device, and the position of the field of view in the space in front of the device. Possible angles at which the objects can arise in relation to the device. For the planned working distance: resultant field of view length and width as well as the approximate resolution.

- ① Field of view: Horizontal x vertical in mm
- ② Complete area

- ③ Approximate resolution in mm/px
- ④ Working distance/Focus position in mm
- ⑤ Focal length of lens, here example for $f = 17.1$ mm
- ⑥ Narrow range

Recommended accessories

Other models and accessories → www.sick.com/Label_Checker

	Brief description	Type	Part no.
Mounting brackets and plates			
	Bracket with adapter board	Mounting bracket	2042902
Others			
	<ul style="list-style-type: none"> • Connection type head A: Female connector, M12, 17-pin, straight, A-coded • Connection type head B: Male connector, M12, 17-pin, straight, A-coded • Signal type: Power, serial, CAN, digital I/Os • Cable: 3 m, 17-wire • Description: Power, serial, CAN, digital I/Os, suitable for 2 A, shielded, to connection module CDB650 • Application: Drag chain operation 	YM2A8D-030XXF2A8D	6051194
	<ul style="list-style-type: none"> • Connection type head A: Male connector, M12, 4-pin, straight, D-coded • Connection type head B: Male connector, RJ45, 4-pin, straight • Signal type: Ethernet, PROFINET • Cable: 2 m, 4-wire, PUR, halogen-free • Description: Ethernet, PROFINET, shielded • Application: Drag chain operation, Zones with oils and lubricants 	YM2D24-020PN1MRJA4	2106182

SICK AT A GLANCE

SICK is one of the leading manufacturers of intelligent sensors and sensor solutions for industrial applications. A unique range of products and services creates the perfect basis for controlling processes securely and efficiently, protecting individuals from accidents and preventing damage to the environment.

We have extensive experience in a wide range of industries and understand their processes and requirements. With intelligent sensors, we can deliver exactly what our customers need. In application centers in Europe, Asia and North America, system solutions are tested and optimized in accordance with customer specifications. All this makes us a reliable supplier and development partner.

Comprehensive services complete our offering: SICK LifeTime Services provide support throughout the machine life cycle and ensure safety and productivity.

For us, that is “Sensor Intelligence.”

WORLDWIDE PRESENCE:

Contacts and other locations –www.sick.com