



# LBC654

Label Checker

2D MACHINE VISION

**SICK**  
Sensor Intelligence.



Illustration may differ

### Ordering information

Sensor	Type	Part no.
CMOS matrix sensor, grayscale values 4.2 Mpixel 2,048 px 2,048 px	LBC654	1086947

Other models and accessories → [www.sick.com/Label\\_Checker](http://www.sick.com/Label_Checker)



### Detailed technical data

#### Features

<b>Technology</b>	2D snapshot
<b>Light source</b>	Illumination LEDs: (to be ordered separately as accessories) Laser alignment aid: visible red light ( $\lambda = 630 \text{ nm} \dots 680 \text{ nm}$ )
<b>Laser class</b>	1, complies with 21 CFR 1040.10 except for the conformance according to "Laser Notice No. 50" from June 24, 2007 (IEC 60825-1:2014, EN 60825-1:2014)
<b>Focus</b>	Adjustable focus (manually)
<b>Sensor</b>	CMOS matrix sensor, grayscale values, 4.2 Mpixel, 2,048 px, 2,048 px
<b>Spectral range</b>	Approx. 400 nm ... 900 nm
<b>Lens</b>	C-mount

#### Mechanics/electronics

<b>Dimensions, system (L x W x H)</b>	142 mm x 90 mm x 46 mm (Housing only, without lens and optics protection hood)
<b>Enclosure rating</b>	IP65 (EN 60529 (1991-10), EN 60529/A2 (2002-02))
<b>Protection class</b>	III (EN 60950-1 (2014-08))
<b>Power consumption</b>	Typ. 10 W, $\pm 20 \%$
<b>Housing material</b>	Aluminum die cast
<b>Output current</b>	$\leq 100 \text{ mA}$
<b>Connections</b>	1 x M12, 17-pin male connector (serial, I/Os, voltage supply) 1 x M8, 4-pin female connector (USB, not used) 2 x M12, 8-pin female connector (Gigabit Ethernet, only one connection used)
<b>Supply voltage</b>	24 V DC, $\pm 20 \%$
<b>Window material</b>	Glass
<b>Weight</b>	635 g

#### Performance

<b>Bar code types</b>	2/5 Industrial Interleaved 2 of 5 Codabar Code 39 Code 93
-----------------------	---

	Code 128 EAN-8 EAN13 Pharmacode
<b>2D code types</b>	Data Matrix ECC200 QR code Micro QR code PDF417 Aztec
<b>OCR/OCV fonts</b>	Universal, industrial, document, DotPrint, pharma, OCR-A, OCR-B, Arabic numbers
<b>Optical format</b>	1"
<b>Maximum encoder frequency</b>	1 kHz

## Interfaces

<b>Ethernet</b>	✓, TCP/IP
Function	EtherNet/IP UDP / PROFINET FTP HTTP
Data transmission rate	10/100/1,000 Mbit/s
<b>Operator interface</b>	Web server
<b>Optical indicators</b>	10 x status display, 10 x LED bar graph, 1 green feedback spot
<b>Data storage and retrieval</b>	Image and data logging via microSD memory card and external FTP
<b>Acoustic indicators</b>	Beeper

## Ambient data

<b>Ambient temperature, operation</b>	-20 °C ... +70 °C, permissible relative humidity: 0% ... 90% (non-condensing)
<b>Ambient temperature, storage</b>	-20 °C ... +70 °C <sup>1)</sup>
<b>Shock load</b>	EN 60068-2-27:2009-05
<b>Vibration load</b>	EN 60068-2-6:2008-02

<sup>1)</sup> Permissible relative humidity: 0% ... 90% (non-condensing).

## General notes

<b>Items supplied</b>	InspectorP V2D654P LabelChecker software
-----------------------	---

## Classifications

<b>ECLASS 5.0</b>	27310205
<b>ECLASS 5.1.4</b>	27310205
<b>ECLASS 6.0</b>	27310205
<b>ECLASS 6.2</b>	27310205
<b>ECLASS 7.0</b>	27310205
<b>ECLASS 8.0</b>	27310205
<b>ECLASS 8.1</b>	27310205
<b>ECLASS 9.0</b>	27310205
<b>ECLASS 10.0</b>	27289090
<b>ECLASS 11.0</b>	27289090
<b>ECLASS 12.0</b>	27289090
<b>ETIM 5.0</b>	EC001820

<b>ETIM 6.0</b>	EC001820
<b>ETIM 7.0</b>	EC001820
<b>ETIM 8.0</b>	EC001820
<b>UNSPSC 16.0901</b>	43211731

### Dimensional drawing (Dimensions in mm (inch))

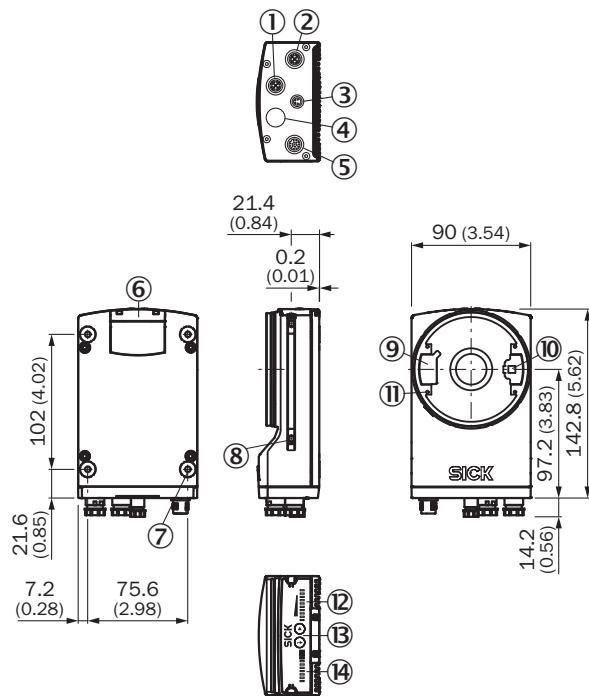

- ① "Ethernet" P1 connection
- ② P3 connection "Ethernet"
- ③ X2 "USB" connection or "trigger external lighting", depending on type
- ④ P2 connection "CAN OUT", depending on type
- ⑤ X1 "Power/Serial Data/CAN/I/O" connection or "CAN IN", depending on type
- ⑥ Cover for the microSD memory card
- ⑦ M5 blind tapped holes, 5 mm deep (4 x), for mounting the sensor
- ⑧ Sliding nut M5, 5.5 mm deep (2 x), for mounting (as alternative)
- ⑨ Plug connector for connecting the integrated lighting
- ⑩ Laser alignment aid exit
- ⑪ 2.5 mm blind tapped holes (4 x) for mounting the spacers for the integrable illumination
- ⑫ Bar graph display
- ⑬ Function button (2 x)
- ⑭ LED for status display (2 levels), 10 x

## Characteristic curve

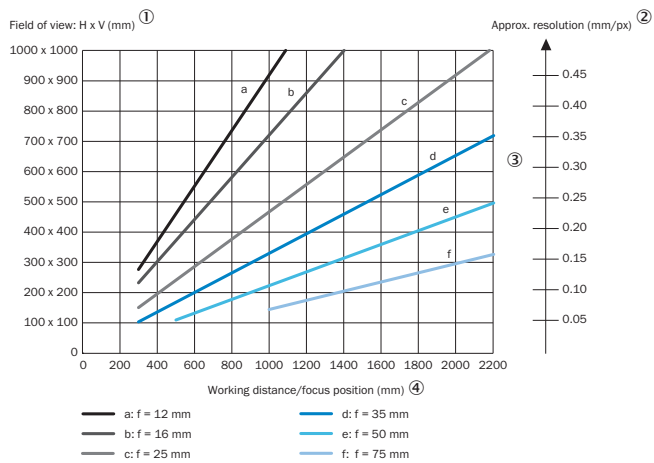

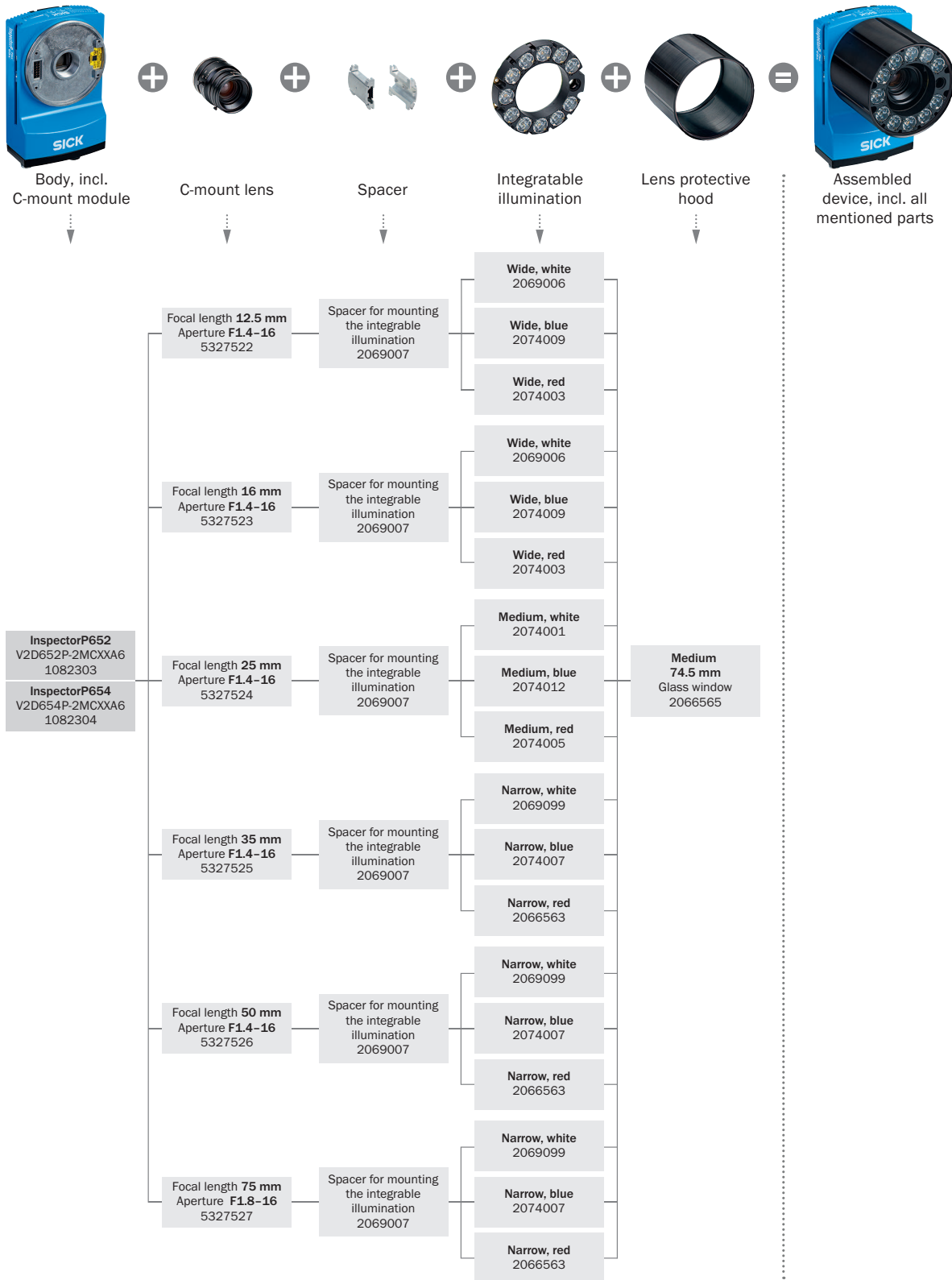

- ① Field of view: Horizontal x vertical in mm
- ② Approximate resolution in mm/px
- ③ Lens focal length
- ④ Working distance/Focus position in mm

### Selection Guide

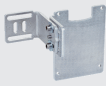

## Recommended accessories

Other models and accessories → [www.sick.com/Label\\_Checker](http://www.sick.com/Label_Checker)

	Brief description	Type	Part no.
Lenses and accessories			
	Optics kit 03 incl. lens with focal distance 25 mm, white illumination, spacer and optics protective hood	Optics kit 03	1064793
Mounting brackets and plates			
	Mounting bracket kit comprising mounting bracket, cooling plate and screws, including angle indicator for adjusting the tilt angle	Mounting bracket kit	2069171
Other mounting accessories			
	Sliding nut, M5, short	Sliding nut	5324896
Others			
	<ul style="list-style-type: none"> <li>• <b>Connection type head A:</b> Female connector, M12, 17-pin, straight, A-coded</li> <li>• <b>Connection type head B:</b> Flying leads</li> <li>• <b>Signal type:</b> Power, serial, CAN, digital I/Os</li> <li>• <b>Cable:</b> 3 m, 17-wire, stripped, PE-X</li> <li>• <b>Description:</b> Power, serial, CAN, digital I/Os, suitable for 2 A, Changed color coding of the flying leads, shielded</li> <li>• <b>Connection systems:</b> Flying leads</li> <li>• <b>Application:</b> Drag chain operation</li> </ul>	YF2ASD-030XXXXLECX	2070425

## SICK AT A GLANCE

SICK is one of the leading manufacturers of intelligent sensors and sensor solutions for industrial applications. A unique range of products and services creates the perfect basis for controlling processes securely and efficiently, protecting individuals from accidents and preventing damage to the environment.

We have extensive experience in a wide range of industries and understand their processes and requirements. With intelligent sensors, we can deliver exactly what our customers need. In application centers in Europe, Asia and North America, system solutions are tested and optimized in accordance with customer specifications. All this makes us a reliable supplier and development partner.

Comprehensive services complete our offering: SICK LifeTime Services provide support throughout the machine life cycle and ensure safety and productivity.

For us, that is “Sensor Intelligence.”

## WORLDWIDE PRESENCE:

Contacts and other locations –[www.sick.com](http://www.sick.com)