



LBV311-XXAGCNCMX

LBV301

LEVEL SENSORS

SICK
Sensor Intelligence.



Illustration may differ



Ordering information

Type	Part no.
LBV311-XXAGCNKMX	6044866

Other models and accessories → www.sick.com/LBV301

Detailed technical data

Features

Medium	Bulk solids
Measurement	Switch
Probe length	160 mm
Process pressure	-1 bar ... 16 bar
Process temperature	-50 °C ... +150 °C
Fill material density	≥ 0.02 g/cm ³

Performance

Accuracy of sensor element	± 10 mm
Reproducibility	≤ 5 mm
Response time	500 ms when covered / 1,000 ms when uncovered
MTBF	4,17*10 ⁶ h

Electronics

Power consumption	1 mA / 2,5 mA
Initialization time	< 2 s
VDE protection class 2	✓
Connection type	M20 x 1.5
Output signal	NAMUR signal
Supply voltage	NAMUR signal: 4.5 V DC ... 12 V DC
Hysteresis	10 mm
Output current	1 mA / 2,5 mA
Enclosure rating	IP66 / IP67

Mechanics

Process connection	G 1 A
Housing material	Plastic
Sensor material	Stainless steel 316L, 318S

Ambient data

Ambient operating temperature	-40 °C ... +70 °C
--------------------------------------	-------------------

Ambient temperature, storage	-40 °C ... +80 °C
-------------------------------------	-------------------

Classifications

ECLASS 5.0	27273202
ECLASS 5.1.4	27273202
ECLASS 6.0	27273202
ECLASS 6.2	27273202
ECLASS 7.0	27273202
ECLASS 8.0	27273202
ECLASS 8.1	27273202
ECLASS 9.0	27273202
ECLASS 10.0	27273202
ECLASS 11.0	27273202
ECLASS 12.0	27273106
ETIM 5.0	EC002654
ETIM 6.0	EC002654
ETIM 7.0	EC002654
ETIM 8.0	EC002654
UNSPSC 16.0901	41111938

Type code

LBV311 type code

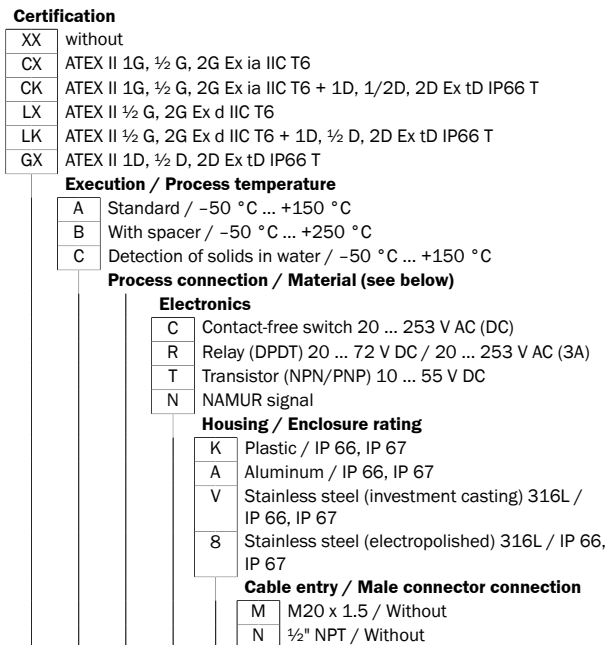

LBV311 - [] [] [] [] [] [] [] [] [] [] [] X

Not all variants of the type code can be combined! Not all available variants are shown.

Process connection / Material

GC	Thread G 1, DIN 3852-A, PN 16 / 316L
GR	Thread G 1, DIN 3852-A, PN 16 / 316L, Ra < 0.8 µm
GG	Thread G 1 ½, DIN 3852-A, PN 16 / 316L
GP	Thread G 1 ½, DIN 3852-A, PN 16 / 316L, Ra < 0.8 µm
NC	Thread 1" NPT, ASME B1.20.1, PN 16 / 316L
NR	Thread 1" NPT, ASME B1.20.1, PN 16 / 316L, Ra < 0.8 µm
NH	Thread 1 ¼" NPT, ASME B1.20.1, PN 16 / 316L
NI	Thread 1 ¼" NPT, ASME B1.20.1, PN 16 / 316L, Ra < 0.8 µm
NG	Thread 1 ½" NPT, ASME B1.20.1, PN 16 / 316L
NP	Thread 1 ½" NPT, ASME B1.20.1, PN 16 / 316L, Ra < 0.8 µm
CT	Tri-Clamp 1 ½" / 316L, Ra < 0.8 µm
CV	Tri-Clamp 2" / 316L, Ra < 0.8 µm
CQ	Tri-Clamp 2 ½" / 316L, Ra < 0.8 µm
CM	Tri-Clamp 3 ½" / 316L, Ra < 0.8 µm
RP	Pipe connection DN 40, PN 40, DIN 11851 / 316L, Ra < 0.8 µm
RF	Pipe connection DN 40, PN 40, DIN 11864-1, form A / 316L, Ra < 0.8 µm
RH	Pipe connection DN 65, PN 25, DIN 11851 / 316L, Ra < 0.8 µm
TV	Tuchenhagen Varivent DN 32.1 ½", PN 25 / 316L, Ra < 0.8 µm
C2	Bundle clamp DN 40, PN 40, DIN 11864-3, form A / 316L, Ra < 0.8 µm
BF	Flange DN 32, PN 40, form C, DIN 2501 / 316L
DF	Flange DN 40, PN 40, form C, DIN 2501 / 316L
AU	Flange DN50 10K RF, JIS / 316L
HU	Flange DN65 10K RF, JIS / 316L

EF	Flange DN 50, PN 40, form C, DIN 2501 / 316L
4F	Flange DN 65, PN 16, form C, DIN 2501 / 316L
No error	Flange DN 80, PN 40, form C, DIN 2501 / 316L
ZF	Flange DN 100, PN 6, form C, DIN 2501 / 316L
MF	Flange DN 100, PN 16, form C, DIN 2501 / 316L
OF	Flange DN 100, PN 40, form C, DIN 2501 / 316L
3F	Flange DN 125, PN 6, form C, DIN 2501 / 316L
QF	Flange DN 150, PN 16, form C, DIN 2501 / 316L
2F	Flange DN 200, PN 10, form C, DIN 2501 / 316L
EB	Flange DN 50, PN 40, EN 1092-1, form B1 / 316L
DA	Flange 1 ½" 150 lb RF, ANSI B16.5 / 316L
EA	Flange 1 ½" 300 lb RF, ANSI B16.5 / 316L
HA	Flange 2" 150 lb RF, ANSI B16.5 / 316L
IA	Flange 2" 300 lb RF, ANSI B16.5 / 316L
OA	Flange 3" 150 lb RF, ANSI B16.5 / 316L
OE	Flange 3" 150 lb FF, ANSI B16.5 / 316L
PA	Flange 3" 300 lb RF, ANSI B16.5 / 316L
PE	Flange 3" 300 lb FF, ANSI B16.5 / 316L
JA	Flange 3 ½" 150 lb RF, ANSI B16.5 / 316L
SA	Flange 4" 150 lb RF, ANSI B16.5 / 316L
UA	Flange 4" 300 lb RF, ANSI B16.5 / 316L
BU	Flange DN80 10K RF, JIS / 316L
CU	Flange DN100 10K RF, JIS / 316L

Dimensional drawing (Dimensions in mm (inch))

LBV311 threaded version G 1 ½ A

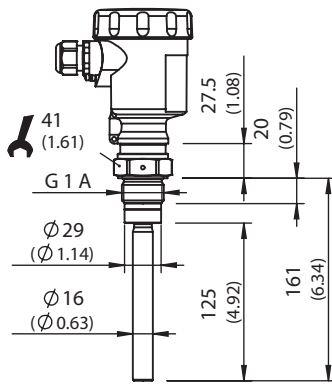

All dimensions in mm (inch)

LBV311 threaded version G 1 A

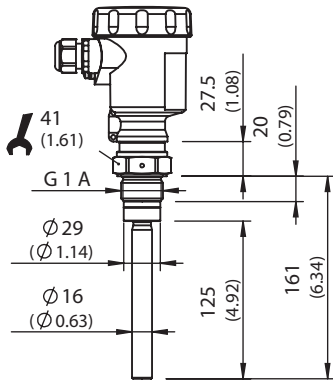

All dimensions in mm (inch)

LBV311 temperature adapter -50 °C ... +250 °C



All dimensions in mm (inch)

LBV311 threaded version Tri-Clamp

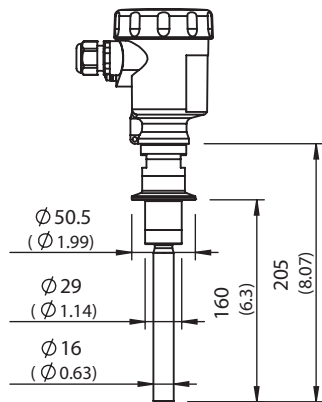

All dimensions in mm (inch)

Connection diagram

Namur connection diagram

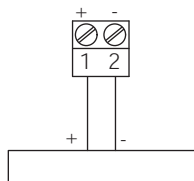

Instruction for installation

Horizontal mounting

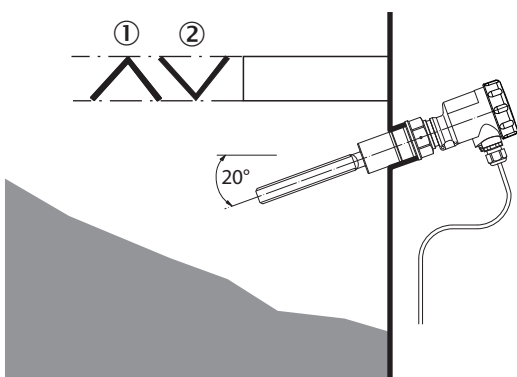

- ① Protective sheet
- ② Concave protective sheet for abrasive solids

Characteristic curve

Ambient temperature - process temperature

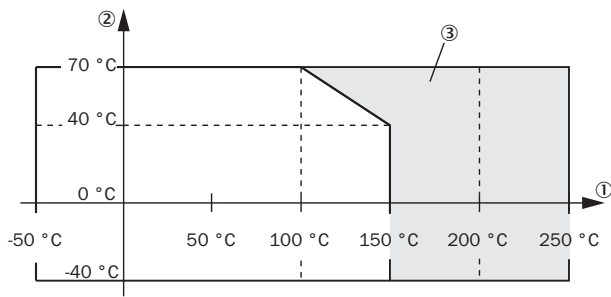

- ① Process temperature in °C (°F)
- ② Ambient temperature in °C (°F)
- ③ Temperature range with temperature adapter

SICK AT A GLANCE

SICK is one of the leading manufacturers of intelligent sensors and sensor solutions for industrial applications. A unique range of products and services creates the perfect basis for controlling processes securely and efficiently, protecting individuals from accidents and preventing damage to the environment.

We have extensive experience in a wide range of industries and understand their processes and requirements. With intelligent sensors, we can deliver exactly what our customers need. In application centers in Europe, Asia and North America, system solutions are tested and optimized in accordance with customer specifications. All this makes us a reliable supplier and development partner.

Comprehensive services complete our offering: SICK LifeTime Services provide support throughout the machine life cycle and ensure safety and productivity.

For us, that is “Sensor Intelligence.”

WORLDWIDE PRESENCE:

Contacts and other locations –www.sick.com