

LL3-DR04

Fiber-optic cables

FIBERS

SICK
Sensor Intelligence.



Ordering information

Type	Part no.
LL3-DR04	5308081

Other models and accessories → www.sick.com/Fiber-optic_cables

Detailed technical data

Features

Device type	Fiber-optic cables
Functional principle	Proximity system
Fiber-optic head design	Smooth sleeve
Application	High flexible (static), Robotics (dynamic flexible)
Compatible fiber-optic amplifiers	WLL80, WLL180, GLL170(T)
Sensing range max.	320 mm (Sensing range of WLL80 at 8 ms)
Minimal object diameter	0.015 mm ¹⁾
Optical fiber head	
Angle of dispersion	60°
Integrated lens	No
Compatibility tip adapters	No
Optical fiber	
Compatibility with infrared light	No
Optical fiber cable can be shortened	✓
Adapter end sleeves required	No

¹⁾ Minimum detectable object was determined at optimum measuring distance and optimum setting.

Mechanics

Optical fiber head	
Light emission	Axial
Smooth sleeve diameter	1.5 mm
Optical fiber	
Fiber length	1,000 mm
Bending radius	4 mm
Dynamic flexibility (robotics)	Yes
Outside diameter, optical fiber cable connection	1.3 mm
Fiber arrangement	Multi-fiber
Core structure	S: 2 x Ø 0,25 mm R: 2 x Ø 0,25 mm ¹⁾ Multi-fiber
Material	
Optical fiber head	Stainless steel
Sheath	Polyethylen (PE)

¹⁾ C = Coaxial, S = Sender, E = Receiver.

	Fibers	Polymethylmethacrylat (PMMA)
Weight		8 g

¹⁾ C = Coaxial, S = Sender, E = Receiver.

Ambient data

Ambient operating temperature	-40 °C ... +70 °C
--------------------------------------	-------------------

Classifications

ECLASS 5.0	27270905
ECLASS 5.1.4	27270905
ECLASS 6.0	27270905
ECLASS 6.2	27270905
ECLASS 7.0	27270905
ECLASS 8.0	27270905
ECLASS 8.1	27270905
ECLASS 9.0	27270905
ECLASS 10.0	27270905
ECLASS 11.0	27270905
ECLASS 12.0	27270905
ETIM 5.0	EC002651
ETIM 6.0	EC002651
ETIM 7.0	EC002651
ETIM 8.0	EC002651
UNSPSC 16.0901	39121528

Sensing ranges with WLL80

Operating mode 16 µs	18 mm
Operating mode 70 µs	65 mm
Operating mode 250 µs	120 mm
Operating mode 500 µs	150 mm
Operating mode 1 ms	180 mm
Operating mode 2 ms	210 mm
Operating mode 8 ms	320 mm

Sensing ranges with WLL180T

Operating mode 16 µs	20 mm
Operating mode 70 µs	70 mm
Operating mode 250 µs	110 mm
Operating mode 2 ms	220 mm
Operating mode 8 ms	360 mm
Note	Sensing ranges related to fiber-optic sensors with type of light: visible red light

Sensing ranges with GLL170

Operating mode 250 µs	20 mm
------------------------------	-------

Sensing ranges with GLL170T

Operating mode 50 μs	30 mm
Operating mode 250 μs	60 mm

Dimensional drawing (Dimensions in mm (inch))

LL3-DR04

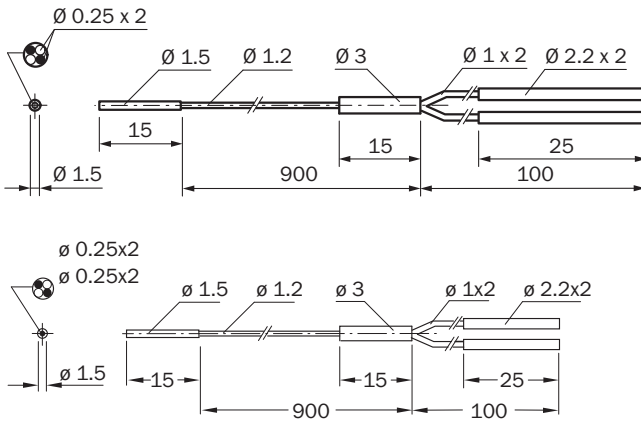

SICK AT A GLANCE

SICK is one of the leading manufacturers of intelligent sensors and sensor solutions for industrial applications. A unique range of products and services creates the perfect basis for controlling processes securely and efficiently, protecting individuals from accidents and preventing damage to the environment.

We have extensive experience in a wide range of industries and understand their processes and requirements. With intelligent sensors, we can deliver exactly what our customers need. In application centers in Europe, Asia and North America, system solutions are tested and optimized in accordance with customer specifications. All this makes us a reliable supplier and development partner.

Comprehensive services complete our offering: SICK LifeTime Services provide support throughout the machine life cycle and ensure safety and productivity.

For us, that is “Sensor Intelligence.”

WORLDWIDE PRESENCE:

Contacts and other locations –www.sick.com