



LRS4581R-230001

LRS4000

2D LIDAR SENSORS

SICK
Sensor Intelligence.



Ordering information

Type	Part no.
LRS4581R-230001	1098855

Other models and accessories → www.sick.com/LRS4000



Detailed technical data

Features

Application	Outdoor, Indoor
Light source	Infrared (886 nm)
Laser class	1, Complies with 21 CFR 1040.10 and 1040.11 except for conformance with IEC 60825-1 Ed.3., as described in "Laser Notice No. 56" dated May 8, 2019 (IEC 60825-1:2014, EN 60825-1:2014)
Aperture angle	Horizontal 360°
Scanning frequency	12.5 Hz 25 Hz
Angular resolution	Horizontal 0.02° 0.04° 0.06° 0.08° 0.1° 0.12° 0.24°
Heating	Self-heating
Working range	0.2 m ... 300 m
Scanning range	At 10% remission factor 80 m At 90% remission factor 250 m
Spot size	2.6 mrad x 0.4 mrad (Single spot) 2.6 mrad x 0.4 mrad (+ angular resolution for HDDM ⁺)
Amount of evaluated echoes	3

Mechanics/electronics

Connection type	3 x M12
Supply voltage	10 V DC ... 30 V DC
Power consumption	Typ. 13 W, Max. 20 W
Output current	≤ 0.25 A

Housing material	AlSi12
Housing color	Gray (RAL 7042)
Optical hood	Polycarbonat (PC)
Enclosure rating	IP65 (IEC 60529:1989+AMD1:1999+AMD2:2013) IP67 (IEC 60529:1989+AMD1:1999+AMD2:2013)
Protection class	III (IEC 61140:2016-11)
Electrical safety	IEC 61010-1:2010-06
Weight	1.7 kg
Dimensions (L x W x H)	151.9 mm x 150 mm x 126.7 mm

Performance

Scan/frame rate	37,500 measurement point/s ... 225,000 measurement point/s
Response time	≥ 40 ms
Detectable object shape	Almost any
Systematic error	± 15 mm
Statistical error	< 10 mm
Temperature drift	± 0.2 mm/K
Integrated application	Field evaluation Output of measurement data
Number of field sets	10 fields
Filter	Median filter Average filter

Interfaces

Ethernet	✓, TCP/IP, UDP/IP
Function	Data interface (read result output)
Data transmission rate	10/100 MBit/s
Digital inputs	6
Encoder inputs	2
Digital outputs	6
Optical indicators	LEDs
Configuration software	Web server

Ambient data

Object remission	2 % ... 1,000 % (Reflector)
Electromagnetic compatibility (EMC)	
Emitted radiation	Residential area (EN 61000-6-3:2007+AMD:A1:2011)
Electromagnetic immunity	Industrial environment (EN 61000-6-2:2005)
Vibration resistance	
Sine test	10 Hz ... 500 Hz, 5 g, 10 frequency cycles ¹⁾
Shock resistance	
	50 g, 11 ms, 6 shocks per axis ²⁾ 25 g, 6 ms, 1000 shocks per axis ²⁾
Ambient operating temperature	-30 °C ... +50 °C

¹⁾ EN 60068-2-6:2007.

²⁾ EN 60068-2-27:2008.

Storage temperature	-40 °C ... +75 °C
Permissible relative humidity	≤ 90 %, Non-condensing
Ambient light immunity	80 klx

¹⁾ EN 60068-2-6:2007.

²⁾ EN 60068-2-27:2008.

General notes

Note on use	The sensor does not constitute a safety component as defined by relevant legislation on machine safety.
--------------------	---

Classifications

ECLASS 5.0	27270990
ECLASS 5.1.4	27270990
ECLASS 6.0	27270913
ECLASS 6.2	27270913
ECLASS 7.0	27270913
ECLASS 8.0	27270913
ECLASS 8.1	27270913
ECLASS 9.0	27270913
ECLASS 10.0	27270913
ECLASS 11.0	27270913
ECLASS 12.0	27270913
ETIM 5.0	EC002550
ETIM 6.0	EC002550
ETIM 7.0	EC002550
ETIM 8.0	EC002550
UNSPSC 16.0901	41111615

Dimensional drawing (Dimensions in mm (inch))

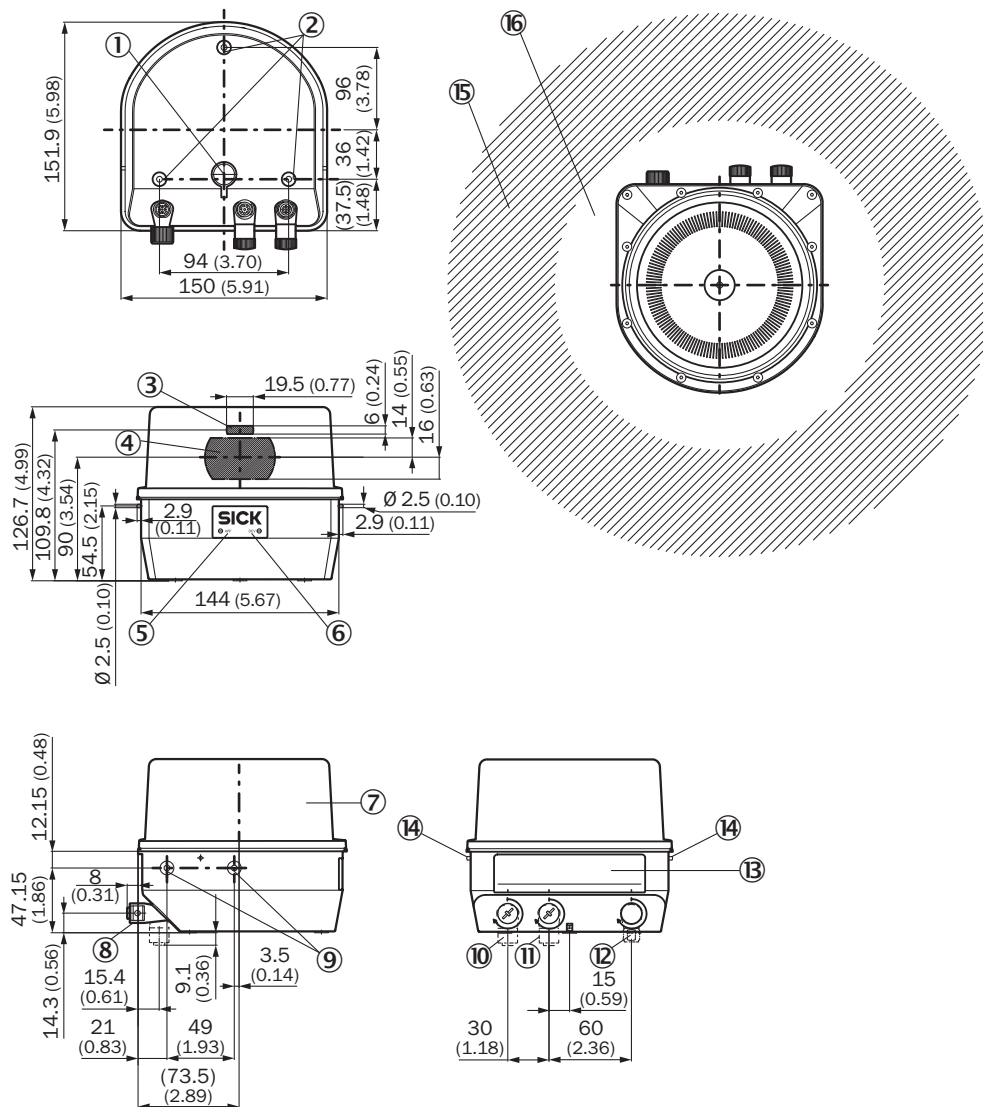

- ① Gore-Tex membrane
- ② Fixing hole M5 x 7.5 (3 x)
- ③ Sender
- ④ Receiver
- ⑤ LED APP
- ⑥ LED DEV
- ⑦ Optical hood
- ⑧ Rotatable connections (max. 270°)
- ⑨ Fixing hole M5 x 7.5 (2 x)
- ⑩ Ethernet connection
- ⑪ I/O connection
- ⑫ POWER connection
- ⑬ Type label
- ⑭ Locating pin for hooking into the bracket during mounting
- ⑮ Measuring range > 500 mm
- ⑯ Near range < 500 mm

Working range diagram

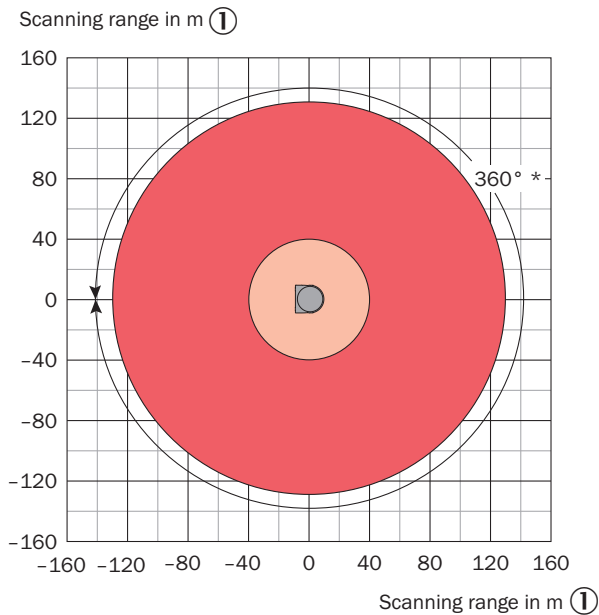

* With the angular resolution $0.020^\circ/12.5\text{ Hz}$ and $0.040^\circ/25\text{ Hz}$, the aperture angle is limited to 288° ②

■ Scanning range max. for objects up to 90 % Remission 130 m ③

■ Scanning range for objects up to 10 % Remission 40 m ④

① Scanning range in m



② The aperture angle is limited to 288° with angular resolution $0.020^\circ/12.5\text{ Hz}$ and $0.040^\circ/25\text{ Hz}$



③ Scanning range for objects with up to 90% remission factor, 130 m

④ Scanning range for objects with up to 10% remission factor, 40 m

Recommended accessories

Other models and accessories → www.sick.com/LRS4000

	Brief description	Type	Part no.
Terminal and alignment brackets			
	Easy Mount, X6CRNITI1810 (1.4541), Mounting kit 1a (2034324), 4 x M5 x 10 counter-sunk screws, stainless steel	Mounting kit 1a	2093194
Others			
	<ul style="list-style-type: none"> • Connection type head A: Female connector, M12, 5-pin, straight • Connection type head B: Flying leads • Signal type: Sensor/actuator cable • Cable: 10 m, 5-wire, PUR, halogen-free • Description: Sensor/actuator cable, shielded • Connection systems: Flying leads • Application: Uncontaminated zones, Zones with oils and lubricants, Robot, Drag chain operation 	YF2A65-100UE2XLEAX	2093090

	Brief description	Type	Part no.
	<ul style="list-style-type: none"> • Connection type head A: Male connector, M12, 4-pin, straight, D-coded • Connection type head B: Male connector, RJ45, 4-pin, straight • Signal type: Ethernet • Cable: 10 m, 4-wire, CAT5, CAT5e, PUR • Description: Ethernet, shielded • Application: Outdoor 	YM2D34-100PN4MRJA4	6054492
	<ul style="list-style-type: none"> • Connection type head A: Male connector, M12, 8-pin, straight • Connection type head B: Flying leads • Signal type: Sensor/actuator cable • Cable: 10 m, 8-wire, PUR, halogen-free • Description: Sensor/actuator cable, shielded • Connection systems: Flying leads • Application: Uncontaminated zones, Zones with oils and lubricants, Robot, Drag chain operation 	YM2A68-100UA6XLEAX	6054490
	<ul style="list-style-type: none"> • Connection type head A: Male connector, M12, 4-pin, straight, D-coded • Connection type head B: Male connector, RJ45, 4-pin, straight • Signal type: Ethernet • Cable: 30 m, 4-wire, CAT5, CAT5e, PUR • Description: Ethernet, shielded • Application: Outdoor 	YM2D34-300PN4MRJA4	2142315

Recommended services

Additional services → www.sick.com/LRS4000

	Type	Part no.
Extended warranty		
<ul style="list-style-type: none"> • Product area: Machine vision, LiDAR sensors, safety camera sensors, Safety laser scanners, Safety radar sensors, Radar sensors, Fixed mount barcode scanners, Image-based code readers, RFID, Mobile handheld scanners • Range of services: The services correspond to the scope of the statutory warranty (SICK General Terms of Delivery) • Duration: Five-year warranty from delivery date. 	Extended warranty for a total of five years from delivery date	1680671
Commissioning		
<ul style="list-style-type: none"> • Product area: 2D LiDAR sensors, 3D LiDAR sensors • Range of services: Inspection of connection, fine adjustment, configuration of monitored areas, configuration and optimization of parameters as well as tests, Setup of previously defined functions of basic settings, parameters of field application, filters for raw data output and product-specific configuration • Duration: Additional work will be invoiced separately 	Commissioning LiDAR sensors	1680672
Maintenance		
<ul style="list-style-type: none"> • Product area: 2D LiDAR sensors, 3D LiDAR sensors • Range of services: Inspection, analysis and restoring of defined functions, Inspection and adaptation of basic settings, parameters of field application, filters for raw data output, and product-specific configuration • Duration: Additional work will be invoiced separately 	Maintenance of LiDAR sensors	1682593

SICK AT A GLANCE

SICK is one of the leading manufacturers of intelligent sensors and sensor solutions for industrial applications. A unique range of products and services creates the perfect basis for controlling processes securely and efficiently, protecting individuals from accidents and preventing damage to the environment.

We have extensive experience in a wide range of industries and understand their processes and requirements. With intelligent sensors, we can deliver exactly what our customers need. In application centers in Europe, Asia and North America, system solutions are tested and optimized in accordance with customer specifications. All this makes us a reliable supplier and development partner.

Comprehensive services complete our offering: SICK LifeTime Services provide support throughout the machine life cycle and ensure safety and productivity.

For us, that is “Sensor Intelligence.”

WORLDWIDE PRESENCE:

Contacts and other locations –www.sick.com