



MAX48C-A3PBDPT1130

MAX

MAGNETOSTRICTIVE LINEAR ENCODERS

SICK
Sensor Intelligence.



Illustration may differ

Ordering information

| Type | Part no. |
|--------------------|----------|
| MAX48C-A3PBDPT1130 | 1119696 |

Accessories not included with delivery, please order separately.

Other models and accessories → www.sick.com/MAX

Detailed technical data

Features

| | |
|-------------------------------|-------------------------|
| Additional information | CAT® Part no.: 612-4823 |
|-------------------------------|-------------------------|

Safety-related parameters

| | |
|--|--|
| MTTF_D (mean time to dangerous failure) | 69 years (EN ISO 13849-1) ^{1) 2)} |
|--|--|

¹⁾ This product is a standard product and does not constitute a safety component as defined in the Machinery Directive. Calculation based on nominal load of components, average ambient temperature of electronic 60 °C, frequency of use 8760 h/a.

²⁾ Every 2nd failure of an electronic component is considered hazardous.

Performance

| | |
|-----------------------------------|--|
| Pressure pipe/End cap | 10 mm |
| Connection type | Male connector, M12, 4-pin |
| Direction of connection | Axial |
| Measuring range | |
| Measured values | Positioning |
| Position (F.S.) | 0 mm ... 1,130 mm ¹⁾ |
| Null zone | 30 mm |
| Damping zone | 70.5 mm |
| Operating conditions | |
| Air humidity | 90 % (Condensation not permitted) |
| Operating pressure P _N | 35 MPa |
| Supply voltage | 9 V DC (7 ... 11 V DC) |
| Switch-on time | < 150 ms |
| Switch-on current | Typ. ≤ 140 mA |
| Measuring frequency (internal) | 2 ms |
| Transmission rate (cycle time) | Type-dependent, according to PWM frequency |
| Accuracy | |
| Setpoint tolerance | Typ. ± 0.5 mm |
| Resolution | Typ. 0.1 mm (noise-free) |
| Hysteresis | ± 0,1 mm |
| Repeatability | Typ. ± 0.2 mm |

¹⁾ F.S. = Full Scale (Measuring range).

²⁾ This product is a standard product and does not constitute a safety component as defined in the Machinery Directive. Calculation based on nominal load of components, average ambient temperature of electronic 60 °C, frequency of use 8760 h/a.

³⁾ Every 2nd failure of an electronic component is considered hazardous.

| | | |
|--------------------------|---------------------------|--|
| | Linearity | $\leq \pm 0.04\%$ F.S. (min. $\leq \pm 0.25$ mm) |
| Temperature drift | | |
| | In the operational status | $\leq \pm 0.04\%$ F.S. (min. $\leq \pm 0.25$ mm) |
| MTTFd | | 69 years (EN ISO 13849-1) ^{2) 3)} |

¹⁾ F.S. = Full Scale (Measuring range).

²⁾ This product is a standard product and does not constitute a safety component as defined in the Machinery Directive. Calculation based on nominal load of components, average ambient temperature of electronic 60°C, frequency of use 8760 h/a.

³⁾ Every 2nd failure of an electronic component is considered hazardous.

Interfaces

| | |
|--------------------------------|-------------|
| Communication interface | PWM |
| Puls width | 10% ... 90% |
| Frequency | 250 Hz |

Electrical data

| | | |
|--|--|------------------------|
| Connection type | Male connector, M12, 4-pin | |
| PIN assignment | 1=n.c.; 2=V DC; 3=GND; 4=SIG | |
| Electrical operation | Supply voltage | 9 V DC (7 ... 11 V DC) |
| | Residual ripple | $\leq \pm 5\%$ S-S |
| | Current consumption | ≤ 50 mA |
| Overtoltage protection during power-up (60 s) | ≤ 36 V at all poles during power-up (60 s) | |
| Reverse polarity protection | ≤ 16 (V DC - GND) | |
| Insulation resistance | 24 V DC (housing) $R_{ISO} \geq 10$ M Ω , 60 s | |
| Dielectric strength | 0 V DC (60 s) to housing ($R_{ISO} \geq 1$ M Ω) | |
| Short-circuit protection | V_S - GND on housing | |

Mechanical data

| | | |
|--------------------|-----------------------------|--|
| Dimensions | Housing | 48 mm, 48f7 for IN cylinder mounting - cylinder bore hole 48H8 |
| | \varnothing pressure pipe | 10 mm |
| | \varnothing O-ring | 40.87 mm x 3.53 mm ¹⁾ |
| | \varnothing support ring | 42.6 mm x 48 mm x 1.4 mm ²⁾ |
| | M12 flange | M12 flange type L: DM 24x24 mm - hole pattern 17 mm (EN 61076-2-101) ³⁾ |
| | Wire length | 130 mm |
| | Material | Housing |
| Pressure pipe | | Stainless steel 1.4306, AISI 304L |
| O-ring | | NBR 75 ¹⁾ |
| Support ring | | PTFE |
| M12 male connector | | Glass fiber reinforced polyamide, nickel-/gold-plated brass contacts |

¹⁾ Acc. to CAT[®] part number 118-8586.

²⁾ Acc. to CAT[®] part number 420-5767.

³⁾ Acc. to CAT[®] part number 435-3388.

| | |
|------------|---|
| M12 flange | Nickel-plated brass with O-ring (NBR) ³⁾ |
| Strands | TPE |

¹⁾ Acc. to CAT[®] part number 118-8586.

²⁾ Acc. to CAT[®] part number 420-5767.

³⁾ Acc. to CAT[®] part number 435-3388 .

Ambient data

| | |
|--|---|
| EMC | |
| Agricultural and forestry machinery | EN ISO 14982 |
| Transient pulses | ISO 7637-1/ISO 7637-2 |
| ESD (air and contact discharge) | ISO 61000-4-2 / ISO 10605 |
| Vibration | |
| Broadband noise (resonance peaks removed) | 20.4 g (r.m.s.), 6 h / spatial axis, 20 ... 2,000 Hz (acc. to CAT [®] EC1 V9.0 Profile 10) |
| Pressure load | |
| Operating pressure P_N | 35 MPa |
| Overload pressure $P_{max} = P_N \times 1.2$ | 42 MPa |
| Test pressure $P_{stat} = P_N \times 1.5$ | 53 MPa |
| Temperature and air humidity | |
| Storage | -20 °C ... +65 °C ¹⁾ |
| Operation (electronics) | -40 °C ... +120 °C |
| Maximum air humidity | 90 % (Condensation not permitted) |
| Enclosure rating | |
| Housing | According to CAT [®] "HOT DUNK TEST" |
| M12 male connector | IP69K (ISO 20653) ²⁾ |

¹⁾ R. H. 55%.

²⁾ With suitable coupling (sealing through O-ring in M12 coupling nut).

Classifications

| | |
|---------------------|----------|
| ECLASS 5.0 | 27270705 |
| ECLASS 5.1.4 | 27270705 |
| ECLASS 6.0 | 27270705 |
| ECLASS 6.2 | 27270705 |
| ECLASS 7.0 | 27270705 |
| ECLASS 8.0 | 27270705 |
| ECLASS 8.1 | 27270705 |
| ECLASS 9.0 | 27270705 |
| ECLASS 10.0 | 27270705 |
| ECLASS 11.0 | 27270705 |
| ECLASS 12.0 | 27274304 |
| ETIM 5.0 | EC002544 |
| ETIM 6.0 | EC002544 |
| ETIM 7.0 | EC002544 |
| ETIM 8.0 | EC002544 |

UNSPSC 16.0901

41111613

Dimensional drawing (Dimensions in mm (inch))

MAX48C

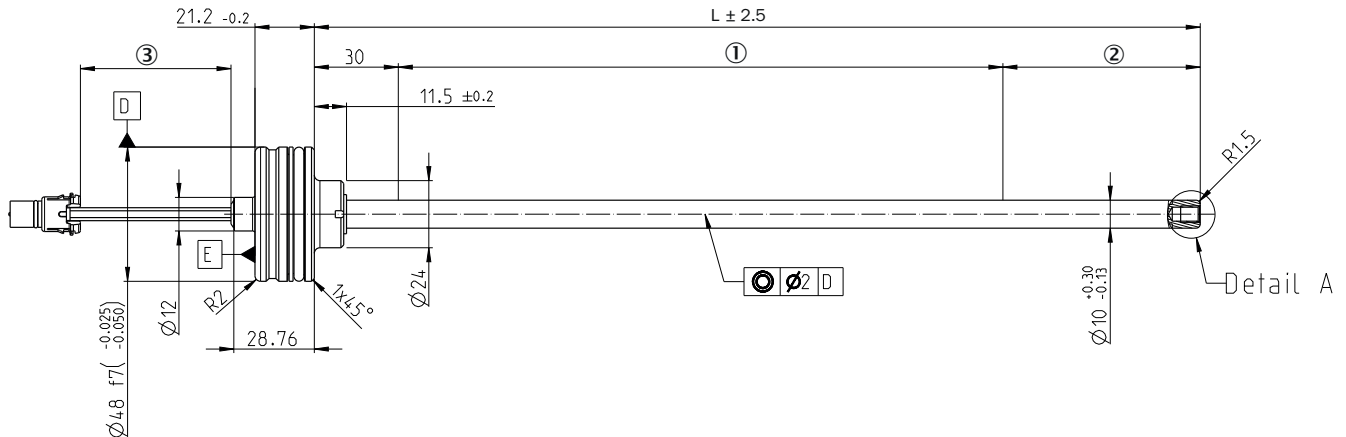

- ① Measuring range
- ② Damping zone
- ③ Wire length

M12 connector type L/ flange - radial seal

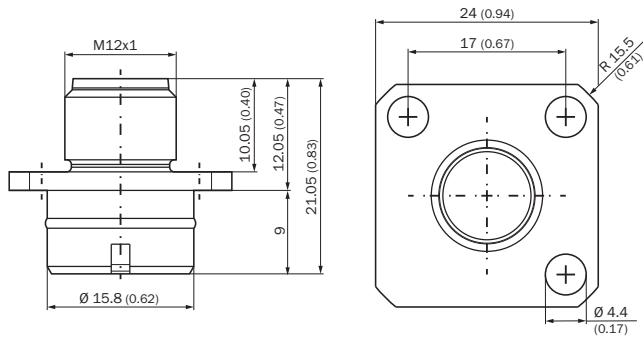

M12 flange type L installation situation

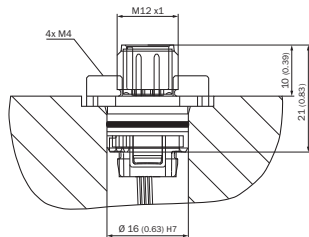

Attachment specifications

Installation space for cylinders

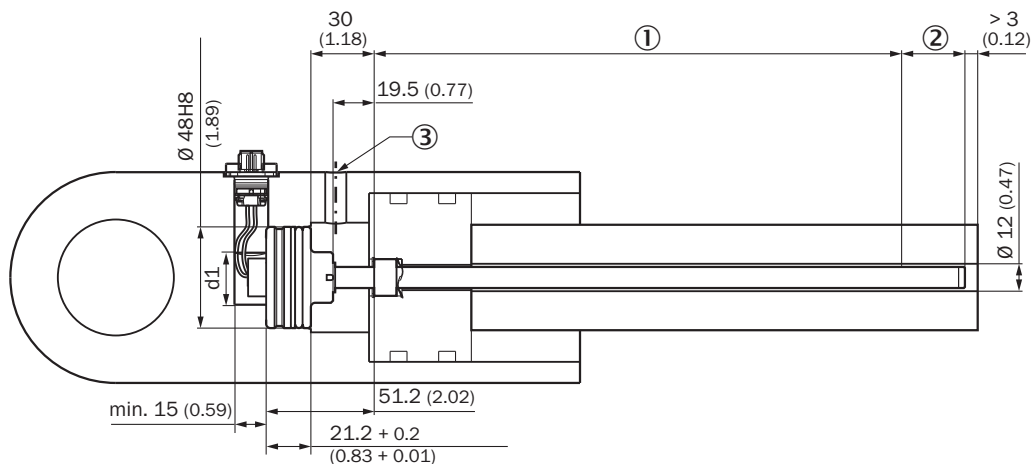

Please note the information in the operating instructions ($d: 32 \leq d1 \leq 40$).

- ① Measuring range
- ② Damping zone
- ③ Hydraulic port

PIN assignment

Pin assignment P (type L)

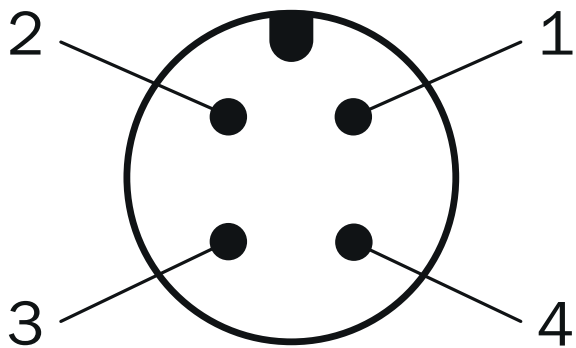

- ① N.C.
- ② V DC
- ③ GND
- ④ Signal

Connection diagram

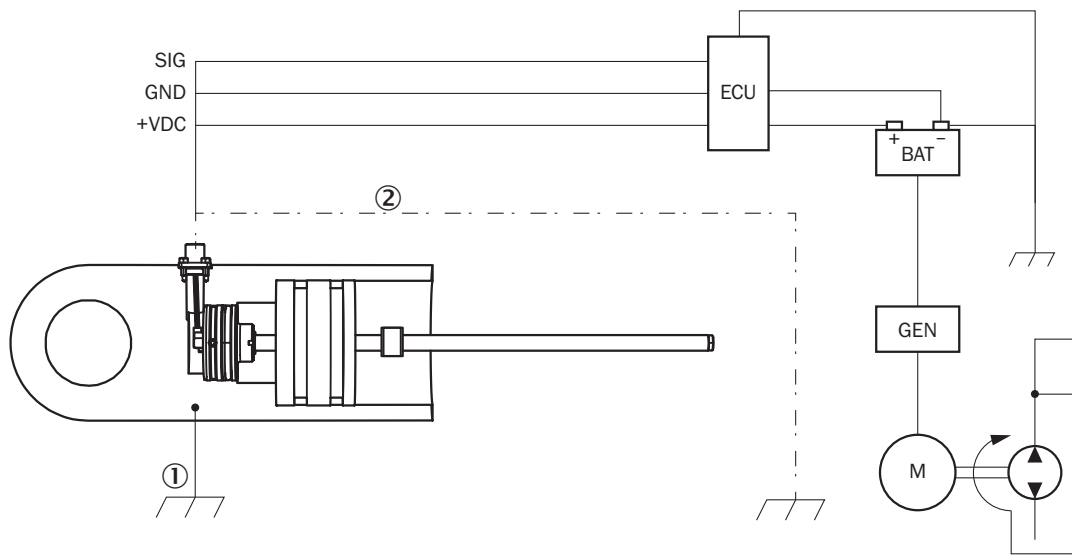

Connection diagram

- ① Chassis GND
- ② Cable shielding (optional)

SICK AT A GLANCE

SICK is one of the leading manufacturers of intelligent sensors and sensor solutions for industrial applications. A unique range of products and services creates the perfect basis for controlling processes securely and efficiently, protecting individuals from accidents and preventing damage to the environment.

We have extensive experience in a wide range of industries and understand their processes and requirements. With intelligent sensors, we can deliver exactly what our customers need. In application centers in Europe, Asia and North America, system solutions are tested and optimized in accordance with customer specifications. All this makes us a reliable supplier and development partner.

Comprehensive services complete our offering: SICK LifeTime Services provide support throughout the machine life cycle and ensure safety and productivity.

For us, that is “Sensor Intelligence.”

WORLDWIDE PRESENCE:

Contacts and other locations –www.sick.com