



MLP1-XXT

Other connectors and cables

SICK
Sensor Intelligence.



Ordering information

Type	Part no.
MLP1-XXT	1078201

Other models and accessories → www.sick.com/Other_connectors_and_cables

Detailed technical data

Technical specifications

Accessory family	Other adapters
Connection type head A	Male connector, M12, 5-pin, A-coded
Connector material	PC
Connector color	Yellow
Reference voltage	≤ 30 V DC
Current loading	3 A
Enclosure rating	IP65 IP67
Description	End connector for serial connection in combination with STR1-XXA
Operating temperature	-25 °C ... +55 °C

Classifications

ECLASS 5.0	27279201
ECLASS 5.1.4	27279201
ECLASS 6.0	27279201
ECLASS 6.2	27279201
ECLASS 7.0	27279201
ECLASS 8.0	27279201
ECLASS 8.1	27279201
ECLASS 9.0	27440106
ECLASS 10.0	27440106
ECLASS 11.0	27440106
ECLASS 12.0	27440106
ETIM 5.0	EC000313
ETIM 6.0	EC000313
ETIM 7.0	EC000313
ETIM 8.0	EC000313
UNSPSC 16.0901	31163032

Dimensional drawing (Dimensions in mm (inch))

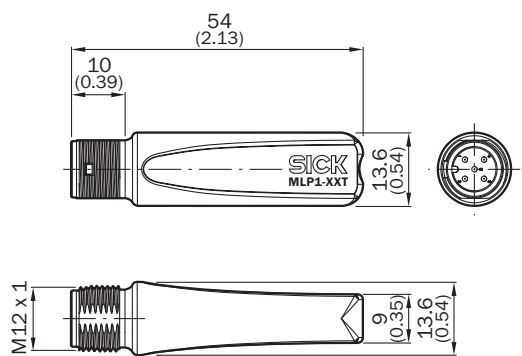

Connection diagram

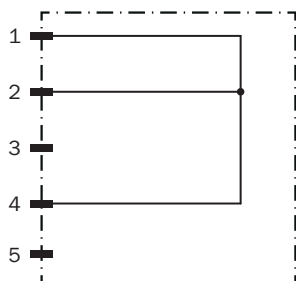

SICK AT A GLANCE

SICK is one of the leading manufacturers of intelligent sensors and sensor solutions for industrial applications. A unique range of products and services creates the perfect basis for controlling processes securely and efficiently, protecting individuals from accidents and preventing damage to the environment.

We have extensive experience in a wide range of industries and understand their processes and requirements. With intelligent sensors, we can deliver exactly what our customers need. In application centers in Europe, Asia and North America, system solutions are tested and optimized in accordance with customer specifications. All this makes us a reliable supplier and development partner.

Comprehensive services complete our offering: SICK LifeTime Services provide support throughout the machine life cycle and ensure safety and productivity.

For us, that is “Sensor Intelligence.”

WORLDWIDE PRESENCE:

Contacts and other locations –www.sick.com