



MRS6224R-131001

MRS6000

3D LIDAR SENSORS

SICK
Sensor Intelligence.



Ordering information

Type	Part no.
MRS6224R-131001	6081153

Other models and accessories → www.sick.com/MRS6000



Detailed technical data

Features

Application	Outdoor, Indoor
Light source	Infrared light (870 nm)
Laser class	1 (IEC 60825-1:2014)
Aperture angle	Horizontal 120°
	Vertical 15°
Scanning frequency	10 Hz
Angular resolution	Horizontal 0.13°
	Vertical 0.625°
Working range	0.5 m ... 200 m
Scanning range	At 10% remission factor 30 m, x 1.4 (typ.) in mode: Extended measuring range
	At 90% remission factor 75 m, x 1.4 (typ.) in mode: Extended measuring range
Amount of evaluated echoes	4

Mechanics/electronics

Connection type	3 x M12 round connectors (supply voltage, Ethernet, I/O)
Supply voltage	10 V ... 29 V
Power consumption	20 W
Housing material	Aluminum / plastic (PMMA)
Housing color	Gray (RAL 7042)
Enclosure rating	IP65
	IP67
Protection class	III
Weight	2.4 kg
Dimensions (L x W x H)	125.5 mm x 176 mm x 131 mm
MTBF	9.5 years

Safety-related parameters

MTF_D	19 years
------------------------	----------

Performance

Systematic error	± 125 mm ¹⁾
Statistical error	30 mm ¹⁾

¹⁾ Typical value; actual value depends on environmental conditions.

Interfaces

Ethernet	✓, TCP/IP
Function	Raw data interface/parameterization
Data transmission rate	100 Mbit/s ... 1 Gbit/s

Ambient data

Ambient operating temperature	-20 °C ... +60 °C
--------------------------------------	-------------------

General notes

Note on use	The sensor does not constitute a safety component as defined by relevant legislation on machine safety.
--------------------	---

Classifications

ECLASS 5.0	27270990
ECLASS 5.1.4	27270990
ECLASS 6.0	27270913
ECLASS 6.2	27270913
ECLASS 7.0	27270913
ECLASS 8.0	27270913
ECLASS 8.1	27270913
ECLASS 9.0	27270913
ECLASS 10.0	27270913
ECLASS 11.0	27270913
ECLASS 12.0	27270913
ETIM 5.0	EC002550
ETIM 6.0	EC002550
ETIM 7.0	EC002550
ETIM 8.0	EC002550
UNSPSC 16.0901	41111615

Dimensional drawing (Dimensions in mm (inch))

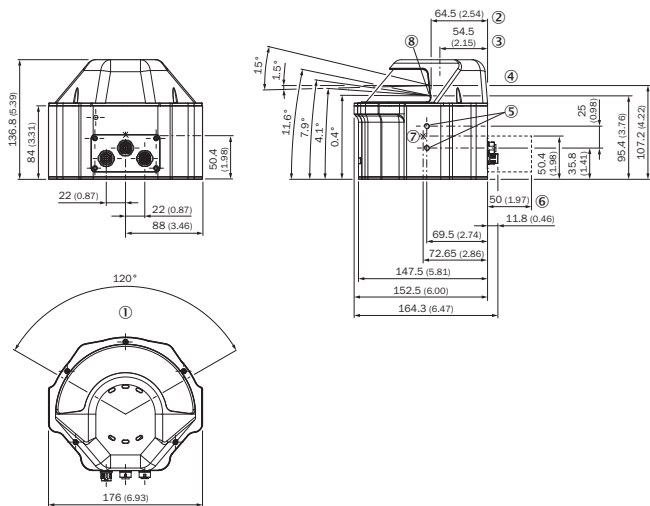

- ① Aperture angle
- ② Zeroset
- ③ Rotation axis
- ④ Horizontal axis
- ⑤ Mounting hole M6 x 10 mm
- ⑥ Area to be kept free for connecting cables
- ⑦ Device center of gravity
- ⑧ Measurement origin

Functional principle

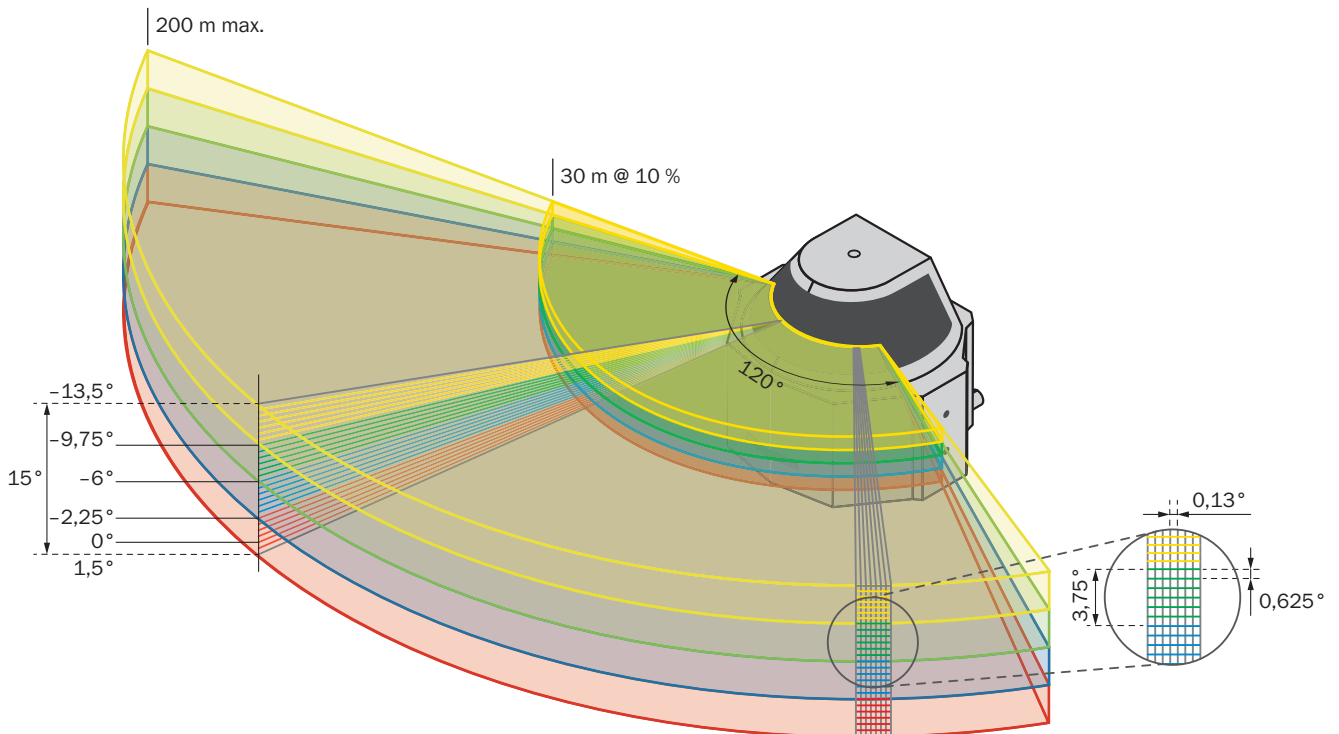

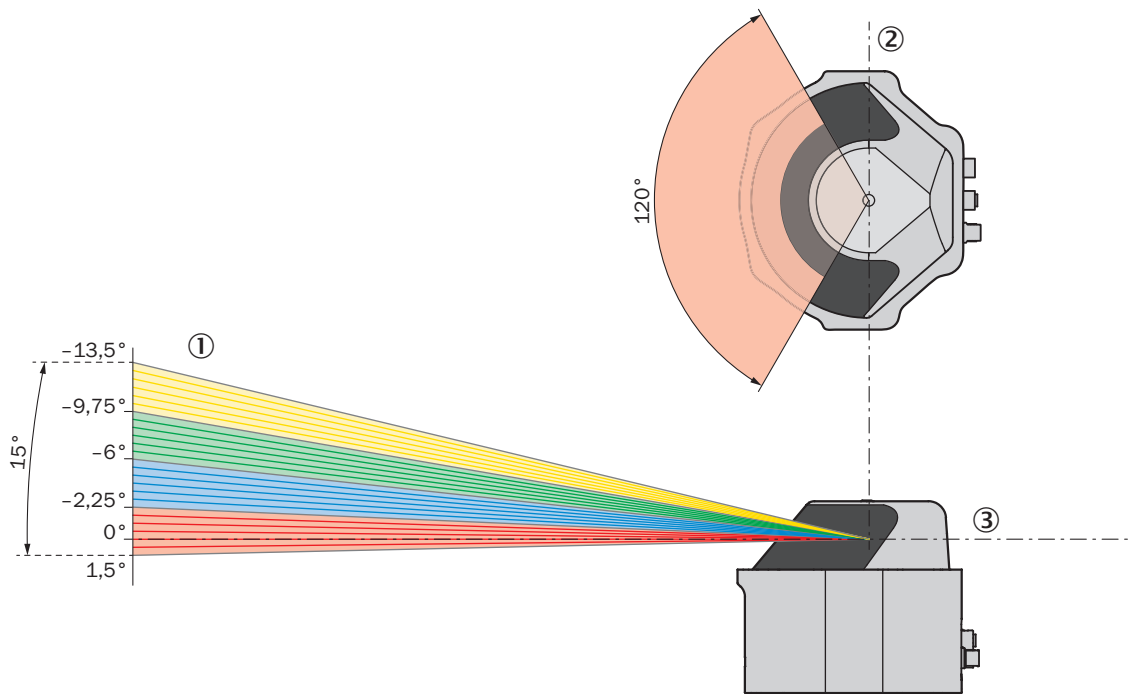

- ① 4 scan planes with 6 layers each
- ② Vertical axis
- ③ Horizontal axis

Recommended accessories

Other models and accessories → www.sick.com/MRS6000

	Brief description	Type	Part no.
Terminal and alignment brackets			
	MRS6000 bracket for mounting from behind, stainless steel, mounting hardware included	Mounting kit	2102120

Recommended services

Additional services → www.sick.com/MRS6000

	Type	Part no.
Commissioning		
<ul style="list-style-type: none"> • Product area: 2D LiDAR sensors, 3D LiDAR sensors • Range of services: Inspection of connection, fine adjustment, configuration of monitored areas, configuration and optimization of parameters as well as tests, Setup of previously defined functions of basic settings, parameters of field application, filters for raw data output and product-specific configuration • Duration: Additional work will be invoiced separately 	Commissioning LiDAR sensors	1680672

	Type	Part no.
Maintenance		
<ul style="list-style-type: none"> • Product area: 2D LiDAR sensors, 3D LiDAR sensors • Range of services: Inspection, analysis and restoring of defined functions, Inspection and adaptation of basic settings, parameters of field application, filters for raw data output, and product-specific configuration • Duration: Additional work will be invoiced separately 	Maintenance of LiDAR sensors	1682593
Extended warranty		
<ul style="list-style-type: none"> • Product area: Machine vision, LiDAR sensors, safety camera sensors, Safety laser scanners, Safety radar sensors, Radar sensors, Fixed mount barcode scanners, Image-based code readers, RFID, Mobile handheld scanners • Range of services: The services correspond to the scope of the statutory manufacturer warranty (SICK general terms of delivery). • Duration: Five-year warranty from delivery date. 	Extended warranty for a total of five years from delivery date	1680671

SICK AT A GLANCE

SICK is one of the leading manufacturers of intelligent sensors and sensor solutions for industrial applications. A unique range of products and services creates the perfect basis for controlling processes securely and efficiently, protecting individuals from accidents and preventing damage to the environment.

We have extensive experience in a wide range of industries and understand their processes and requirements. With intelligent sensors, we can deliver exactly what our customers need. In application centers in Europe, Asia and North America, system solutions are tested and optimized in accordance with customer specifications. All this makes us a reliable supplier and development partner.

Comprehensive services complete our offering: SICK LifeTime Services provide support throughout the machine life cycle and ensure safety and productivity.

For us, that is “Sensor Intelligence.”

WORLDWIDE PRESENCE:

Contacts and other locations –www.sick.com