



# NCV50B-11CCP100100

SPEETEC 1D

NON-CONTACT MOTION SENSORS

**SICK**  
Sensor Intelligence.

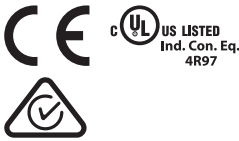

Illustration may differ

### Ordering information

Type	Part no.
NCV50B-11CCP100100	1121431

Other models and accessories → [www.sick.com/SPEETEC\\_1D](http://www.sick.com/SPEETEC_1D)



### Detailed technical data

#### Features

<b>Specialty</b>	<p>SPEETEC closes the gap between tactile measuring wheel systems and complex laser Doppler sensors – and is suitable for almost all surfaces and objects thanks to the non-contact measurement that uses no measuring elements. This opens up new fields of application in motion monitoring.</p> <p>NCV50B is the preferred choice for retrofitting and use in end-customer applications where easy mounting is important. The NCV50B achieves a very high measurement accuracy with large mounting tolerances, which allows quick and easy mounting without a reference measurement or calibration.</p> <p>Non-contact measurement on moving objects without measuring elements.</p> <p>Class 1 laser</p>
------------------	--

#### Safety-related parameters

<b>MTTFd: mean time to dangerous failure</b>	33 years <sup>1)</sup>
--	------------------------

<sup>1)</sup> This product is a standard product and does not constitute a safety component as defined in the Machinery Directive. Calculation based on nominal load of components, average ambient temperature 40 °C, frequency of use 8760 h/a. All electronic failures are considered hazardous. For more information, see document no. 8015532.

#### System

<b>Light source</b>	2 continuous beam lasers <sup>1)</sup>
<b>Wave length</b>	850 nm
<b>Laser class</b>	1 (IEC 60825-1:2014)
<b>Type of light</b>	Invisible infrared light
<b>Typ. measurement field size (distance)</b>	2 mm x 3 mm (at 50 mm) 8 mm x 3 mm (at 45 mm) 8 mm x 3 mm (at 55 mm)
<b>Laser power (per laser)</b>	0.78 mW <sup>2)</sup>

<sup>1)</sup> L10 ≥ 32,500 h (not temperature-dependent). The lasers are always on when the sensor is supplied with voltage. To increase the service life of the sensor, we recommend completely disconnecting the sensor from the voltage supply when it is not needed. No warranty claims relating to the reaching of the service life of the laser will be accepted.

<sup>2)</sup> The device must not be operated if the screen is damaged or missing.

Performance

<b>Nominal measuring distance</b>	50 mm
<b>Static mounting tolerance</b>	Ca. ± 5 mm <sup>1)</sup>
<b>Possible static measuring distance</b>	30 ... 100 mm <sup>2)</sup>
<b>Direction of movement</b>	1D, x-direction
<b>Start/stop</b>	Possible
<b>Movement detection</b>	Bidirectional
<b>Measuring increment (µm/pulse)</b>	100
<b>Speed measuring range</b>	> 0 m/s ... 10 m/s <sup>3)</sup>
<b>Permissible acceleration</b>	≤ 30 m/s <sup>2</sup>
<b>Accuracy</b>	
Measurement accuracy	0.1 % <sup>4)</sup>
Repeatability	0.05 % <sup>5)</sup>
<b>Internal sampling rate</b>	330 µs
<b>Latency</b>	2.9 ms

<sup>1)</sup> Mounting the device closer than the specified measuring distance will not affect the accuracy of the measurement for suitable materials. Operation outside of the tolerance is possible with restrictions.

<sup>2)</sup> The possible measuring distance depends on the material and must be identified in each case for the material used in the application, see the “Permissible measuring distance” table. The static mounting tolerance is included in the range mentioned above and is not additionally available.

<sup>3)</sup> No continuous operation < 0.05 m/s recommended.

<sup>4)</sup> Error limit for systematic measurement deviation in accordance with DIN 1319-1:1995. Valid between 0.2 m/s ... 10 m/s. The achievable measurement accuracy depends on the accuracy of installation. See “Permissible deviations from nominal alignment”.

<sup>5)</sup> Maximum permissible measurement deviation in accordance with DIN 1319-1:1995 under constant conditions. Valid between 0.2 m/s ... 10 m/s, averaged over 0.25 m measuring length.

Electrical data

<b>Supply voltage</b>	12 V ... 30 V
<b>Communication interface</b>	TTL / HTL
<b>Output frequency</b>	≤ 625 kHz
<b>Connection type</b>	Male connector, M12, 8-pin, A-coded <sup>1)</sup>
<b>Parameterization and diagnostic interface with digital input and output</b>	Yes
<b>Parameterising data</b>	TTL or HTL electrical interface Length of the measuring step Direction of movement forward or backward Functionality of the digital inputs and outputs Logic function “Deactivate incremental signal” Logic function “Digital trigger output active after defined length” Customer correction factor to compensate for assembly tolerances
<b>Available diagnostics data</b>	Operating hour counter Sensor temperature Current speed value Current signal-to-noise ratios Indicators for measurement errors due to reflections State of the digital inputs and outputs
<b>Power consumption</b>	< 8 W

<sup>1)</sup> Observe the maximum length of cable: e.g. 20 m at a resolution of 4µm and 1 m/s or 2 m at a resolution of 4µm and 5 m/s: The frequency is calculated differentially with 4-fold evaluation as follows: Frequency = (speed/resolution) / 4; Example: (5.0 m/s / 4µm) / 4 = 312.5 kHz; maximum frequency 625 hKz.

<sup>2)</sup> Short-circuit to another channel or GND permissible for a maximum of 30 s. No protection in the case of a short-circuit channel of U<sub>S</sub>.

<sup>3)</sup> Digital output DO can have an undefined state during this time.

<b>Load current</b>	≤ 30 mA, per channel
<b>Reverse polarity protection</b>	✓
<b>Protection class</b>	III according to DIN EN 61140
<b>Short-circuit resistant outputs</b>	✓ <sup>2)</sup>
<b>Initialization time</b>	Max. 3 s <sup>3)</sup>
<b>Factory setting</b>	Factory setting: output level TTL

<sup>1)</sup> Observe the maximum length of cable: e.g. 20 m at a resolution of 4µm and 1 m/s or 2 m at a resolution of 4µm and 5 m/s: The frequency is calculated differentially with 4-fold evaluation as follows: Frequency = (speed/resolution) / 4; Example: (5.0 m/s / 4µm) / 4 = 312.5 kHz; maximum frequency 625 kHz.

<sup>2)</sup> Short-circuit to another channel or GND permissible for a maximum of 30 s. No protection in the case of a short-circuit channel of U<sub>S</sub>.

<sup>3)</sup> Digital output DO can have an undefined state during this time.

### Mechanical data

<b>Dimensions</b>	140 mm x 95 mm x 32.5 mm (without plug)
<b>Weight</b>	400 g
<b>Material</b>	
	Housing Aluminum
	Screen PMMA
	Plug insert PA66, copper-zinc alloy (CuZn)
<b>Permissible angle</b>	
	Permissible pitch angle ≤ ± 1.5° <sup>1)</sup>
	Permissible yaw angle ≤ ± 1.5° <sup>1)</sup>
	Permissible roll angle ≤ ± 10° <sup>1)</sup>

<sup>1)</sup> Exceeding these values will result in a higher systematic measurement error, see "Permissible deviations from nominal alignment".

### Ambient data

<b>EMC</b>	EN 61000-6-2, EN 61000-6-3
<b>Enclosure rating</b>	IP65 (EN 60529) <sup>1)</sup> IP67 (EN 60529) <sup>1)</sup>
<b>Permissible relative humidity</b>	70 % <sup>2)</sup>
<b>Temperature</b>	
	Operating temperature range 0 °C ... +45 °C <sup>3)</sup>
	Storage temperature range -32 °C ... +60 °C, without package
<b>Resistance</b>	
	Resistance to shocks 30 g, 6 ms (EN 60068-2-27)
	Resistance to vibration 20 g, 10 Hz ... 2,000 Hz (EN 60068-2-6)

<sup>1)</sup> For suitable mating connector and correct mounting of the mating connector.

<sup>2)</sup> Condensation on laser modules and screen not permitted.

<sup>3)</sup> If the permissible temperature range is exceeded, the sensor switches off the laser to protect it against damage. No signal is outputted in this case. The variant with parameterization and diagnostic functions offers the option of monitoring the internal temperature and therefore the reserves up until the point of switching off.

### Classifications

<b>ECLASS 5.0</b>	27270790
<b>ECLASS 5.1.4</b>	27270790
<b>ECLASS 6.0</b>	27270790
<b>ECLASS 6.2</b>	27270790

<b>ECLASS 7.0</b>	27270790
<b>ECLASS 8.0</b>	27270790
<b>ECLASS 8.1</b>	27270790
<b>ECLASS 9.0</b>	27270790
<b>ECLASS 10.0</b>	27270790
<b>ECLASS 11.0</b>	27270790
<b>ECLASS 12.0</b>	27275201

Dimensional drawing (Dimensions in mm (inch))

Mounting side

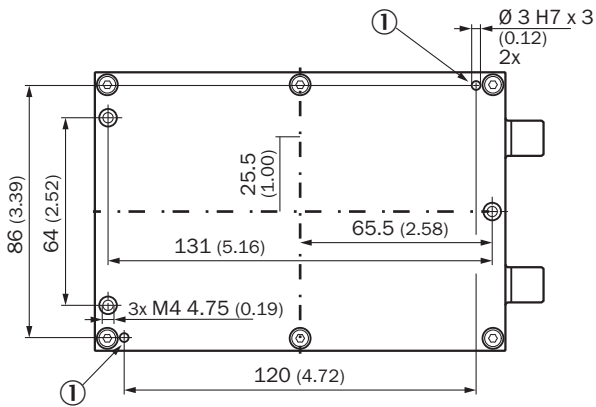

① Ø 3 H7 x 3 holes for accommodating locating pins

Side view with threaded holes for proximity sensors

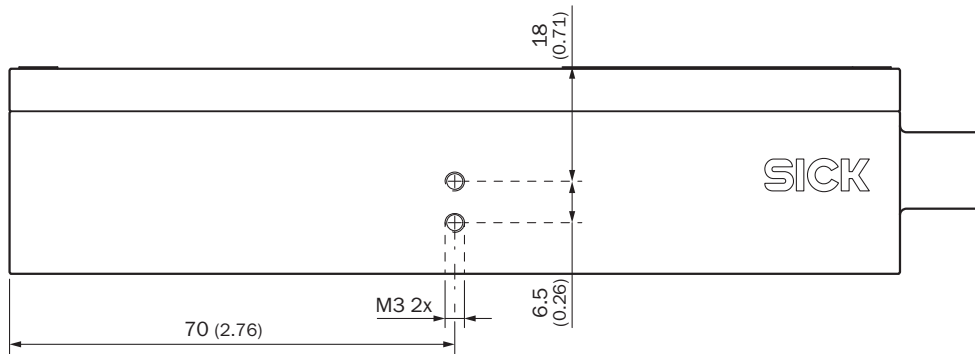

Side view with threaded holes for proximity sensors

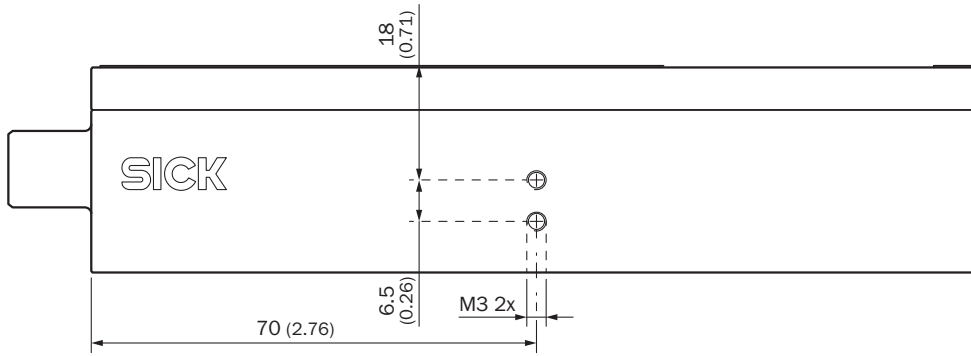

SPEETEC 1D

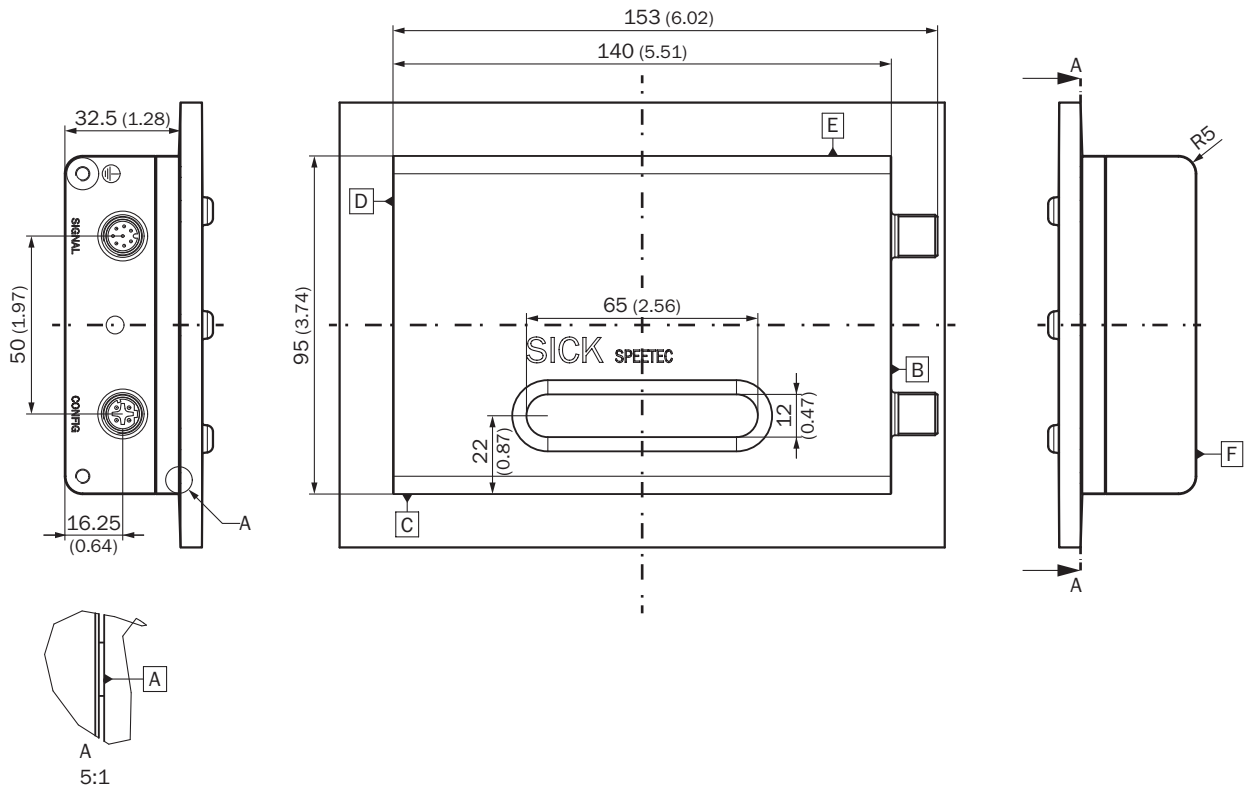

### Attachment specifications

Nominal alignment of the sensor to the surface (z-axis)

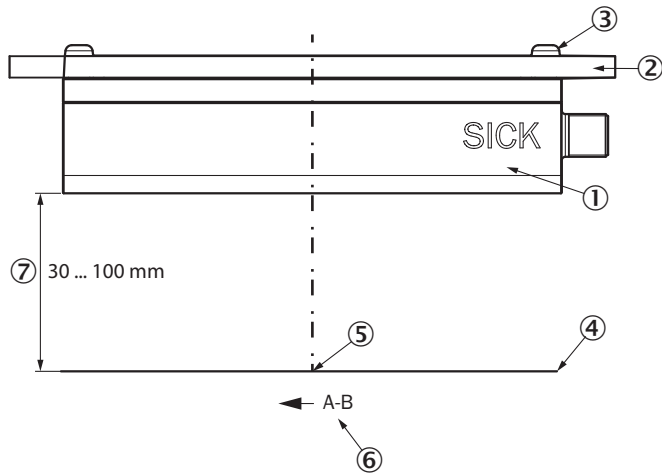

- ① Sensor
- ② Mounting surface
- ③ M4 screws
- ④ Surface to be measured
- ⑤ Measuring point on x-/y-plane, 82.5 mm away from the mounting level
- ⑥ Forward material movement; signal sequence A before B
- ⑦ Measuring distance between sensor and surface, also see “Permissible measuring distance” table

Material	Permissible measuring distance
Wood, sawed	30 ... 100 mm
Paper, white	30 ... 100 mm
Conveyor belt, black	50 ... 80 mm
Textile	40 ... 60 mm

### PIN assignment

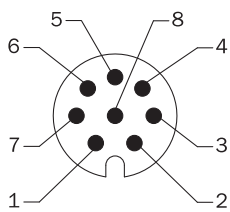

M12 signal male connector, 8-pin and cable, 8-wire

Male connector M12, 8-pin	Wire color	TTL, HTL standard signal	TTL, HTL signal can be programmed	Explanation
1	Brown	A-	A-	Signal cable
2	White	A	A	Signal cable
3	Black	B-	B-	Signal cable
4	Pink	B	B	Signal cable
5	Yellow	Do not wire!	Digital output	Warning: Observe signal variant!
6	Violet	Do not wire!	Digital input	Warning: Observe signal variant!

Male connector M12, 8-pin	Wire color	TTL, HTL standard signal	TTL, HTL signal can be programmed	Explanation
7	Blue	GND	GND	Ground connection of the sensor
8	Red	+U <sub>S</sub>	+U <sub>S</sub>	Supply voltage
Screen	Screen	Screen	Screen	Connect screen to housing on sensor side, connect to earth on the control side
Ground	Earthing point on housing			The sensor must be earthed via the housing at the intended earthing point.
<b>Technical data of digital input</b>				
Type	Current Sink Type 1/3			
Input voltage HIGH	15 V ... 30 V			
Input voltage LOW	-3 V ... 5 V			
Input current HIGH	2 mA ... 2.6 mA			
Input current LOW	0 mA ... 2.6 mA			
<b>Technical data of digital output</b>				
Type	Push-Pull Output			
Output voltage HIGH	(U <sub>S</sub> - 2 V) ... U <sub>S</sub>			
Output voltage LOW	0 V ... 2 V			
Output current HIGH	0.5 mA ... 30 mA			

### Diagrams

Signal outputs for electrical interfaces TTL and HTL with forward material movement (see assembly specifications)

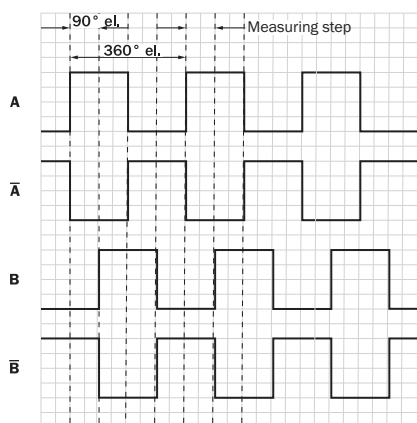

The measuring step corresponds to 90° electrical. The measuring step [µm/pulse] specified under Performance can only be achieved if the output signals of the sensor are evaluated differentially.



Operation note

Permissible deviations from nominal alignment

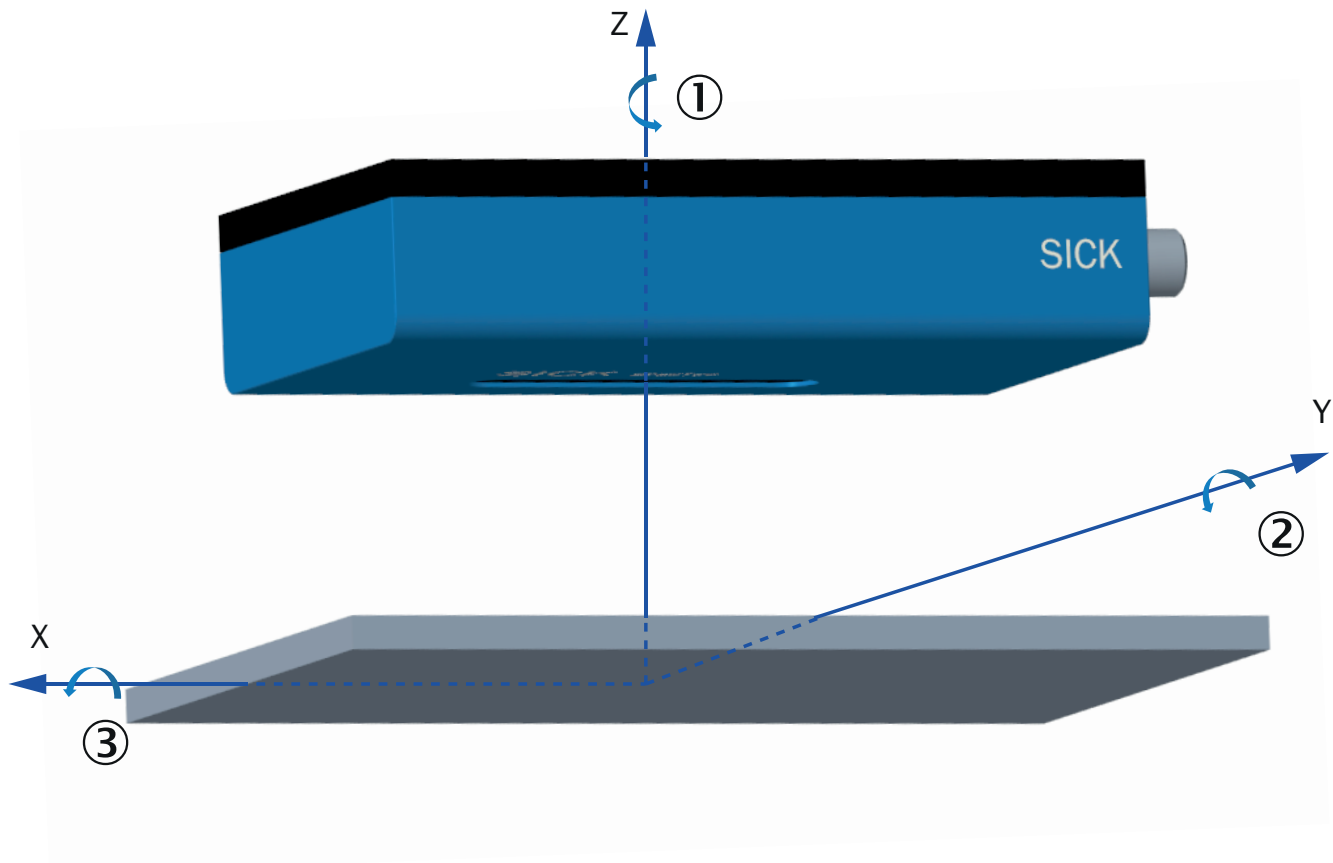







- ① Yaw angle
- ② Pitch angle
- ③ Roll angle

Pitch angle	NCV50B accuracy
0,05°	0,10%
0,10°	0,10%
0,20°	0,10%
0,30°	0,10%
0,50°	0,10%
0,75°	0,10%
1,00°	0,10%
1,50°	0,10%

### Recommended accessories

Other models and accessories → [www.sick.com/SPEETEC\\_1D](http://www.sick.com/SPEETEC_1D)

	Brief description	Type	Part no.
<b>Alignment aids</b>			
	Laser spot detector map to visualize the SPEETEC NCV50 laser spot for the eye and to determine the correct operating point.	BEF-SPEETEC-LSD	2120614
<b>Optics cloths</b>			
	Cloth for cleaning optical surfaces	Lens cloth	4003353
<b>Programming and configuration tools</b>			
	PC programming unit for programmable SPEETEC 1D. Connects the configuration connection of SPEETEC 1D programmable sensors to a PC / laptop, enabling parameterization and diagnostics via SOPAS ET. The interface is not designed as a permanent connection. The cable of the programming device must not be extended.	PGT-14	1121562
<b>Signal and status indicators</b>			
	Digital display with resistive touch screen, for SPEETEC, incremental encoders and measuring wheel encoders. Multi-function device for use as tachometer, speed measuring device, pulse counter, position display, piece counter and total counter. Communication interface: incremental. Communication interface detailed: RS-422, RS485	DIS-IPDTACCR0000	4119630
<b>Device protection (mechanical)</b>			
	Table housing suitable for installation of the DIS-IPDTACCR0000 display unit	DIS-DH30M	7135599
<b>Mounting brackets and plates</b>			
	Mounting bracket for MWS120 measuring wheel system and SPEETEC 1D laser surface motion sensors	BEF-WF-MWS-NCV	2113284
	1 piece, The BEF-WN-NCV50 mounting bracket makes it possible to easily and correctly mount the sensors while complying with the specified tolerances for distance and angle. The BEF-WN-NCV50 mounting bracket can be combined with the BEF-WF-MWS120 mounting bracket. This makes it possible to mount on the machine frame., Mounting bracket, screws for mounting the NCV50	BEF-WN-NCV50 mounting bracket	2117456
<b>Terminal and alignment brackets</b>			
	1 piece, Bracket for mounting SICK photoelectric proximity sensors, W4, W9, G6 to the NCV50. SICK photoelectric proximity sensors from the W4, W9, G6 series can be easily mounted on the NCV50 using the BEF-MK-NCV50-W49G6. This makes it possible to better detect material edges and makes length measurement more exact. The position of the scanning point in the direction of movement is specified by the mounting position, the position in the y-direction can be adjusted using the bracket slots., Adjustment aid, screws for mounting the photoelectric proximity sensor	BEF-MK-NCV50-W49G6	2117457
	Suitable for NCV50 / SPEETEC. Simplifies mounting of the SPEETEC at the right distance and angle to the surface. Packaging unit: 1 unit, Adjustment aid, screws for mounting the NCV50	BEF-WN-NCV50-ADJUST	2117003
<b>Others</b>			
	<ul style="list-style-type: none"> <li>• <b>Connection type head A:</b> Female connector, M12, 8-pin, straight</li> <li>• <b>Connection type head B:</b> Flying leads</li> <li>• <b>Signal type:</b> Incremental, SSI</li> <li>• <b>Cable:</b> 2 m, 8-wire, PUR, halogen-free</li> <li>• <b>Description:</b> Incremental, SSI, shielded, Head A: female connector, M12, 8-pin, straight Head B: cable Cable: suitable for drag chain, PVC, shielded, 4 x 2 x 0.25 mm<sup>2</sup>, Ø 7.0 mm</li> <li>• <b>Connection systems:</b> Flying leads</li> </ul>	DOL-1208-G02MAC1	6032866

	Brief description	Type	Part no.
	<ul style="list-style-type: none"> <li>• <b>Connection type head A:</b> Female connector, M12, 8-pin, straight</li> <li>• <b>Connection type head B:</b> Flying leads</li> <li>• <b>Signal type:</b> Incremental, SSI</li> <li>• <b>Cable:</b> 5 m, 8-wire, PUR, halogen-free</li> <li>• <b>Description:</b> Incremental, SSI, shielded, Head A: female connector, M12, 8-pin, straight Head B: cable Cable: suitable for drag chain, PVC, shielded, 4 x 2 x 0.25 mm<sup>2</sup>, Ø 7.0 mm</li> <li>• <b>Connection systems:</b> Flying leads</li> </ul>	DOL-1208-G05MAC1	6032867
		DOL-1208-G05MAD3	2121359
	<ul style="list-style-type: none"> <li>• <b>Connection type head A:</b> Female connector, M12, 8-pin, straight</li> <li>• <b>Connection type head B:</b> Flying leads</li> <li>• <b>Signal type:</b> Incremental, SSI</li> <li>• <b>Cable:</b> 10 m, 8-wire, PUR, halogen-free</li> <li>• <b>Description:</b> Incremental, SSI, shielded, Head A: female connector, M12, 8-pin, straight Head B: cable Cable: suitable for drag chain, PVC, shielded, 4 x 2 x 0.25 mm<sup>2</sup>, Ø 7.0 mm</li> <li>• <b>Connection systems:</b> Flying leads</li> </ul>	DOL-1208-G10MAC1	6032868
	<ul style="list-style-type: none"> <li>• <b>Connection type head A:</b> Female connector, M12, 8-pin, straight</li> <li>• <b>Connection type head B:</b> Flying leads</li> <li>• <b>Signal type:</b> Incremental, SSI</li> <li>• <b>Cable:</b> 20 m, 8-wire, PUR, halogen-free</li> <li>• <b>Description:</b> Incremental, SSI, shielded, Head A: female connector, M12, 8-pin, straight Head B: cable Cable: suitable for drag chain, PVC, shielded, 4 x 2 x 0.25 mm<sup>2</sup>, Ø 7.0 mm</li> <li>• <b>Connection systems:</b> Flying leads</li> </ul>	DOL-1208-G20MAC1	6032869
	<ul style="list-style-type: none"> <li>• <b>Connection type head A:</b> Female connector, M12, 8-pin, straight</li> <li>• <b>Connection type head B:</b> Male connector, M12, 8-pin, straight</li> <li>• <b>Cable:</b> 5 m, 8-wire, PUR, halogen-free</li> <li>• <b>Description:</b> Shielded, Connection cable, M12, 8-pin, straight male connector / straight female connector, 2 m, PUR halogen-free, shielded</li> </ul>	DSL-1208-G05MAC1	6032913
	<ul style="list-style-type: none"> <li>• <b>Connection type head A:</b> Flying leads</li> <li>• <b>Connection type head B:</b> Flying leads</li> <li>• <b>Signal type:</b> SSI, Incremental</li> <li>• <b>Items supplied:</b> By the meter</li> <li>• <b>Cable:</b> 11-wire, PUR</li> <li>• <b>Description:</b> SSI, Incremental, shielded</li> </ul>	LTG-2411-MW	6027530
	<ul style="list-style-type: none"> <li>• <b>Connection type head A:</b> Flying leads</li> <li>• <b>Connection type head B:</b> Flying leads</li> <li>• <b>Signal type:</b> SSI, Incremental</li> <li>• <b>Items supplied:</b> By the meter</li> <li>• <b>Cable:</b> 12-wire, PUR, halogen-free</li> <li>• <b>Description:</b> SSI, Incremental, shielded</li> </ul>	LTG-2512-MW	6027531
	<ul style="list-style-type: none"> <li>• <b>Connection type head A:</b> Flying leads</li> <li>• <b>Connection type head B:</b> Flying leads</li> <li>• <b>Signal type:</b> SSI, TTL, HTL, Incremental</li> <li>• <b>Items supplied:</b> By the meter</li> <li>• <b>Cable:</b> 12-wire, UV and saltwater-resistant, PUR, halogen-free</li> <li>• <b>Description:</b> SSI, TTL, HTL, Incremental, shielded, Head A: cable Head B: cable Cable: suitable for drag chain, PUR, halogen-free, shielded, UV and saltwater resistant, 4 x 2 x 0.25 mm<sup>2</sup> + 2 x 0.5 mm<sup>2</sup> + 2 x 0.14 mm<sup>2</sup>, Ø 7.8 mm</li> </ul>	LTG-2612-MW	6028516
	<ul style="list-style-type: none"> <li>• <b>Connection type head A:</b> Female connector, M12, 8-pin, straight, A-coded</li> <li>• <b>Description:</b> Shielded</li> <li>• <b>Connection systems:</b> Screw-type terminals</li> <li>• <b>Permitted cross-section:</b> 0.25 mm<sup>2</sup> ... 0.5 mm<sup>2</sup></li> </ul>	DOS-1208-GA	6028369
	<ul style="list-style-type: none"> <li>• <b>Connection type head A:</b> Male connector, M12, 8-pin, straight, A-coded</li> <li>• <b>Description:</b> Shielded</li> <li>• <b>Connection systems:</b> Screw-type terminals</li> <li>• <b>Permitted cross-section:</b> ≤ 0.5 mm<sup>2</sup></li> </ul>	STE-1208-GA	6028370

	Brief description	Type	Part no.
	<ul style="list-style-type: none"> <li>• <b>Connection type head A:</b> Female connector, M12, 8-pin, angled</li> <li>• <b>Connection type head B:</b> Flying leads</li> <li>• <b>Signal type:</b> HIPERFACE<sup>®</sup>, Incremental</li> <li>• <b>Cable:</b> 20 m, 8-wire, PUR</li> <li>• <b>Description:</b> HIPERFACE<sup>®</sup>, Incremental, shielded</li> </ul>	DOL-1208-W20MAC1	6037727
	<ul style="list-style-type: none"> <li>• <b>Connection type head A:</b> Female connector, M12, 8-pin, angled</li> <li>• <b>Connection type head B:</b> Flying leads</li> <li>• <b>Signal type:</b> HIPERFACE<sup>®</sup>, Incremental</li> <li>• <b>Cable:</b> 2 m, 8-wire, PUR, halogen-free</li> <li>• <b>Description:</b> HIPERFACE<sup>®</sup>, Incremental, shielded</li> </ul>	DOL-1208-W02MAC1	6037724
	<ul style="list-style-type: none"> <li>• <b>Connection type head A:</b> Female connector, M12, 8-pin, angled</li> <li>• <b>Connection type head B:</b> Flying leads</li> <li>• <b>Signal type:</b> HIPERFACE<sup>®</sup>, Incremental</li> <li>• <b>Cable:</b> 5 m, 8-wire, PUR, halogen-free</li> <li>• <b>Description:</b> HIPERFACE<sup>®</sup>, Incremental, shielded</li> </ul>	DOL-1208-W05MAC1	6037725
	<ul style="list-style-type: none"> <li>• <b>Connection type head A:</b> Female connector, M12, 8-pin, angled</li> <li>• <b>Connection type head B:</b> Flying leads</li> <li>• <b>Signal type:</b> HIPERFACE<sup>®</sup>, Incremental</li> <li>• <b>Cable:</b> 10 m, 8-wire, PUR, halogen-free</li> <li>• <b>Description:</b> HIPERFACE<sup>®</sup>, Incremental, shielded</li> </ul>	DOL-1208-W10MAC1	6037726
	<ul style="list-style-type: none"> <li>• <b>Connection type head A:</b> Female connector, M12, 8-pin, angled, A-coded</li> <li>• <b>Signal type:</b> Ethernet</li> <li>• <b>Cable:</b> CAT5, CAT5e</li> <li>• <b>Description:</b> Ethernet, shielded, M12 female connector, A-coded</li> <li>• <b>Connection systems:</b> QUICKON connection</li> <li>• <b>Permitted cross-section:</b> 0.14 mm<sup>2</sup> ... 0.34 mm<sup>2</sup></li> </ul>	DOS-1208-WA	6043358
	<ul style="list-style-type: none"> <li>• <b>Connection type head A:</b> Female connector, M12, 8-pin, straight, A-coded</li> <li>• <b>Connection type head B:</b> Male connector, M12, 8-pin, straight, A-coded</li> <li>• <b>Connection type head C:</b> Female connector, M8, 4-pin, A-coded</li> <li>• <b>Signal type:</b> Sensor/actuator cable</li> <li>• <b>Items supplied:</b> Cable A: YM2A28-C20UA6F2A28 (6079346), cable B: YM2A18-C20UA3F8U14 (6079404), Y-distributor: YM2A28-000000FY2A8 (2123351)</li> <li>• <b>Cable:</b> 0.2 m</li> <li>• <b>Description:</b> Sensor/actuator cable, Y-distribution, 1 x female connector M12, 8-pin, straight, 1 x male connector M12, 8-pin, straight, 1 x female connector M8, 4-pin, straight, 0.2 m PUR cable for providing trigger signal for NCV50</li> </ul>	YM2A28-C20S01MYAAX	2124388
Photoelectric sensors			
	<ul style="list-style-type: none"> <li>• <b>Sensing range max.:</b> 5 mm ... 250 mm</li> <li>• <b>Functional principle:</b> Photoelectric proximity sensor</li> <li>• <b>Connection type:</b> Cable with connector M8, 3-pin</li> <li>• <b>Type of light:</b> Visible red light</li> <li>• <b>Adjustment:</b> Potentiometer</li> <li>• <b>Housing:</b> Rectangular</li> </ul>	GTB6-P5211	1059333
	<ul style="list-style-type: none"> <li>• <b>Sensing range max.:</b> 5 mm ... 250 mm</li> <li>• <b>Functional principle:</b> Photoelectric proximity sensor</li> <li>• <b>Connection type:</b> Cable with M8 male connector, 4-pin</li> <li>• <b>Type of light:</b> Visible red light</li> <li>• <b>Adjustment:</b> Potentiometer</li> <li>• <b>Housing:</b> Rectangular</li> </ul>	GTB6-P6211	1059320
	<ul style="list-style-type: none"> <li>• <b>Sensing range max.:</b> 25 mm ... 300 mm</li> <li>• <b>Functional principle:</b> Photoelectric proximity sensor</li> <li>• <b>Connection type:</b> Cable with M8 male connector, 4-pin</li> <li>• <b>Type of light:</b> Visible red light</li> <li>• <b>Adjustment:</b> Potentiometer</li> <li>• <b>Housing:</b> Rectangular</li> </ul>	WTB4SL-3P3261	1058238

	Brief description	Type	Part no.
	<ul style="list-style-type: none"> <li>• <b>Sensing range max.:</b> 20 mm ... 350 mm</li> <li>• <b>Functional principle:</b> Photoelectric proximity sensor</li> <li>• <b>Functional principle detail:</b> Background suppression</li> <li>• <b>Switching output:</b> PNP</li> <li>• <b>Switching mode:</b> Light/dark switching</li> <li>• <b>Connection type:</b> Cable with M8 male connector, 4-pin, 120 mm</li> <li>• <b>Light source:</b> PinPoint LED</li> <li>• <b>Adjustment:</b> Potentiometer</li> </ul>	WTB9-3P3261	1054306
	<ul style="list-style-type: none"> <li>• <b>Sensing range max.:</b> 25 mm ... 300 mm</li> <li>• <b>Functional principle:</b> Photoelectric proximity sensor</li> <li>• <b>Functional principle detail:</b> Background suppression</li> <li>• <b>Switching output:</b> PNP</li> <li>• <b>Switching mode:</b> Light/dark switching</li> <li>• <b>Connection type:</b> Cable with M8 male connector, 4-pin, 120 mm</li> <li>• <b>Light source:</b> Laser</li> <li>• <b>Adjustment:</b> Potentiometer</li> </ul>	WTB9L-3P3261S03	1073333

## SICK AT A GLANCE

SICK is one of the leading manufacturers of intelligent sensors and sensor solutions for industrial applications. A unique range of products and services creates the perfect basis for controlling processes securely and efficiently, protecting individuals from accidents and preventing damage to the environment.

We have extensive experience in a wide range of industries and understand their processes and requirements. With intelligent sensors, we can deliver exactly what our customers need. In application centers in Europe, Asia and North America, system solutions are tested and optimized in accordance with customer specifications. All this makes us a reliable supplier and development partner.

Comprehensive services complete our offering: SICK LifeTime Services provide support throughout the machine life cycle and ensure safety and productivity.

For us, that is “Sensor Intelligence.”

## WORLDWIDE PRESENCE:

Contacts and other locations –[www.sick.com](http://www.sick.com)