



# PICS150-01000 Pro-2 6 I/O

picoScan100

2D LIDAR SENSORS

**SICK**  
Sensor Intelligence.



### Ordering information

Type	Part no.
PICS150-01000 Pro-2 6 I/O	1142273

Other models and accessories → [www.sick.com/picoScan100](http://www.sick.com/picoScan100)



### Detailed technical data

#### Features

<b>Application</b>	Indoor, Outdoor
<b>Variant</b>	Standard (not pre-configured)
<b>Measurement principle</b>	HDDM <sup>+</sup>
<b>Light source</b>	Infrared (905 nm)
<b>Laser class</b>	1 (IEC 60825-1:2014, EN 60825-1:2014+A11:2021)
<b>Aperture angle</b>	Horizontal 276°
<b>Scanning frequency</b>	15 Hz 20 Hz 25 Hz 30 Hz 40 Hz 50 Hz Depends on the Dynamic Sensing Profile <sup>1)</sup>
<b>Angular resolution</b>	Horizontal 0.05° 0.1° 0.125° 0.25° 0.33° 0.5° 1° Depends on the Dynamic Sensing Profile <sup>1)</sup>
<b>Scan field flatness</b>	± 1°
<b>Working range</b>	0.05 m ... 120 m <sup>1)</sup>
<b>Blind zone</b>	0 m ... 0.05 m
<b>Scanning range</b>	At 90% remission and 10 klx 75 m

<sup>1)</sup> For details, see the working range diagram in the technical drawings section.

At 10% remission and 10 klx	40 m
<b>Spot size</b>	Divergence, typ.: 4.8 mrad On the optics cover: 8 mm
<b>Amount of evaluated echoes</b>	3 (included)

<sup>1)</sup> For details, see the working range diagram in the technical drawings section.

## Mechanics/electronics

<b>Connection type</b>	2 x M12 round connector
<b>System plug</b>	See system plug 2130754, Assembled to the rear
<b>Supply voltage</b>	9 V DC ... 30 V DC
<b>Power consumption</b>	Typ. 4.5 W, max. 17 W with loaded digital outputs, see system plug 2130754
<b>Output current</b>	≤ 200 mA
<b>Housing material</b>	Aluminum with Suretec650 coating
<b>Housing color</b>	Anthracite gray (RAL 7016)
<b>Optical hood</b>	Polycarbonate, scratch-resistant coating
<b>Enclosure rating</b>	IP65 (IEC 60529:1989+AMD1:1999+AMD2:2013) <sup>1)</sup> IP67 (IEC 60529:1989+AMD1:1999+AMD2:2013) <sup>1)</sup>
<b>Protection class</b>	III (IEC 61140:2016-11)
<b>Electrical safety</b>	IEC 61010-1:2010-06+AMD1:2016
<b>Weight</b>	220 g, without system plug
<b>Dimensions (L x W x H)</b>	60 mm x 60 mm x 82 mm
<b>Ventilation element</b>	Yes
<b>MTBF</b>	> 100 years

<sup>1)</sup> With system plug connected.

## Safety-related parameters

<b>MTTF<sub>D</sub></b>	> 100 years, at 25 °C ambient temperature (EN ISO 13849-1:2015)
-------------------------	---

## Performance

<b>Data output per scan segment</b>	Segment size 30° at ≤ 25 Hz, Segment size 60° at ≥ 30 Hz
<b>Scan/frame rate</b>	12,546 measurement point/s ... 264,963 measurement point/s, Depends on the Dynamic Sensing Profile and number of echoes
<b>Latency of the measurement data output</b>	Segment size 30° at < 25 Hz: ≤ 10 ms (3 σ) Segment size 60° at ≥ 30 Hz: ≤ 15 ms (3 σ), Depends on the Dynamic Sensing Profile and number of echoes
<b>Detectable object shape</b>	Almost any
<b>Systematic error</b>	Typ. ± 20 mm <sup>1)</sup> Max. ± 30 mm
<b>Statistical error</b>	≤ 5 mm (0.05 m ... 5 m) <sup>2)</sup>
<b>Integrated application</b>	Output of measurement data 2D Object Detection 2D Object Detection Advanced
<b>Digital add-ons</b>	Dynamic Sensing Profile package, Data Reduction & Data Preparation package, Reliability package, Multi-echo technology, LMDscandata (data format), Reflector detection, IMU (Inertial Measurement Unit), PTP, Native ROS2

<sup>1)</sup> Typical value; real value depends on ambient conditions and the selected Dynamic Sensing Profile.

<sup>2)</sup> 10 klx and 100 klx.

<b>Number of field sets</b>	48 fields
<b>Simultaneous evaluation cases</b>	> 10 (The number of simultaneous evaluation cases depends on the field geometry)

<sup>1)</sup> Typical value; real value depends on ambient conditions and the selected Dynamic Sensing Profile.

<sup>2)</sup> 10 klx and 100 klx.

### Software functions

<b>Dynamic Sensing Profile package</b>	Included <sup>1)</sup>
<b>Data Reduction &amp; Data Preparation package</b>	Included (Moving average filter, Interval filter, Scan range filter, Rectangular filter, Distance filter)
<b>Reliability package</b>	Included (Fog filter, Particle filter)
<b>Multi-echo technology</b>	Included
<b>LMDscandata (data format)</b>	Included
<b>Reflector detection</b>	Included
<b>IMU (Inertial Measurement Unit)</b>	Included
<b>PTP</b>	Included
<b>Native ROS2</b>	Included

<sup>1)</sup> For details, see the working range diagram in the technical drawings section.

### Interfaces

<b>Ethernet</b>	✓, UDP/IP Singlecast (Compact, MSGPACK), UDP/IP Multicast (Compact, MSGPACK), TCP/IP (LMDscandata), Native ROS2 (Data Distribution Service, DDS)
Function	Measurement data output (distance, RSSI, time stamp, reflector mark), Field status information, DHCP, NTP, PTP
Data transmission rate	10 Mbit/s ... 100 Mbit/s, half/full-duplex
<b>Digital inputs/outputs</b>	6, customizable, see system plug 2130754
<b>Optical indicators</b>	2 LEDs
<b>Configuration software</b>	SOPASair (web browser)SOPAS ET (software)REST API
<b>Driver</b>	ROS1, ROS2, C++, Python

### Ambient data

<b>Object remission</b>	1.8 % ... > 1,000 % (Reflector)
<b>Electromagnetic compatibility (EMC)</b>	
Emitted radiation	Industrial environment (IEC 61000-6-4:2018 / EN IEC 61000-6-4:2019 / IEC 61000-6-4:2006+A1:2010 / EN 61000-6-4:2007+A1:2011)
Emitted radiation	Business and commercial areas as well as small enterprises (IEC 61000-6-8:2020 / EN IEC 61000-6-8:2020)
Electromagnetic immunity	Industrial environment (IEC 61000-6-2:2016 / EN IEC 61000-6-2:2019 / IEC 61000-6-2:2005 / EN 61000-6-2:2005 / EN 61000-6-2:2005/AC:2005)
Application areas	Automotive (UN ECE R10) <sup>1)</sup>
Application areas	Agricultural and forestry machinery (ISO 14982-1, ISO 14982-2) <sup>1) 2)</sup>

<sup>1)</sup> Load dump: from ISO 16750-2 Test B Severity Level 4 passed for 12 V systems. Required in case of transient disturbances on the input filtering signal lines (de-bounce > 10 ms).

<sup>2)</sup> The requirements of ISO 13766-1 and DIN EN ISO 14982-1 for immunity to electrostatic discharge (ESD) are only met in areas that can be easily touched from the outside.

<sup>3)</sup> IEC 60068-2-6:2007.

<sup>4)</sup> IEC 60068-2-64:2008.

<sup>5)</sup> IEC 60068-2-27:2008.

<sup>6)</sup> EN 60068-2-14:2009.

Application areas	Earthmoving and construction machinery (ISO 13766-1) <sup>1) 2)</sup>
<b>Vibration resistance</b>	
Sine resonance scan	10 Hz ... 1,000 Hz, 1 g <sup>3)</sup>
Sine test	10 Hz ... 500 Hz, 10 g, 10 frequency cycles <sup>3)</sup>
Noise test	10 Hz ... 500 Hz, 13.5 g RMS, 5 h <sup>4)</sup>
	Short restriction in measurement data availability possible during peak loads.
<b>Shock resistance</b>	
	100 g, 6 ms, ± 3 single shocks/axis <sup>5)</sup>
	40 g, 6 ms, ± 4,000 continuous shocks/axis <sup>5)</sup>
	50 g, 3 ms, ± 5,000 continuous shocks/axis <sup>5)</sup>
	Short restriction in measurement data availability possible.
<b>Ambient operating temperature</b>	-33 °C ... +50 °C
<b>Storage temperature</b>	-40 °C ... +70 °C
<b>Temperature change</b>	-33 °C ... +50 °C, 10 cycles <sup>6)</sup>
<b>Damp heat</b>	
Cyclical	+ 25 °C ... + 55 °C, 95 % RH, non-condensing (operation/storage/transport) (EN 60068-2-30)
Static	+ 40 °C, 93 % RH, non-condensing (operation) (EN 60068-2-78)
<b>Permissible relative humidity</b>	
Operation	< 80 %, Non-condensing (EN 60068-2-30:2005)
Storage	≤ 90 %, Non-condensing (EN 60068-2-30:2005)
<b>Ambient light immunity</b>	100 klx, indirect
<b>Altitude (above sea level)</b>	< 5,000 m

<sup>1)</sup> Load dump: from ISO 16750-2 Test B Severity Level 4 passed for 12 V systems. Required in case of transient disturbances on the input filtering signal lines (de-bounce > 10 ms).

<sup>2)</sup> The requirements of ISO 13766-1 and DIN EN ISO 14982-1 for immunity to electrostatic discharge (ESD) are only met in areas that can be easily touched from the outside.

<sup>3)</sup> IEC 60068-2-6:2007.

<sup>4)</sup> IEC 60068-2-64:2008.

<sup>5)</sup> IEC 60068-2-27:2008.

<sup>6)</sup> EN 60068-2-14:2009.

### General notes

<b>Note on use</b>	The sensor does not constitute a safety component as defined by relevant legislation on machine safety.
--------------------	---

### Classifications

<b>ECLASS 5.0</b>	27270990
<b>ECLASS 5.1.4</b>	27270990
<b>ECLASS 6.0</b>	27270913
<b>ECLASS 6.2</b>	27270913
<b>ECLASS 7.0</b>	27270913
<b>ECLASS 8.0</b>	27270913
<b>ECLASS 8.1</b>	27270913
<b>ECLASS 9.0</b>	27270913
<b>ECLASS 10.0</b>	27270913
<b>ECLASS 11.0</b>	27270913
<b>ECLASS 12.0</b>	27270913

<b>ETIM 5.0</b>	EC002550
<b>ETIM 6.0</b>	EC002550
<b>ETIM 7.0</b>	EC002550
<b>ETIM 8.0</b>	EC002550
<b>UNSPSC 16.0901</b>	41111615

### Dimensional drawing (Dimensions in mm (inch))

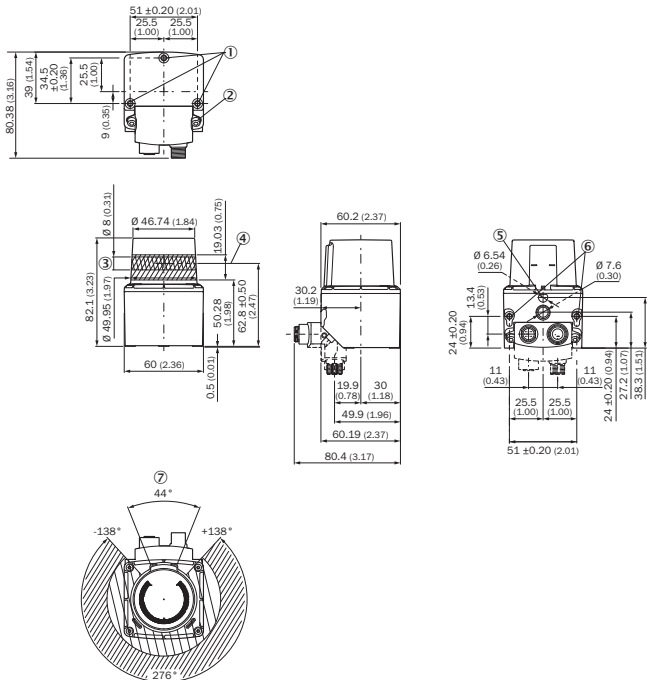

- ① M4 threaded mounting hole; 4.2 mm deep; tightening torque 2.5 nm
- ② Tightening torque 2.5 nm, screw included in plug unit
- ③ Sending area
- ④ Transmission axis
- ⑤ Support point
- ⑥ M4 threaded mounting hole; 5.4 mm deep, tightening torque 2.5 nm
- ⑦ Area in which no reflective surfaces are allowed for mounted devices

## Working range diagram

Working range for picoScan150 Pro-1

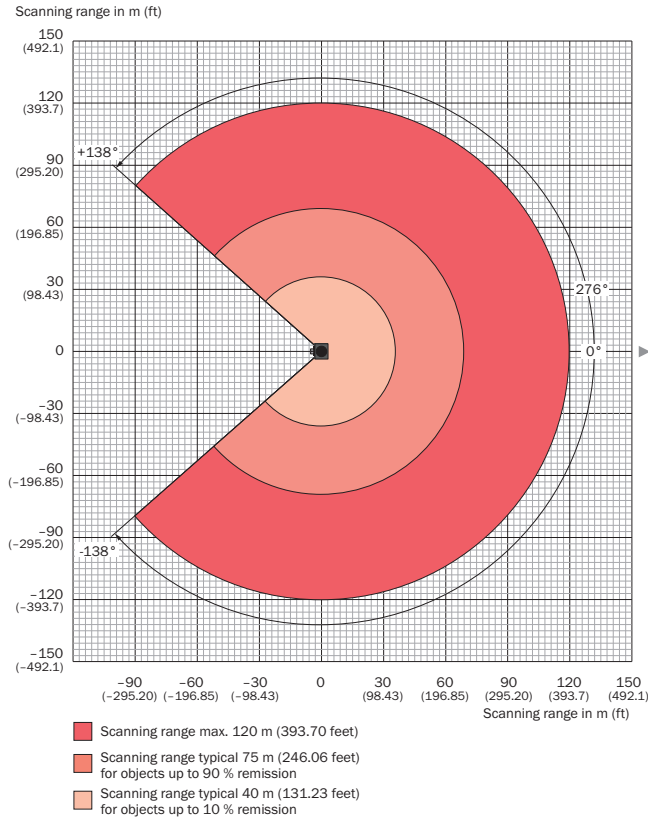

All specified working range values apply to the “Standard” sensitivity mode

Dynamic Sensing Profile	Minimum		Typical				On high reflective targets and reflectors	
	100 klx		10 klx		100 klx		W/o range extension	With range extension
	10 %	90 %	10 %	90 %	10 %	90 %		
<b>15 Hz &amp; 0.5°</b>	-	-	40 m	75 m	27 m	52 m	60 m	120 m
<b>15 Hz &amp; 0.33°</b>	-	-	40 m	75 m	27 m	52 m	60 m	120 m
<b>20 Hz &amp; 0.1°</b>	17 m	32 m	27 m	45 m	19 m	36 m	45 m	Not available
<b>20 Hz &amp; 0.25°</b>	-	-	34 m	65 m	24 m	45 m	60 m	120 m
<b>25 Hz &amp; 0.25°</b>	20 m	39 m	33 m	62 m	22 m	43 m	60 m	110 m
<b>30 Hz &amp; 0.1°</b>	-	-	25 m	30 m	17 m	30 m	30 m	Not available
<b>40 Hz &amp; 0.25°</b>	18 m	34 m	29 m	55 m	20 m	38 m	60 m	70 m
<b>50 Hz &amp; 0.25°</b>	-	-	27 m	52 m	19 m	36 m	55 m	Not available
<b>15 Hz &amp; 0.05°</b>	-	-	25 m	25 m	17 m	25 m	25 m	Not available
<b>40 Hz &amp; 0.125°</b>	-	-	24 m	25 m	17 m	30 m	30 m	Not available

### Recommended services

Additional services → [www.sick.com/picoScan100](http://www.sick.com/picoScan100)

	Type	Part no.
<b>Maintenance</b>		
<ul style="list-style-type: none"> <li>• <b>Product area:</b> 2D LiDAR sensors, 3D LiDAR sensors</li> <li>• <b>Range of services:</b> Inspection, analysis and restoring of defined functions, Inspection and adaptation of basic settings, parameters of field application, filters for raw data output, and product-specific configuration</li> <li>• <b>Duration:</b> Additional work will be invoiced separately</li> </ul>	Maintenance of LiDAR sensors	1682593
<b>Commissioning</b>		
<ul style="list-style-type: none"> <li>• <b>Product area:</b> 2D LiDAR sensors, 3D LiDAR sensors</li> <li>• <b>Range of services:</b> Inspection of connection, fine adjustment, configuration of monitored areas, configuration and optimization of parameters as well as tests, Setup of previously defined functions of basic settings, parameters of field application, filters for raw data output and product-specific configuration</li> <li>• <b>Duration:</b> Additional work will be invoiced separately</li> </ul>	Commissioning LiDAR sensors	1680672



## SICK AT A GLANCE

SICK is one of the leading manufacturers of intelligent sensors and sensor solutions for industrial applications. A unique range of products and services creates the perfect basis for controlling processes securely and efficiently, protecting individuals from accidents and preventing damage to the environment.

We have extensive experience in a wide range of industries and understand their processes and requirements. With intelligent sensors, we can deliver exactly what our customers need. In application centers in Europe, Asia and North America, system solutions are tested and optimized in accordance with customer specifications. All this makes us a reliable supplier and development partner.

Comprehensive services complete our offering: SICK LifeTime Services provide support throughout the machine life cycle and ensure safety and productivity.

For us, that is “Sensor Intelligence.”

## WORLDWIDE PRESENCE:

Contacts and other locations –[www.sick.com](http://www.sick.com)