



# SAPPB2D-08X0050

Safe Robotics Area Protection

SAFETY SYSTEMS FOR ROBOTS

**SICK**  
Sensor Intelligence.



### Ordering information

#### sBot Stop

Robot restart	Primary protective device (access control)	Secondary protective device (presence detection)	Type	Part no.
Automatic	Multiple light beam safety device deTem4 Core Number of beams: 4 Beam separation: 300 mm	Safety laser scanners microScan3 Core I/O Protective field range: 5.5 m	SAPPB2D-08X0050	1097911

**Included in delivery:** BEF-1SHABPKU4 (1), M4C-EA04300A10 (1), UE410-8DI4 (1), MICS3-AAZ55AZ1P01 (1), UE410-MU4T0 (1), M4C-SA0430LA10 (1)

This system variant enables an automatic restart of the robot.

Other models and accessories → [www.sick.com/Safe\\_Robotics\\_Area\\_Protection](http://www.sick.com/Safe_Robotics_Area_Protection)

### Detailed technical data

#### Features

<b>Variant</b>	sBot Stop
<b>Product type</b>	Hardware and logics
<b>Robot controller</b>	Generic
<b>Stopping process of the robot</b>	Stop only
<b>Robot restart</b>	Automatic
<b>Interfaces</b>	
Communication interface	Discrete I/Os
<b>Safe state in the event of a fault</b>	The safety-related semiconductor outputs are in the OFF state.
<b>Safety laser scanners</b>	microScan3 Core I/O
Protective field range	5.5 m
<b>Safety task</b>	Hazardous area protection
<b>Ambient operating temperature</b>	-10 °C ... +50 °C
<b>Storage temperature</b>	-20 °C ... +50 °C
<b>Air humidity</b>	90% at 50 °C (EN 61131-2)
<b>Safety sensors</b>	
Primary protective device (access control)	Safety multibeam sensors
Secondary protective device (presence detection)	Safety laser scanners
<b>Safety multibeam sensors</b>	deTem4 Core
Number of beams	4
Beam separation	300 mm
Scanning range	17 m
<b>Safety controller included</b>	Flexi Classic
Safety controller type	Non programmable

<b>Voltage supply</b>	Supply voltage $V_S$	24 V DC (16.8 V DC ... 28.8 V DC)
<b>Performance level</b>		PL d (ISO 13849-1)
<b>Items supplied</b>		microScan3 Core I/O safety laser scanner deTem4 Core multiple light beam safety device sender and receiver Flexi Classic main module UE410-MU4T0 Flexi Classic UE410-8DI4 module safety controller FlexFix brackets Documentation (operating instructions, SISTEMA file, wiring diagram)

Functions

<b>Emergency stop</b>		
Shut down in the event of an emergency situation	✓	
Prevent unexpected restarting after an emergency stop	✓	
<b>Initiate a safety stop</b>		
Automated reset	✓	
<b>Operating mode</b>		
Operating mode selection (implemented in robot control)	✓	

Classifications

<b>ECLASS 5.0</b>	27279090
<b>ECLASS 5.1.4</b>	27279090
<b>ECLASS 6.0</b>	27279090
<b>ECLASS 6.2</b>	27279090
<b>ECLASS 7.0</b>	27279090
<b>ECLASS 8.0</b>	27279090
<b>ECLASS 8.1</b>	27279090
<b>ECLASS 9.0</b>	27279090
<b>ECLASS 10.0</b>	27279090
<b>ECLASS 11.0</b>	27279090
<b>ECLASS 12.0</b>	27279090
<b>ETIM 5.0</b>	EC001449
<b>ETIM 6.0</b>	EC001449
<b>ETIM 7.0</b>	EC001449
<b>ETIM 8.0</b>	EC001449
<b>UNSPSC 16.0901</b>	32151705

### Dimensional drawing (Dimensions in mm (inch))

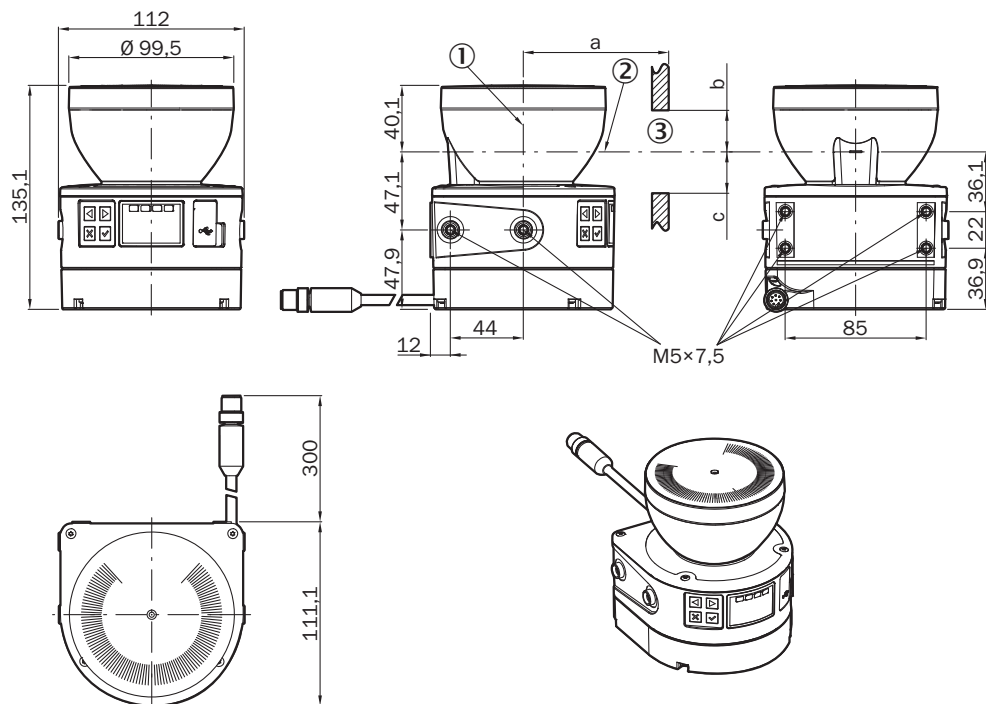

- ① Mirror axis of rotation
- ② Scan plane
- ③ Required viewing slit (a: length of the viewing slit, b: minimum height above the scan plane, c: minimum height below the scan plane. See the operating instructions for details.)

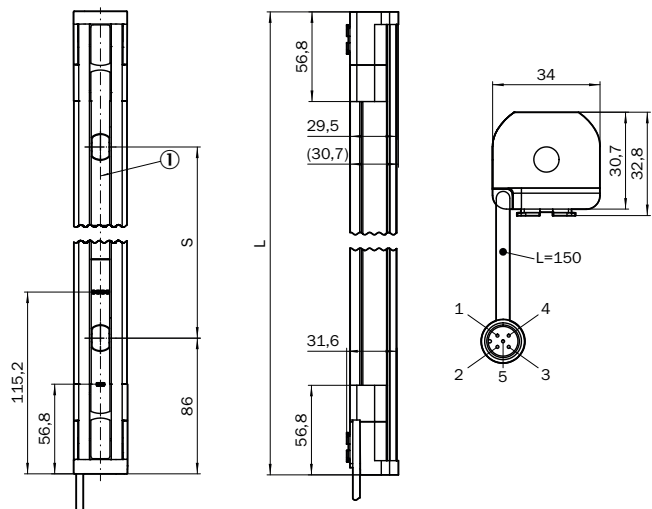

- ① Optical axis

Flexi Classic main module

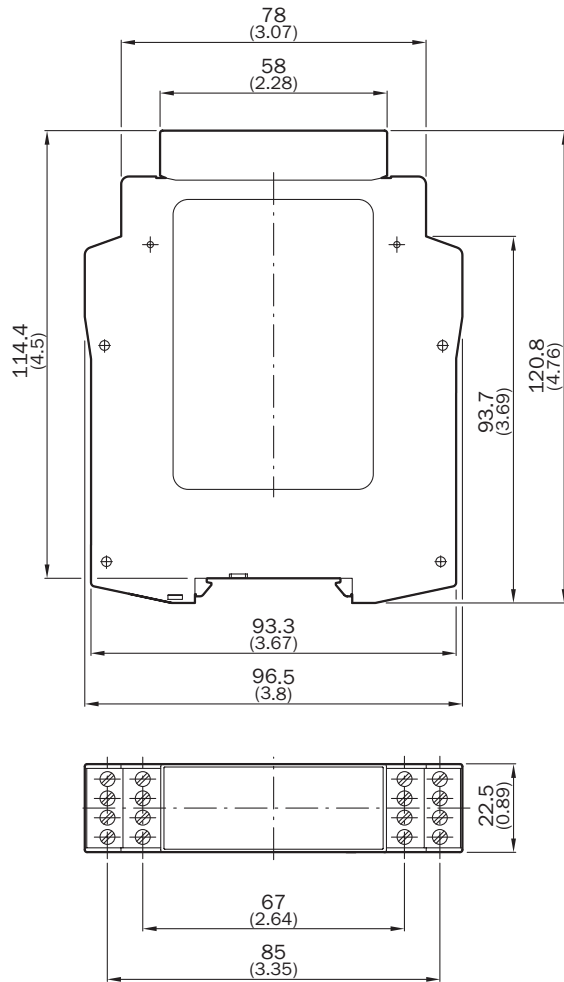

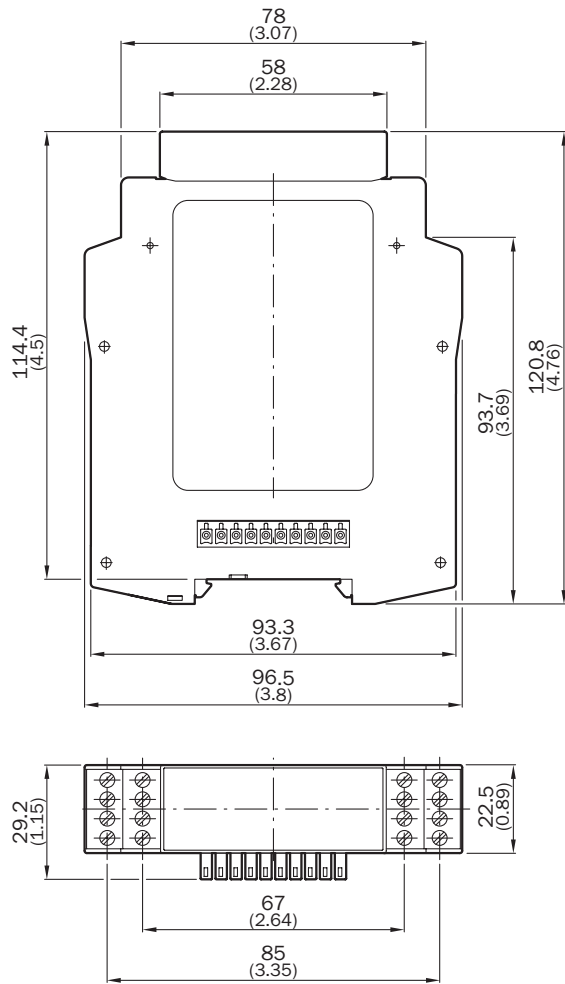

Number of beams	Beam separation S	Length L
2	500 (19.69)	672 (26.46)
3	400 (15.75)	972 (38.27)
4	300 (11.81)	1,072 (42.2)

## SICK AT A GLANCE

SICK is one of the leading manufacturers of intelligent sensors and sensor solutions for industrial applications. A unique range of products and services creates the perfect basis for controlling processes securely and efficiently, protecting individuals from accidents and preventing damage to the environment.

We have extensive experience in a wide range of industries and understand their processes and requirements. With intelligent sensors, we can deliver exactly what our customers need. In application centers in Europe, Asia and North America, system solutions are tested and optimized in accordance with customer specifications. All this makes us a reliable supplier and development partner.

Comprehensive services complete our offering: SICK LifeTime Services provide support throughout the machine life cycle and ensure safety and productivity.

For us, that is “Sensor Intelligence.”

## WORLDWIDE PRESENCE:

Contacts and other locations –[www.sick.com](http://www.sick.com)