



SBL-04D12-KC10

Passive distribution boxes

SICK
Sensor Intelligence.



Ordering information

Type	Part no.
SBL-04D12-KC10	6028395

Only suitable for PNP sensors

Other models and accessories → www.sick.com/Passive_distribution_boxes

Detailed technical data

Technical specifications

Number of slots	4
Slot connection type	M12
Connecting cable	10 m, 11-wire, PUR, halogen-free
Cable color	Black
Conductor cross section	0.5 mm ² 3 x 1.00 mm ² + 8 x 0.50 mm ²
Reference voltage	≤ 32 V
Current loading	11 A
Enclosure rating	IP67 ¹⁾
Items supplied	With 2 dust covers and 10 attachable labels

¹⁾ Only in fully locked position with its plugs.

Classifications

ECLASS 5.0	27279201
ECLASS 5.1.4	27279201
ECLASS 6.0	27279201
ECLASS 6.2	27279201
ECLASS 7.0	27279201
ECLASS 8.0	27279201
ECLASS 8.1	27279201
ECLASS 9.0	27440108
ECLASS 10.0	27440108
ECLASS 11.0	27440108
ECLASS 12.0	27440108
ETIM 5.0	EC002585
ETIM 6.0	EC002585
ETIM 7.0	EC002585
ETIM 8.0	EC002585
UNSPSC 16.0901	31163032

Dimensional drawing (Dimensions in mm (inch))

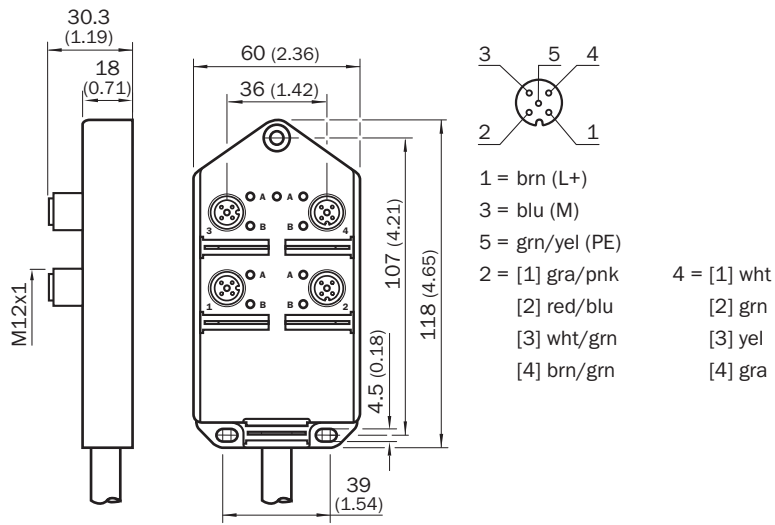

SICK AT A GLANCE

SICK is one of the leading manufacturers of intelligent sensors and sensor solutions for industrial applications. A unique range of products and services creates the perfect basis for controlling processes securely and efficiently, protecting individuals from accidents and preventing damage to the environment.

We have extensive experience in a wide range of industries and understand their processes and requirements. With intelligent sensors, we can deliver exactly what our customers need. In application centers in Europe, Asia and North America, system solutions are tested and optimized in accordance with customer specifications. All this makes us a reliable supplier and development partner.

Comprehensive services complete our offering: SICK LifeTime Services provide support throughout the machine life cycle and ensure safety and productivity.

For us, that is “Sensor Intelligence.”

WORLDWIDE PRESENCE:

Contacts and other locations –www.sick.com