



STS084-HN084-AK22

STS

MOTOR FEEDBACK SYSTEMS

SICK
Sensor Intelligence.



Illustration may differ



Ordering information

Type	Part no.
STS084-HN084-AK22	1121159

Mounting screws not included with delivery.

Other models and accessories → www.sick.com/STS

Detailed technical data

Features

Items supplied	Magnetic tape not included with delivery, Mounting screws not included with delivery.
-----------------------	---

Safety-related parameters

MTTF_D (mean time to dangerous failure)	190 years (EN ISO 13849) ¹⁾
--	--

¹⁾ This product is a standard product and does not constitute a safety component as defined in the Machinery Directive. Calculation based on nominal load of components, average ambient temperature 60 °C, frequency of use 8760 h/a. All electronic failures are considered hazardous. For more information, see document no. 8015532.

Performance

Sine/cosine periods per revolution	158
Number of the absolute ascertainable revolutions	1
Total number of steps	5,056 via RS485
Measuring step	2 " For interpolation of the sine/cosine signals with, e. g., 12 bits
Available memory area	1,792 Byte
System accuracy	± 0.054 ° ¹⁾
Repeatability	0.01 °, Typical values for mechanical runout of the system from ≤ 50 µm and +20 °C
Pin length	2 mm

¹⁾ Typical values for mechanical runout of the system from ≤ 50 µm and +20 °C.

Interfaces

Type of code for the absolute value	Binary
Code sequence	Increasing, when turning the shaft For clockwise rotation, looking in direction "A" (see dimensional drawing)
Communication interface	HIPERFACE®

Electrical data

Connection type	Male connector, 8-pin
------------------------	-----------------------

¹⁾ Without load.

Supply voltage	7 V DC ... 12 V DC
Recommended supply voltage	8 V DC
Current consumption	250 mA ¹⁾

¹⁾ Without load.

Mechanical data

Shaft version	Through hollow shaft
Material, sensor head	Aluminum
Material, magnetic tape	17410 Hard ferrite 9/28 P
Material, ring	Aluminum
Dimensions	See dimensional drawing
Weight	≤ 0.15 kg (sensor head) ≤ 0.75 kg (Magnetic tape ring)
Moment of inertia of the rotor	1.525 gcm ²
Operating speed	4,700 min ⁻¹
Angular acceleration	≤ 50,000 rad/s ²
Permissible radial shaft movement	≤ 0.6 mm ¹⁾
Permissible axial shaft movement	± 0.5 mm ¹⁾

¹⁾ Relative to the installation position, as described in the assembly instructions (order nr. 8026831) and in the proposed customer fitting.

Ambient data

Operating temperature range	-30 °C ... +105 °C, sensor head -30 °C ... +100 °C, Magnetic tape ring
Storage temperature range	-30 °C ... +100 °C, without package
Relative humidity/condensation	95 %, Condensation not permitted
Resistance to shocks	100 g, 6 ms (according to EN 60068-2-27)
Frequency range of resistance to vibrations	20 g, 10 Hz ... 2,000 Hz (EN 60068-2-6)
EMC	According to EN 61000-6-2 and EN 61000-6-4 ¹⁾
Enclosure rating	IP00
Temperature coefficient magnetic tape	(11 ± 1) µm/K/m
Maximum permitted ambient field strength	< 3 kA/m ... 4 kA/m (3.8 mT ... 5 mT), to guarantee compliance with the quoted accuracy values ²⁾
Maximum permitted field strength	< 150 kA/m (< 190 mT), to ensure that the magnetic tape is not permanently damaged

¹⁾ The EMC according to the standards quoted is achieved when the motor feedback system is mounted in an electrically conductive housing, which is connected to the central earthing point of the motor controller via a cable screen. Please observe the information in the mounting instructions (part number 8026831).

²⁾ The maximum permitted external field influence is reached when the position value deviates from the original value (without external field influence) by more than 5 µm. This value is reached when, at the sensor location, a field strength of 3 kA/m to 4 kA/m (3.8 mT to 5 mT) occurs in addition to the field strength of the magnetic tape.

Classifications

ECLASS 5.0	27270590
ECLASS 5.1.4	27270590
ECLASS 6.0	27270590
ECLASS 6.2	27270590
ECLASS 7.0	27270590

ECLASS 8.0	27270590
ECLASS 8.1	27270590
ECLASS 9.0	27270590
ECLASS 10.0	27273805
ECLASS 11.0	27273901
ECLASS 12.0	27273901
ETIM 5.0	EC001486
ETIM 6.0	EC001486
ETIM 7.0	EC001486
ETIM 8.0	EC001486
UNSPSC 16.0901	41112113

Dimensional drawing (Dimensions in mm (inch))

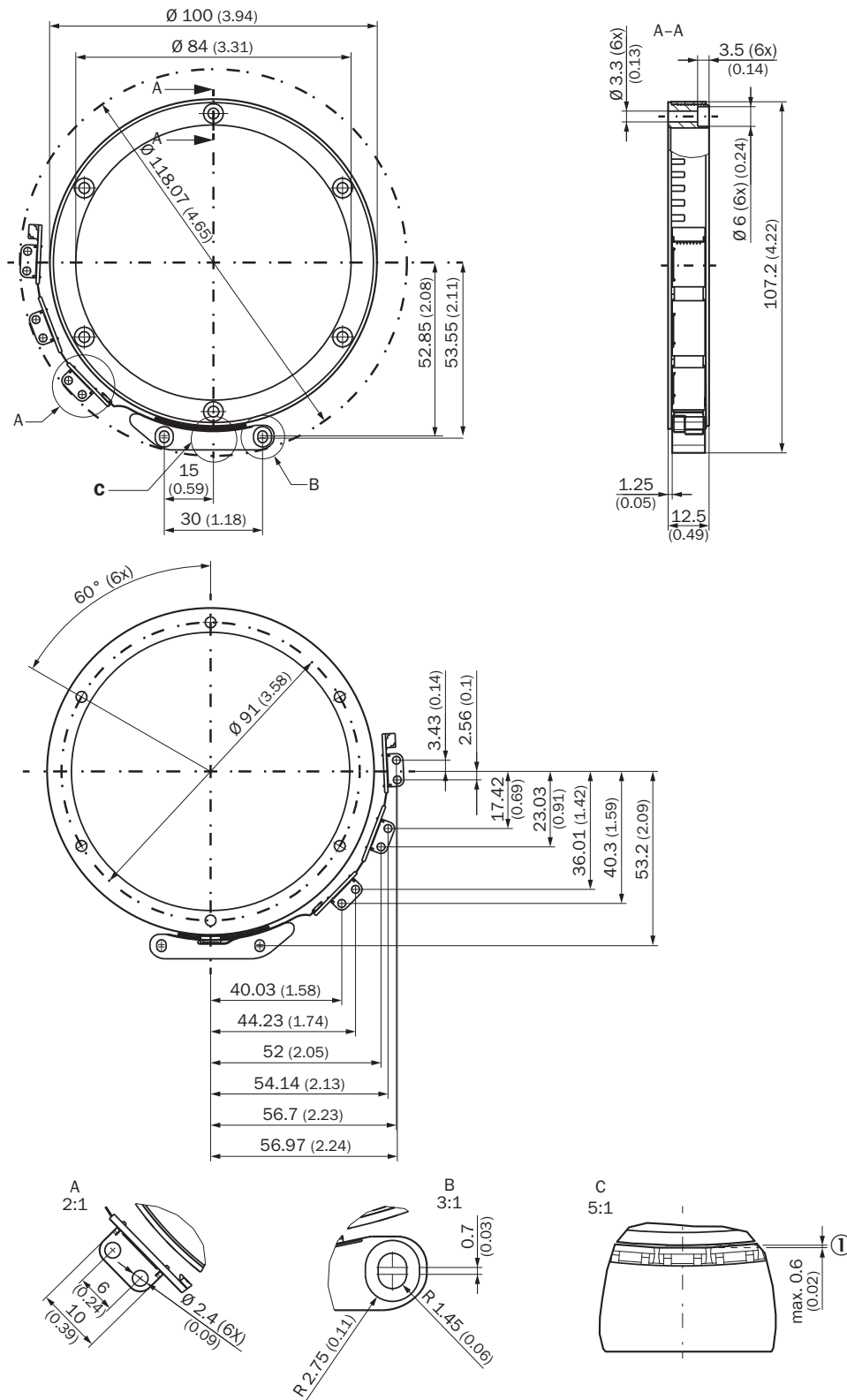

① Distance between sensor head and magnetic ring

Attachment specifications

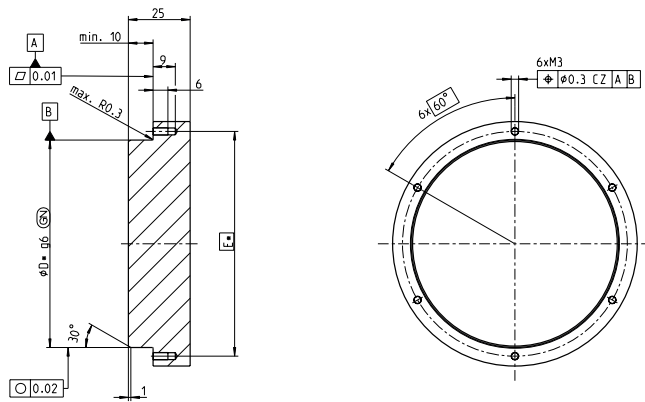

Type	Ø D	Ø E
STS030	30 mm	36 mm
STS065	65 mm	72 mm
STS084	84 mm	91 mm

PIN assignment

View of the plug-in face

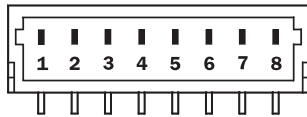

PIN	Signal	Wire colors (cable connection)	Explanation
1	U _S	Red	Supply voltage
2	+ SIN	White	Process data channel
3	REFSIN	Brown	Process data channel
4	+ COS	Pink	Process data channel
5	REFCOS	Black	Process data channel
6	GND	Blue	Ground connection
7	Data +	Gray or yellow	Parameter channel RS 485
8	Data -	Green or purple	Parameter channel RS 485

The GND connection (0 V) of the supply voltage is not connected to the housing

Position tolerance

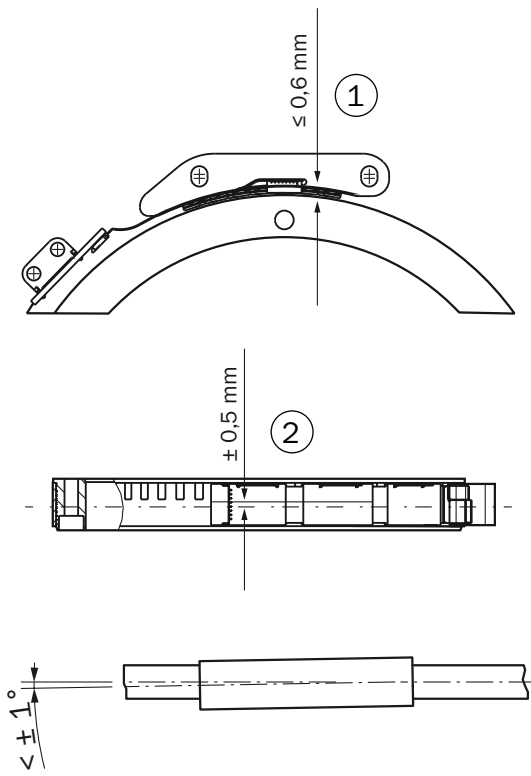

- ① Distance between sensor head and magnetic ring
- ② Axial tolerances

Operation note

Overview of supported commands for HIPERFACE®

Command byte	Function	Comments
42h	Read position	
43h	Set position	
44h	Read analog value	
		Channel number 48h - Temperature in °C F0h - Temperature compatible to product families SCx °C * 2,048 - 40
46h	Read counter	
47h	Increment Counter	
49h	Delete counter	
4Ah	Read data	
4Bh	Store data	
4Ch	Determine status of a data field	
4Dh	Create data field	
4Eh	Determine available memory area	
4Fh	Change access code	
50h	Read encoder status	
52h	Read out type label	Encoder type = FFh
53h	Encoder reset	
55h	Allocate encoder address	
56h	Read serial number and program version	
6Ch	Read Synchronization Offset	

Overview of warnings and fault indications

	Status code	Description
Error type	00h	The encoder has not detected any faults
Initialization	01h	Incorrect alignment data
	02h	Incorrect internal angular offset
	03h	Data field partitioning table destroyed
	04h	Analog limit values not available
	05h	Internal I2C bus inoperative
	06h	Internal checksum error
Protocol	07h	Encoder reset occurred as a result of program monitoring
	09h	Parity error
	0Ah	Checksum of transmitted data is incorrect
	0Bh	Unknown command code
	0Ch	Number of transmitted data is incorrect
	0Dh	Transmitted command argument is not allowed
Data	0Eh	The selected data field may not be written to
	0Fh	Incorrect access code
	10h	Size of specified data field cannot be changed
	11h	Specified word address lies outside the data field
Position	12h	Access to non-existent data field
	01h	Analog signals outside specification
	1Fh	Speed too high, no position formation possible
Other	20h	Singleturn position unreliable
	1Ch	Value monitoring of the analog signals (process data)
	1Dh	Transmitter current critical or P2RAM-Error
	1Eh	Encoder temperature critical
	08h	Counter overflow

For more information on the interface see HIPERFACE® - description, part no. 8010701

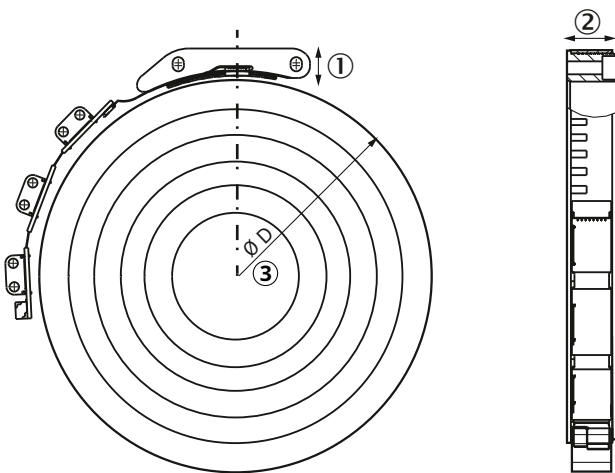

- ① Height 10 mm
- ② Encoder width 12. mm
- ③ Magnet ring sizes

Parameter	Inner diameter
D1	30 mm
D4	65 mm
D5	84 mm
Dx	Weitere Ringgrößen auf Anfrage

SICK AT A GLANCE

SICK is one of the leading manufacturers of intelligent sensors and sensor solutions for industrial applications. A unique range of products and services creates the perfect basis for controlling processes securely and efficiently, protecting individuals from accidents and preventing damage to the environment.

We have extensive experience in a wide range of industries and understand their processes and requirements. With intelligent sensors, we can deliver exactly what our customers need. In application centers in Europe, Asia and North America, system solutions are tested and optimized in accordance with customer specifications. All this makes us a reliable supplier and development partner.

Comprehensive services complete our offering: SICK LifeTime Services provide support throughout the machine life cycle and ensure safety and productivity.

For us, that is “Sensor Intelligence.”

WORLDWIDE PRESENCE:

Contacts and other locations –www.sick.com