



SYS/BOT-URSP4ESUA02NS3

Safe Robotics Area Protection

SAFETY SYSTEMS FOR ROBOTS

SICK
Sensor Intelligence.



Ordering information

sBot Speed

Robot restart	Safety laser scanner included	Protective field range	Product type	Type	Part no.
Automatic	nanoScan3 Pro I/O	3 m	System (hardware and software)	SYS/BOT-URSP4ESUA02NS3	1137605

The safety system, comprising hardware, software and documentation, makes it easy to configure a safety application with a UR robot (the robot is not supplied with the system).

With purchase, you accept the product description available under Downloads > Documentation in connection with the General Terms and Conditions for the Supply of Software Products (AVB Software SICK).

Other models and accessories → www.sick.com/Safe_Robotics_Area_Protection

Detailed technical data

Features

Variant	sBot Speed2 – URCap
Description	sBot Speed2 - URCap is a safety system for UR robots that makes it easy to protect your freely accessible robot application. The system reduces downtimes thanks to the reduction in speed of the robot according to the specific position of the worker, and the option of automatic restart. Thanks to the two nanoScan3 safety laser scanners, approaching persons are detected over a 360-degree range. Using the nanoScan3 Tool - URCap, the safety laser scanner can be configured quickly and easily directly via the teach pendant of the robot.
Product type	System (hardware and software)
Robot controller	Universal Robots: UR3e, UR5e, UR10e, UR16e, UR20 und UR30
Compatible robot software	Polyscope 5
Stopping process of the robot	With speed reduction
Robot restart	Automatic
Interfaces	
Communication interface	Discrete I/Os
Configuration interface	Ethernet
Safe state in the event of a fault	The safety-related semiconductor outputs are in the OFF state.
Safety laser scanners	nanoScan3 Pro I/O
Protective field range	3 m
Safety task	Hazardous area protection
Ambient operating temperature	-10 °C ... +50 °C
Storage temperature	-25 °C ... +70 °C
Air humidity	0% ... 95%, non-condensing
Voltage supply	
Supply voltage V_S	24 V DC (19.2 V DC ... 30 V DC)
Performance level	PL d (ISO 13849-1)
Items supplied	2 x nanoScan3 Pro I/O safety laser scanners 2 x system plug 2 x mounting kit (with protection for optics cover)

	2 x Ethernet cable, 5 m 2 x M12 connecting cable, 10 m, flying leads 1 x main module for Flexi Classic safety controller 1 x Flexi Classic extension module nanoScan3 Tool - URCap (configuration software) Operating instructions Quickstart guide Circuit diagram(macro for ePlan and PDF) SISTEMA file
--	---

Functions

Initiate a safety stop	
Automated reset	✓
Safety-rated monitored speed	
Trigger safety-rated monitored speed	✓
Operating mode	
Operating mode selection (implemented in robot control)	✓
Enabling device - manual operating mode (implemented in robot control)	✓

Classifications

ECLASS 5.0	27279090
ECLASS 5.1.4	27279090
ECLASS 6.0	27279090
ECLASS 6.2	27279090
ECLASS 7.0	27279090
ECLASS 8.0	27279090
ECLASS 8.1	27279090
ECLASS 9.0	27279090
ECLASS 10.0	27279090
ECLASS 11.0	27279090
ECLASS 12.0	27279090
ETIM 5.0	EC001449
ETIM 6.0	EC001449
ETIM 7.0	EC001449
ETIM 8.0	EC001449
UNSPSC 16.0901	32151705

Dimensional drawing (Dimensions in mm (inch))

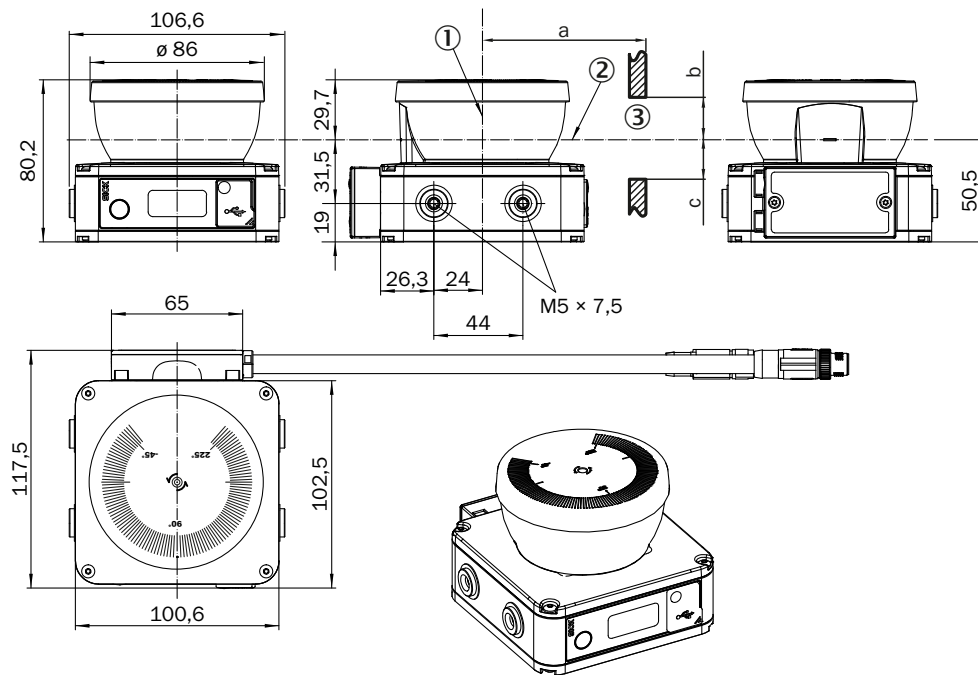

- ① Mirror axis of rotation
- ② Scan plane
- ③ Required viewing slit (a: length of the viewing slit, b: minimum height above the scan plane, c: minimum height below the scan plane. See the operating instructions for details.)

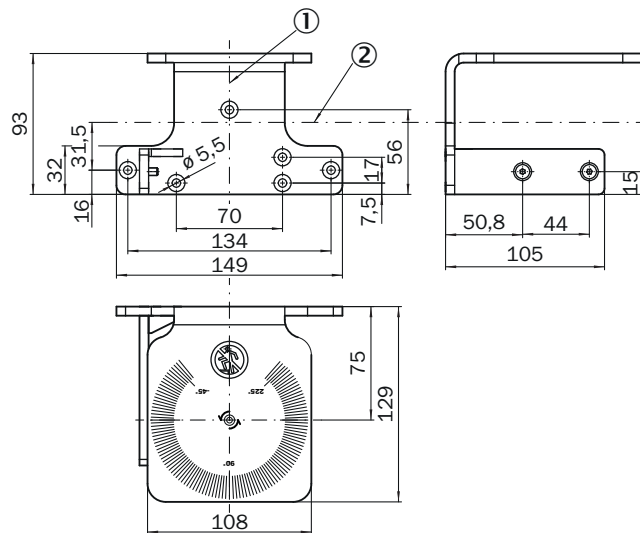

- ① Mirror axis of rotation
- ② Scan plane

Flexi Classic main module

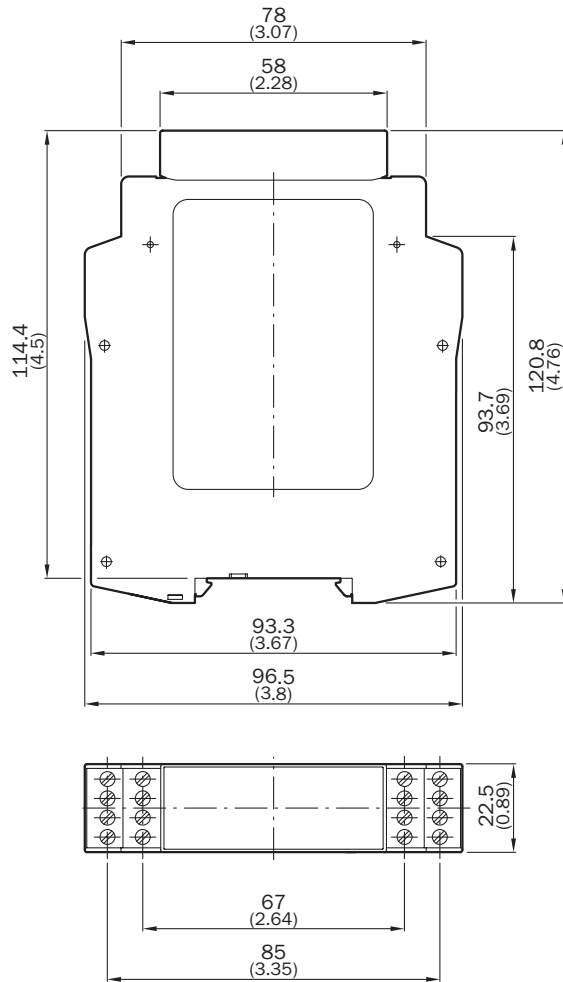

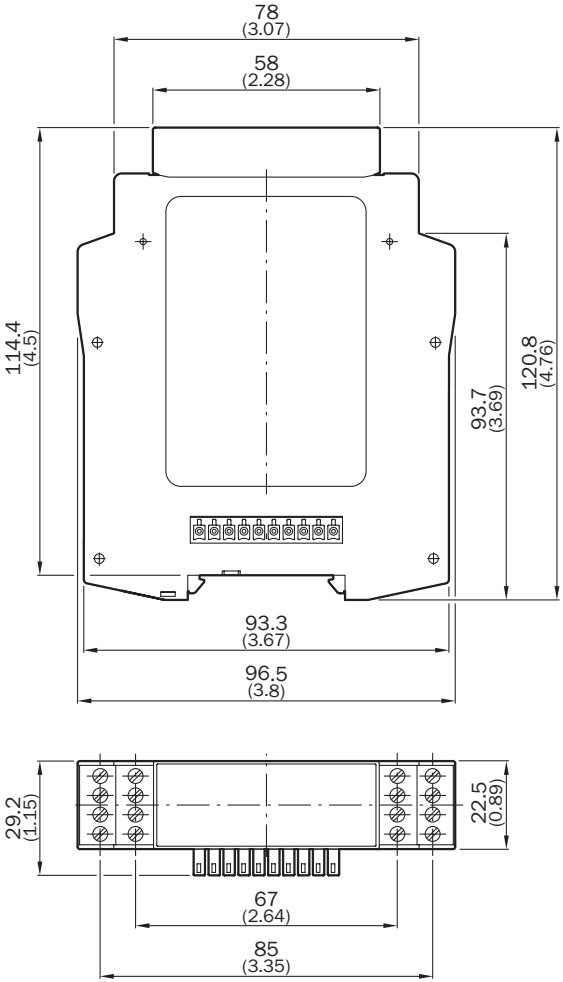

SICK AT A GLANCE

SICK is one of the leading manufacturers of intelligent sensors and sensor solutions for industrial applications. A unique range of products and services creates the perfect basis for controlling processes securely and efficiently, protecting individuals from accidents and preventing damage to the environment.

We have extensive experience in a wide range of industries and understand their processes and requirements. With intelligent sensors, we can deliver exactly what our customers need. In application centers in Europe, Asia and North America, system solutions are tested and optimized in accordance with customer specifications. All this makes us a reliable supplier and development partner.

Comprehensive services complete our offering: SICK LifeTime Services provide support throughout the machine life cycle and ensure safety and productivity.

For us, that is “Sensor Intelligence.”

WORLDWIDE PRESENCE:

Contacts and other locations –www.sick.com