



SYS/BOT-YASP4020101MS3

Safe Robotics Area Protection

SAFETY SYSTEMS FOR ROBOTS

SICK
Sensor Intelligence.



Ordering information

sBot Speed

Safety controller included	Safety laser scanner included	Protective field range	Product type	Type	Part no.
Flexi Soft (CPU0)	microScan3 Core I/O	5.5 m	System (hardware and software)	SYS/BOT-YASP4020101MS3	1117273

Included in delivery: FX3-MPL000001 (1), SAPPB2D-08XS006 (1), UE410-4R04 (2), FX3-CPU000000 (1), FX3-XTIO84002 (2), MICS3-AAAZ55AZ1P01 (1)

With purchase, you accept the product description available under Downloads > Documentation in connection with the General Terms and Conditions for the Supply of Software Products (AVB Software SICK).

Other models and accessories → www.sick.com/Safe_Robotics_Area_Protection

Detailed technical data

Features

Variant	sBot Speed – YA
Product type	System (hardware and software)
Robot controller	Yaskawa: DX200, YRC1000, YRC1000micro
Stopping process of the robot	With speed reduction
Robot restart	Automatic
Interfaces	
Communication interface	Discrete I/Os
Safe state in the event of a fault	The safety-related semiconductor outputs are in the OFF state.
Safety laser scanners	microScan3 Core I/O
Protective field range	5.5 m
Safety task	Hazardous area protection
Ambient operating temperature	-10 °C ... +50 °C
Storage temperature	-20 °C ... +50 °C
Air humidity	90% at 50 °C (EN 61131-2)
Safety controller included	Flexi Soft (CPU0)
Safety controller type	Programmable
Voltage supply	
Voltage supply connection type	An external voltage supply is required for the system. The external voltage supply must be capable of buffering brief mains voltage failures of 20 ms as specified in IEC 60204-1. Suitable power supplies are available as accessories from SICK.
Supply voltage V_S	24 V DC (16.8 V DC ... 28.8 V DC)
Performance level	PL d (ISO 13849-1)
Items supplied	microScan3 Core I/O safety laser scanner Flexi Soft main module FX3-CPU0 FX3-MPLO Flexi Soft system plug 2 x FX3-XTIO Flexi Soft I/O module 2 x Flexi Soft UE410-4R04 relay modules

	Software (Safety Designer project file with functional logic, pre-configuration file for microScan3 Core I/O, Yaskawa-specific settings, operating instructions, connection diagram and SISTEMA file)
--	---

Functions

Emergency stop	
Shut down in the event of an emergency situation	✓
Prevent unexpected restarting after an emergency stop	✓
Initiate a safety stop	
Automated reset and restart with safe sequence monitoring	✓
Safety-rated monitored speed	
Trigger safety-rated monitored speed	✓
Switch field sets	✓
Operating mode	
Operating mode selection (implemented in robot control)	✓
Enabling device - manual operating mode (implemented in robot control)	✓

Classifications

ECLASS 5.0	27279090
ECLASS 5.1.4	27279090
ECLASS 6.0	27279090
ECLASS 6.2	27279090
ECLASS 7.0	27279090
ECLASS 8.0	27279090
ECLASS 8.1	27279090
ECLASS 9.0	27279090
ECLASS 10.0	27279090
ECLASS 11.0	27279090
ECLASS 12.0	27279090
ETIM 5.0	EC001449
ETIM 6.0	EC001449
ETIM 7.0	EC001449
ETIM 8.0	EC001449
UNSPSC 16.0901	32151705

Dimensional drawing (Dimensions in mm (inch))

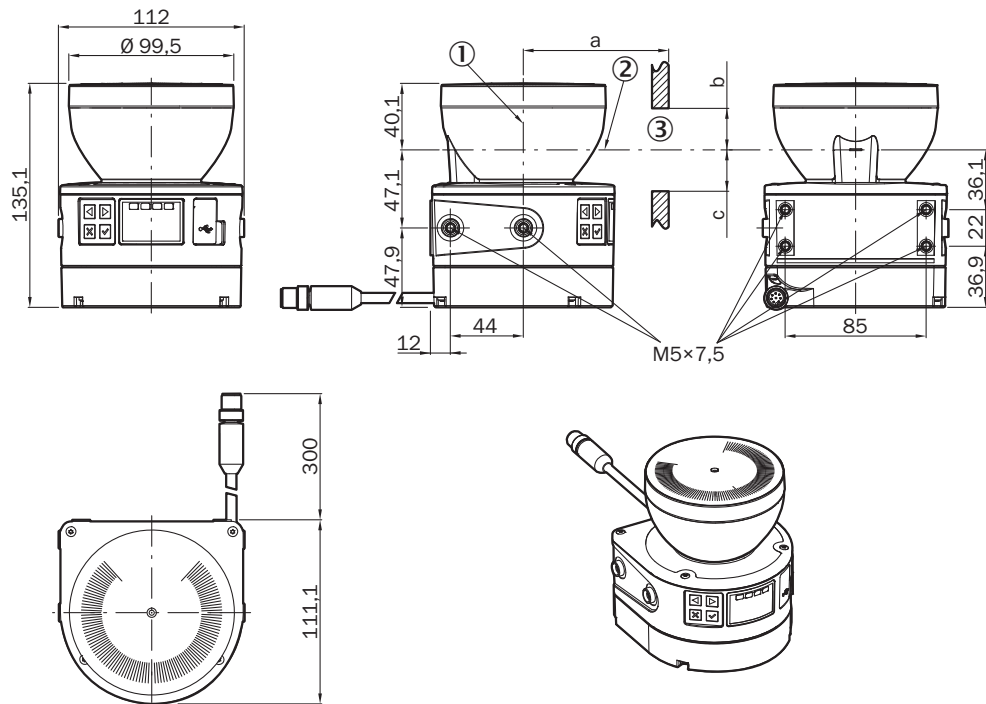

- ① Mirror axis of rotation
- ② Scan plane
- ③ Required viewing slit (a: length of the viewing slit, b: minimum height above the scan plane, c: minimum height below the scan plane. See the operating instructions for details.)

FX3-XTIO, FX3-XTDI

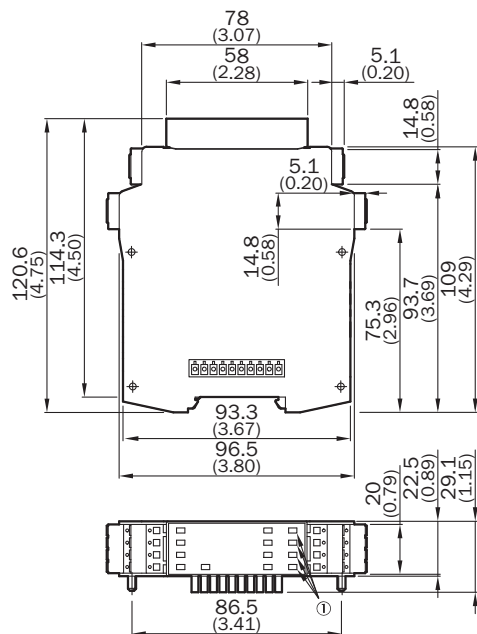

- ① Only valid for FX3-XTIO

FX3-CPU0

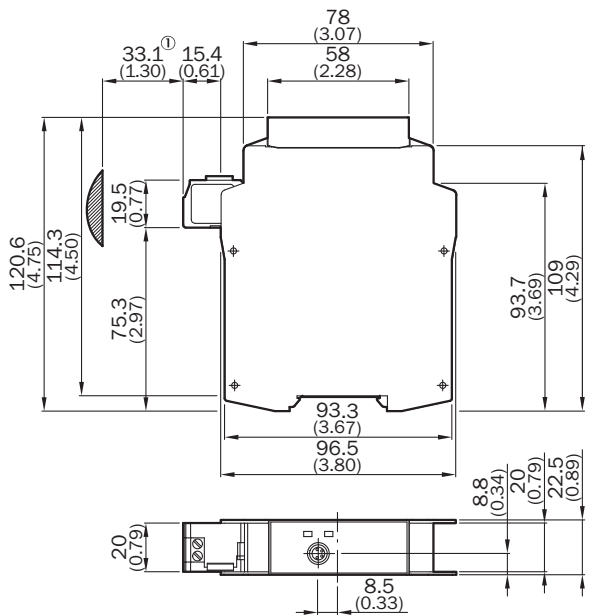

① Approximate connector range

SICK AT A GLANCE

SICK is one of the leading manufacturers of intelligent sensors and sensor solutions for industrial applications. A unique range of products and services creates the perfect basis for controlling processes securely and efficiently, protecting individuals from accidents and preventing damage to the environment.

We have extensive experience in a wide range of industries and understand their processes and requirements. With intelligent sensors, we can deliver exactly what our customers need. In application centers in Europe, Asia and North America, system solutions are tested and optimized in accordance with customer specifications. All this makes us a reliable supplier and development partner.

Comprehensive services complete our offering: SICK LifeTime Services provide support throughout the machine life cycle and ensure safety and productivity.

For us, that is “Sensor Intelligence.”

WORLDWIDE PRESENCE:

Contacts and other locations –www.sick.com