



## TPCC cooling housing DS500/DT500

**SICK**  
Sensor Intelligence.



## Ordering information

Type	Part no.
TPCC cooling housing DS500/DT500	6036182

Other models and accessories → [www.sick.com/](http://www.sick.com/)

## Product description

The TPCC cooling jacket works using the Peltier effect, making it possible to operate sensors permanently at ambient temperatures of +75 °C. In addition, the TPCC is able to significantly increase the service life of sensors. Due to physical constraints, the service life of a laser sensor halves for each 10 °C increase in temperature. The TPCC offers optimal sensor protection, reduces unexpected failures and associated system downtime for applications in hot environments, regardless of whether it is location or process-related. Its consistently long service life goes hand-in-hand with reducing replacement costs and production standstills. The innovative TPCC protects sensors, increases productivity and saves money.

## At a glance

- Efficient protection for sensors at increased ambient temperatures
- Maintenance-free Peltier cooling system
- Rugged polyamide 6 housing with front screen protection
- Thermostatic internal temperature control
- Temperature monitoring with automated cut-off in the event of excess temperatures
- Alignment bracket for easy mounting

## Your benefits

- Active sensor cooling through the Peltier effect extends the service life of up to 15% at 25 °C ambient temperature and up to 400% at 45 °C. Less frequent sensor exchange significantly reduces operational costs.
- Increased sensor reliability reduces unexpected failure and associated system downtime. This effectively lowers costs associated with system breakdowns and increases productivity.
- Consistent internal temperatures guarantee high accuracy of the measured values for precise measurement results.
- Electric Peltier cooling is maintenance-free and only requires a 24 V connection instead of complex water or air system.
-

Detailed technical data

Technical specifications

<b>Accessory group</b>	Heating and cooling devices
<b>Accessory family</b>	Cooler housing
<b>Description</b>	Cooler housing, Peltier cooling unit, polyamide 6 housing
<b>Weight</b>	+ 7.5 kg
<b>Enclosure rating</b>	IP55 (horizontal mounting) / IP54 (vertical mounting)
<b>Operating voltage</b>	24 V DC ... 30 V DC
<b>Power consumption</b>	At 24 V DC 1.1 A <sup>1)</sup>
<b>Ambient operating temperature</b>	-40 °C ... +75 °C
<b>Storage temperature</b>	-40 °C ... +50 °C

<sup>1)</sup> Start-up current max. 1.5 A at 24 V DC.

Classifications

<b>ECLASS 5.0</b>	27279290
<b>ECLASS 5.1.4</b>	27279290
<b>ECLASS 6.0</b>	27279290
<b>ECLASS 6.2</b>	27279290
<b>ECLASS 7.0</b>	27279290
<b>ECLASS 8.0</b>	27279290
<b>ECLASS 8.1</b>	27279290
<b>ECLASS 9.0</b>	27279090
<b>ECLASS 10.0</b>	27279090
<b>ECLASS 11.0</b>	27279090
<b>ECLASS 12.0</b>	27279090
<b>ETIM 5.0</b>	EC002594
<b>ETIM 6.0</b>	EC002594
<b>ETIM 7.0</b>	EC002594
<b>ETIM 8.0</b>	EC002594
<b>UNSPSC 16.0901</b>	32131001

## Dimensional drawing (Dimensions in mm (inch))

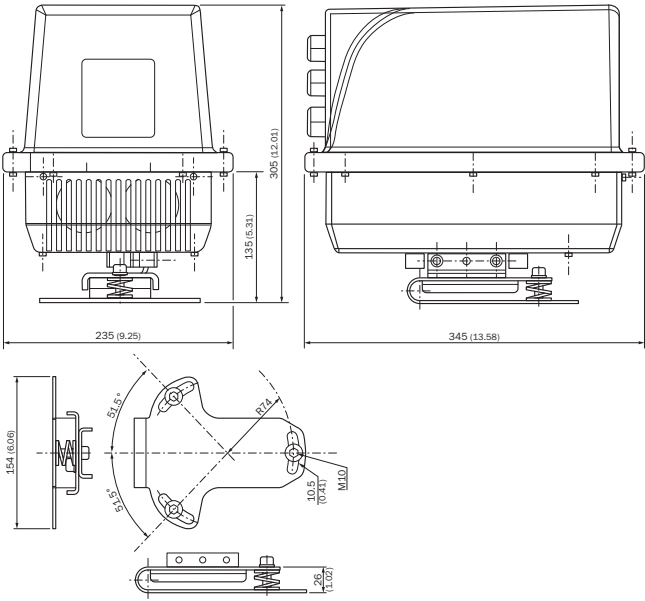

## SICK AT A GLANCE

SICK is one of the leading manufacturers of intelligent sensors and sensor solutions for industrial applications. A unique range of products and services creates the perfect basis for controlling processes securely and efficiently, protecting individuals from accidents and preventing damage to the environment.

We have extensive experience in a wide range of industries and understand their processes and requirements. With intelligent sensors, we can deliver exactly what our customers need. In application centers in Europe, Asia and North America, system solutions are tested and optimized in accordance with customer specifications. All this makes us a reliable supplier and development partner.

Comprehensive services complete our offering: SICK LifeTime Services provide support throughout the machine life cycle and ensure safety and productivity.

For us, that is “Sensor Intelligence.”

## WORLDWIDE PRESENCE:

Contacts and other locations –[www.sick.com](http://www.sick.com)