



# V2D8509R-1MCXXXALOSXXXX

Lector85x

IMAGE-BASED CODE READERS

**SICK**  
Sensor Intelligence.



### Ordering information

Type	Part no.
V2D8509R-1MCXXXALOSXXX	1130539

Other models and accessories → [www.sick.com/Lector85x](http://www.sick.com/Lector85x)

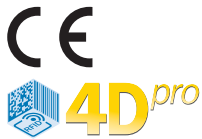

### Detailed technical data

#### Features

<b>Application</b>	Indoor area
<b>Variant</b>	Main unit
<b>Optical focus</b>	Adjustable focus (manually)
<b>Sensor</b>	CMOS matrix sensor, grayscale values
<b>Sensor resolution</b>	4,096 px x 2,176 px (9 Mpixel)
<b>Illumination</b>	To be ordered separately as accessories
<b>Feedback spot</b>	LED, Visible, green, 525 nm, ± 15 nm LED, Visible, Red, 645 nm, ± 15 nm
<b>Alignment aid</b>	Laser, Red, 630 nm ... 680 nm
<b>Laser class</b>	1, complies with 21 CFR 1040.10 except for the conformance according to "Laser Notice No. 56" from May 8, 2019 (EN 60825-1:2014+A11:2021, IEC 60825-1:2014)
<b>Lens</b>	C-mount
Optical format	1"
Focal length	12 mm, 16 mm, 25 mm
Note	To be ordered separately as accessories
<b>Scanning frequency</b>	20 Hz, With resolution of 9 megapixels
<b>Code resolution</b>	≥ 0.1 mm <sup>1)</sup>
<b>Working range</b>	500 mm ... 3,000 mm (depends on lens used)

<sup>1)</sup> Depends on lens used.

#### Mechanics/electronics

<b>Connection type</b>	1 x M12, 17-pin male connector, A-coded (power, CAN, serial interface, I/O) 1 x M12, 5-pin male connector, A-coded (power, CAN) 3 x M12, 8-pin female connector, X-coded (Gigabit Ethernet)
<b>Supply voltage</b>	24 V DC, ± 20 % <sup>1)</sup>

<sup>1)</sup> Voltage source in accordance with ES1 (EN 62368-1) or SELV (EN 60950-1).

<b>Power consumption</b>	Typ. 24 W
<b>Current consumption</b>	Max. 2 A
<b>Housing material</b>	Aluminum die cast
<b>Housing color</b>	Anthracite gray (RAL 7016)
<b>Window material</b>	Glass
<b>Enclosure rating</b>	IP65 (IEC 60529:2013 +C1:2013 +C2:2015 +AMD2 C1:2019, EN 60529:1991 +A1:2010 +A2:2013 +AC:2019-02)
<b>Electrical safety</b>	EN 61010:2010 / EN 61010-1:2010/A1:2019/AC:2019-04
<b>Weight</b>	640 g, without lens and connection cables
<b>Dimensions (L x W x H)</b>	143.4 mm x 90 mm x 46 mm
<b>MTBF</b>	100,000 h

<sup>1)</sup> Voltage source in accordance with ES1 (EN 62368-1) or SELV (EN 60950-1).

## Performance

<b>Readable code structures</b>	1D codes, 2D codes, Stacked
<b>Bar code types</b>	GS1-128 / EAN 128, UPC / GTIN / EAN, Interleaved 2 of 5, Code 39, Code 128, Codabar, Code 93
<b>2D code types</b>	Data Matrix ECC200, MaxiCode, QR code, Aztec
<b>Stacked code types</b>	PDF417

## Interfaces

<b>Ethernet</b>	✓ (3), TCP/IP
Function	Data interface (read result output), service interface, FTP (image transmission)
Data transmission rate	10/100/1,000 Mbit/s, MAC address (device-specific), see type label
<b>CAN</b>	✓
Function	Data interface (read result output), Trigger interface
Data transmission rate	500 kbit/s
<b>Serial</b>	✓, RS-232, RS-422
Data transmission rate	1.2 kBaud ... 115.2 kBaud
<b>USB</b>	✓, USB 2.0
Function	Service interface (accessing the web server)
Data transmission rate	480 Mbit/s
<b>Digital inputs</b>	2 ("Sensor 1", "Sensor 2", insulated, encoder input, external trigger)
<b>Configurable digital inputs/outputs</b>	
X1	3 („DIO 4“, „DIO 5“, „DIO 6“)
<b>Reading pulse</b>	Digital inputs, CAN, auto pulse
<b>Optical indicators</b>	12 LEDs (10 x status displays, 2 x feedback spot)
<b>Operator interfaces</b>	Web server
<b>Configuration software</b>	SOPASair
<b>Memory card slot</b>	Micro SD memory card (not included with delivery) <sup>1)</sup>
<b>Parameter cloning</b>	Micro SD memory card Control software

<sup>1)</sup> Memory card is available as an optional accessory. To ensure that the memory card functions reliably, only use card types (industrial standard) approved by SICK. Other functions are available upon request.

<b>Data storage and retrieval</b>	Image and data storage via external FTP
<b>EncoderFrequency</b>	Max. 50 kHz
<b>External illumination control</b>	Via digital output (max. 24 V trigger)

<sup>1)</sup> Memory card is available as an optional accessory. To ensure that the memory card functions reliably, only use card types (industrial standard) approved by SICK. Other functions are available upon request.

### Ambient data

<b>Electromagnetic compatibility (EMC)</b>	
Interference resistance	IEC 61000-6-2:2016 / EN IEC 61000-6-2:2019
Interference emission	IEC 61000-6-4:2018 / EN IEC 61000-6-4:2019
<b>Vibration resistance</b>	EN 60068-2-6:2007, EN 60068-2-64:2019
<b>Shock resistance</b>	EN 60068-2-27:2008
<b>Ambient operating temperature</b>	0 °C ... +50 °C <sup>1)</sup>
<b>Storage temperature</b>	-20 °C ... +70 °C
<b>Permissible relative humidity</b>	≤ 90 %, Non-condensing
<b>Ambient light immunity</b>	2,000 lx, on code
<b>Contamination rating</b>	2 (EN 61010-1)
<b>Altitude (above sea level)</b>	< 5,000 m

<sup>1)</sup> If the ambient operating temperature will be ≥ 45 °C, ensure adequate heat dissipation when mounting the device.

### Classifications

<b>ECLASS 5.0</b>	27280103
<b>ECLASS 5.1.4</b>	27280103
<b>ECLASS 6.0</b>	27280103
<b>ECLASS 6.2</b>	27280103
<b>ECLASS 7.0</b>	27280103
<b>ECLASS 8.0</b>	27280103
<b>ECLASS 8.1</b>	27280103
<b>ECLASS 9.0</b>	27280103
<b>ECLASS 10.0</b>	27280103
<b>ECLASS 11.0</b>	27280103
<b>ECLASS 12.0</b>	27280103
<b>ETIM 5.0</b>	EC002550
<b>ETIM 6.0</b>	EC002550
<b>ETIM 7.0</b>	EC002999
<b>ETIM 8.0</b>	EC002999
<b>UNSPSC 16.0901</b>	43211701

Dimensional drawing (Dimensions in mm (inch))

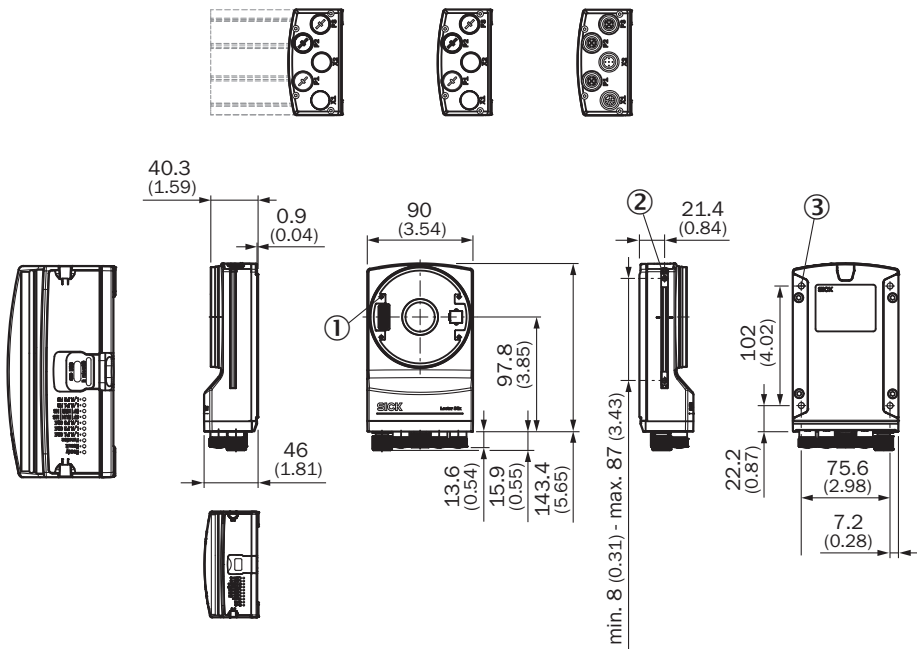

- ① 4 tapped blind holes, M2.5, 5.5 mm deep, for mounting the spacer
- ② 2 M5 sliding nuts; 5.5 mm deep; pivoting; as an alternative method of mounting the product
- ③ 4 tapped blind holes, M5, 5.5 mm deep for mounting the product

Field of view

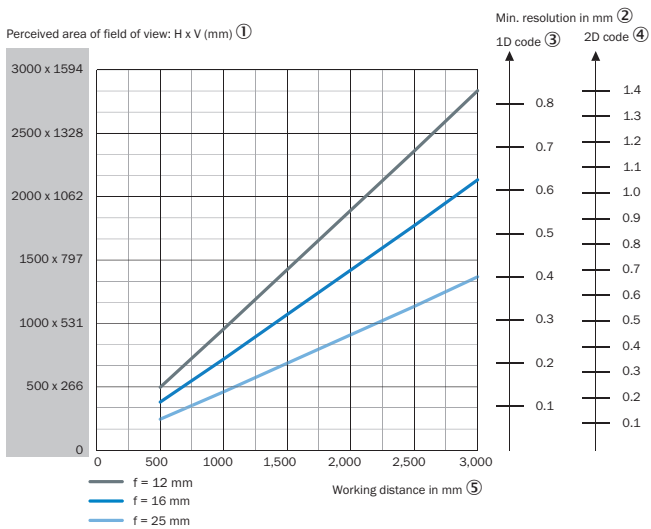

- ① Perceived field of view area: horizontal x vertical (mm)
- ② Minimum resolution in mm
- ③ 1D code
- ④ 2D code
- ⑤ Working distance in mm

### Selection Guide

V2D8509R, focal length: 12mm

#### FIELD OF VIEW

V2D8509R-xxxxxxx, focal length: 12 mm

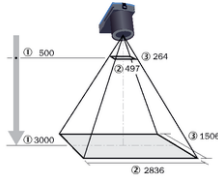

Figure 27: Field of view V2D8509R-xxxxxxx, focal length: 12 mm

- ① Working distance in mm
- ② Perceived field of view area: horizontal (mm)
- ③ Perceived field of view area: vertical (mm)

Table 11: Perceived field of view area

Working distance (mm)	Horizontal (mm)	Vertical (mm)
500	497	264
1000	965	513
1500	1433	761
2000	1900	1010
2500	2368	1258
3000	2836	1506

Table 12: Minimum resolution

Working distance (mm)	1D code (mm)	2D code (mm)
500	0.15	0.24
1000	0.28	0.48
1500	0.42	0.70
2000	0.56	0.92
2500	0.69	1.16
3000	0.83	1.38

FIELD OF VIEW

V2D8509R-xxxxxxx, focal length: 25 mm

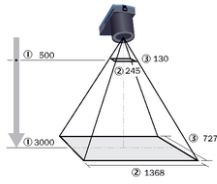

Figure 29: Field of view V2D8509R-xxxxxxx, focal length: 25 mm

- ① Working distance in mm
- ② Perceived field of view area: horizontal (mm)
- ③ Perceived field of view area: vertical (mm)

Table 15: Perceived field of view area

Working distance (mm)	Horizontal (mm)	Vertical (mm)
500	245	130
1000	470	250
1500	694	369
2000	919	488
2500	1143	607
3000	1368	727

Table 16: Minimum resolution

Working distance (mm)	1D code (mm)	2D code (mm)
500	0.07	0.12
1000	0.14	0.22
1500	0.20	0.34
2000	0.27	0.44
2500	0.33	0.56
3000	0.40	0.66

V2D8509R, focal length: 16mm

### FIELD OF VIEW

V2D8509R-xxxxxxx, focal length: 16 mm

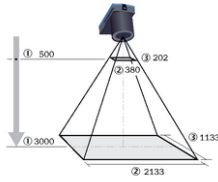

Figure 28: Field of view V2D8509R-xxxxxxx, focal length: 16 mm

- ① Working distance in mm
- ② Perceived field of view area: horizontal (mm)
- ③ Perceived field of view area: vertical (mm)

Table 13: Perceived field of view area

Working distance (mm)	Horizontal (mm)	Vertical (mm)
500	380	202
1000	731	388
1500	1081	574
2000	1432	761
2500	1783	947
3000	2133	1133

Table 14: Minimum resolution

Working distance (mm)	1D code (mm)	2D code (mm)
500	0.11	0.18
1000	0.21	0.36
1500	0.32	0.52
2000	0.42	0.70
2500	0.52	0.88
3000	0.62	1.04

## Recommended services

Additional services → [www.sick.com/Lector85x](http://www.sick.com/Lector85x)

	Type	Part no.
Performance check		
<ul style="list-style-type: none"> <li>• <b>Product area:</b> Image-based code readers</li> <li>• <b>Range of services:</b> Inspection of defined functions, e.g., reading performance</li> <li>• <b>Duration:</b> Additional work will be invoiced separately</li> </ul>	Performance check Lector	1608207
Maintenance		
<ul style="list-style-type: none"> <li>• <b>Product area:</b> Image-based code readers</li> <li>• <b>Range of services:</b> Inspection, analysis and restoring of defined functions, Inspection and adaptation of previously defined functions of possible Lector6xx illumination, code configuration, trigger and digital inputs, interfaces and digital outputs as well as data processing</li> <li>• <b>Duration:</b> Additional work will be invoiced separately</li> </ul>	Maintenance Lector	1611421



	Type	Part no.
Commissioning		
<ul style="list-style-type: none"><li>• <b>Product area:</b> Image-based code readers</li><li>• <b>Range of services:</b> Inspection of connection, fine adjustment, optimization of parameters of SICK product as well as tests, Set-up of previously defined functions of possible illumination, code configuration, trigger and digital inputs, interfaces and digital outputs as well as data processing</li><li>• <b>Duration:</b> Additional work will be invoiced separately</li></ul>	Commissioning Lector	1608206

## SICK AT A GLANCE

SICK is one of the leading manufacturers of intelligent sensors and sensor solutions for industrial applications. A unique range of products and services creates the perfect basis for controlling processes securely and efficiently, protecting individuals from accidents and preventing damage to the environment.

We have extensive experience in a wide range of industries and understand their processes and requirements. With intelligent sensors, we can deliver exactly what our customers need. In application centers in Europe, Asia and North America, system solutions are tested and optimized in accordance with customer specifications. All this makes us a reliable supplier and development partner.

Comprehensive services complete our offering: SICK LifeTime Services provide support throughout the machine life cycle and ensure safety and productivity.

For us, that is “Sensor Intelligence.”

## WORLDWIDE PRESENCE:

Contacts and other locations –[www.sick.com](http://www.sick.com)