



V3S102-1AAAAAA

Visionary-S

3D MACHINE VISION

SICK
Sensor Intelligence.



Illustration may differ



Ordering information

Type	Part no.
V3S102-1AAAAAA	1090184

Other models and accessories → www.sick.com/Visionary-S

Detailed technical data

Features

Technology	3D snapshot stereoscopy
Pre-calibrated	✓
Product category	Configurable, Streaming, pre-calibrated
Integrated application	2D and 3D data flow with the option of filtering data in the device
Working distance	0.5 m ... 6.5 m 0.5 m ... 65 m ¹⁾
Example field of view	1.6 m x 1.3 m ²⁾
Detection angle	60° x 50°
Angular resolution	0.094° x 0.098°
Illumination	Integrated
Illumination color	Infrared, laser, invisible, 808 nm
Laser class	1 (IEC 60825-1:2014, EN 60825-1:2014+A11:2021) ³⁾
Task	Detecting - Standard objects Measuring - Dimension, contour and volume Identifying - Classifying Localizing, navigating and guiding - Guiding Determining position - 3D position determination

¹⁾ The "remote scanning range" can be selected with the distance mode in the user interface.

²⁾ See "Detection zone and field of view" table for individual values.

³⁾ Complies with 21 CFR 1040.10 and 1040.11 except for deviations pursuant to IEC 60825-1 Ed. 3. according to Laser Notice No. 56 dated May 08, 2019.

Mechanics/electronics

Connection type	Power/I/O: M12 17-pin, A-coded Gigabit Ethernet: M12, 8-pin, X-coded
Supply voltage	24 V DC, ± 15 %
Power consumption	19 W, without digital I/Os
Peak current	3 A
Enclosure rating	IP67

¹⁾ With cooling fins.

Protection class	III
Housing color	Blue, black
Weight	2.2 kg, with cooling fins
Dimensions (L x W x H)	162 mm x 116 mm x 104 mm ¹⁾
Mounting	Any

¹⁾ With cooling fins.

Performance

Pixel count	640 px x 512 px
Scan/frame rate	30 fps, Up to 9,850,000 3D data points/s ¹⁾
Repeatability	≤ 0.25 mm, at 0.5 m scanning range
Switch-on delay	< 20 s (typical)
Response time	< 66 ms

¹⁾ 0.03 s per 3D image.

Interfaces

Ethernet	✓
Function	Complete data stream combining distance and RGB values in one snapshot plus device control
Data transmission rate	700 Mbit/s, communication interface Gigabit Ethernet (TCP/IP)
Configuration software	SOPAS ET, Telegram interface
Digital input	2
Digital output	4
Optical indicators	2 status LEDs

Ambient data

Electromagnetic compatibility (EMC)	EN 61000-6-2:2005-08, EN 61000-6-3:2007-01
Vibration resistance	EN 60068-2-6, EN 60068-2-64
Shock resistance	EN 60068-2-27
Ambient operating temperature	0 °C ... +50 °C, with cooling fins
Storage temperature	-20 °C ... +70 °C
Ambient light immunity	< 40 klx, Sunlight

Classifications

ECLASS 5.0	27310205
ECLASS 5.1.4	27310205
ECLASS 6.0	27310205
ECLASS 6.2	27310205
ECLASS 7.0	27310205
ECLASS 8.0	27310205
ECLASS 8.1	27310205
ECLASS 9.0	27310205
ECLASS 10.0	27310205
ECLASS 11.0	27310205
ECLASS 12.0	27310205

ETIM 5.0	EC001820
ETIM 6.0	EC001820
ETIM 7.0	EC001820
ETIM 8.0	EC001820
UNSPSC 16.0901	43211731

Dimensional drawing (Dimensions in mm (inch))

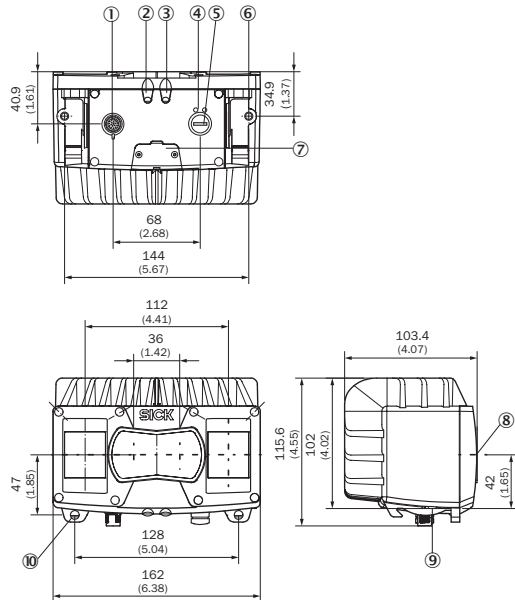

- ① Power/I/O: M12 17-pin, A-coded
- ② Device display
- ③ Application display
- ④ Ethernet status displays
- ⑤ Gigabit Ethernet: M12, 8-pin, X-coded
- ⑥ M6 threaded hole, 7 mm deep (2x), for mounting
- ⑦ Service interface
- ⑧ Optical axis
- ⑨ Bracket interface
- ⑩ Bracket attachment

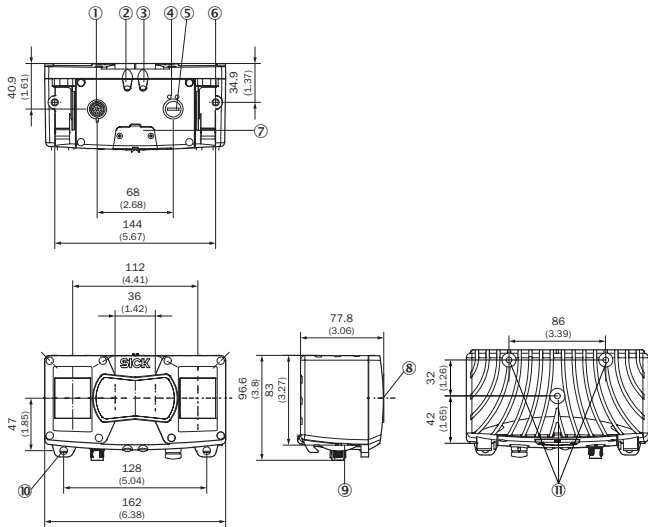

- ① Power/I/O: M12 17-pin, A-coded
- ② Device display
- ③ Application display
- ④ Ethernet status displays
- ⑤ Gigabit Ethernet: M12, 8-pin, X-coded
- ⑥ M6 threaded hole, 7 mm deep (2x), for mounting
- ⑦ Service interface
- ⑧ Optical axis
- ⑨ Bracket interface
- ⑩ Bracket attachment
- ⑪ M6 threaded hole, 10 mm deep (3x), for mounting

Field of view

Detection volume and field of view

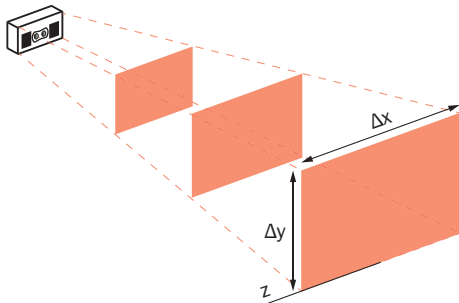

Absolute working distance (z)	Measuring range ($\Delta x \times \Delta y$)		Measurement accuracy Δz (average value)	Repeatability σz (average value)
0.50 m	~ 45 cm x 45 cm	~ 1 mm x 1 mm	< 1.5 mm	± 0.25 mm
1.00 m	~ 100 cm x 90 cm	~ 2 mm x 2 mm	< 2.5 mm	± 0.60 mm
1.50 m	~ 160 cm x 130 cm	~ 3 mm x 3 mm	< 3.0 mm	± 1.50 mm
2.00 m	~ 220 cm x 180 cm	~ 4 mm x 4 mm	< 4.5 mm	± 2.00 mm
2.50 m	~ 280 cm x 230 cm	~ 5 mm x 5 mm	< 6.0 mm	± 4.00 mm

Connection type

Connection: Power/I/O

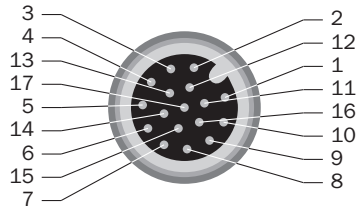

Power/I/O: M12 17-pin, A-coded

- ① GND – reference mass
- ② Supply voltage
- ③ CAN L – reserved, not implemented. Do not connect to VCC!
- ④ CAN H – reserved, not implemented. Do not connect to VCC!
- ⑤ TD+ (RS-422/485) Host – reserved, not implemented. Do not connect to VCC!
- ⑥ TD- (RS-422/485) Host, TxD (RS-232), Host – reserved, not implemented. Do not connect to VCC!
- ⑦ TxD (RS-232), Aux – service only
- ⑧ RxD (RS-232), Aux – service only
- ⑨ SENS GND – GND for electrically decoupled inputs
- ⑩ SENS IN1 – switch input, electrically decoupled
- ⑪ RD+ (RS-422) Host – reserved, not implemented. Do not connect to VCC!
- ⑫ RD- (RS-422/485) Host, RxD (RS-232), Host – reserved, not implemented. Do not connect to VCC!
- ⑬ INOUT 1 - Programmable digital I/O
- ⑭ INOUT 2 - Programmable digital I/O
- ⑮ SENS IN2 – switch input, electrically decoupled
- ⑯ INOUT 3 - Programmable digital I/O
- ⑰ INOUT 4 - Programmable digital I/O

Gigabit Ethernet

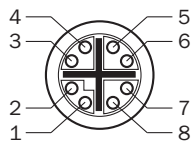



Gigabit Ethernet: M12, 8-pin, X-coded

- ① TRD0_P
- ② TRD0_N
- ③ TRD1_P
- ④ TRD1_N
- ⑤ TRD3_P
- ⑥ TRD3_N
- ⑦ TRD2_P
- ⑧ TRD2_N

Recommended accessories

Other models and accessories → www.sick.com/Visionary-S

	Brief description	Type	Part no.
Terminal and alignment brackets			
	1 piece, Bracket including clamps and screws, metal, Bracket including clamps and screws	Mounting set (2-part) incl. clamps and screws	2077710
	1 piece, 2x clamps and 2x screws, metal, 2 clamps and 2 screws	2x clamps, 2x screws	2077709

Recommended services

Additional services → www.sick.com/Visionary-S

	Type	Part no.
Extended warranty		
<ul style="list-style-type: none">• Product area: Machine vision, LiDAR sensors, safety camera sensors, Safety laser scanners, Safety radar sensors, Radar sensors, Fixed mount barcode scanners, Image-based code readers, RFID, Mobile handheld scanners• Range of services: The services correspond to the scope of the statutory warranty (SICK General Terms of Delivery)• Duration: Five-year warranty from delivery date.	Extended warranty for a total of five years from delivery date	1680671

SICK AT A GLANCE

SICK is one of the leading manufacturers of intelligent sensors and sensor solutions for industrial applications. A unique range of products and services creates the perfect basis for controlling processes securely and efficiently, protecting individuals from accidents and preventing damage to the environment.

We have extensive experience in a wide range of industries and understand their processes and requirements. With intelligent sensors, we can deliver exactly what our customers need. In application centers in Europe, Asia and North America, system solutions are tested and optimized in accordance with customer specifications. All this makes us a reliable supplier and development partner.

Comprehensive services complete our offering: SICK LifeTime Services provide support throughout the machine life cycle and ensure safety and productivity.

For us, that is “Sensor Intelligence.”

WORLDWIDE PRESENCE:

Contacts and other locations –www.sick.com