



WTT12S-C2569

WTT12 PowerProx

TIME-OF-FLIGHT SENSORS

SICK
Sensor Intelligence.



Illustration may differ



Ordering information

Type	Part no.
WTT12S-C2569	1136898

Other models and accessories → www.sick.com/WTT12_PowerProx

Detailed technical data

Features

Functional principle	Photoelectric proximity sensor
Functional principle detail	Absence of reference object or reference surface
Housing design (light emission)	Rectangular
Safety-related detection zone	150 mm ... 2,000 mm, Target with 6% remission or higher. The laser beam hits the target surface at an angle of incidence of 90°, the light spot is covered fully by the target. Distance front of sensor to reference surface: 150 mm ... 2,000 mm, distance reference surface to background, e.g., step/opening: > 85 mm ¹⁾
Type of light	Visible red light
Light source	Laser ²⁾
Light spot size (distance)	Ø 15 mm (within the sensing range)
Maximum pulse power	< 250 mW
Wave length	658 nm
Pulse duration	0.004 µs
Laser class	1 (IEC 60825-1 / CDRH 21 CFR 1040.10 & 1040.11)
Adjustment	Single teach-in button (1 x)
Safety-related parameters	
Safety integrity level	SIL 1 (IEC 61508)
Performance class SRS/SRSS	C (IEC TS 62998-1)
Performance level	PL c (ISO 13849-1)
Category	Category 2 (ISO 13849-1)
MTTF _D	138 years (ISO 13849-1)
PFH _D (mean probability of a dangerous failure per hour)	3,3 x 10 ⁻⁷

¹⁾ Customer may vary incident angle and target remission but needs to ensure effective reserve is within corridor as stated (the lower incident angle, the farther the distance the lower the reserve).

²⁾ Average service life: 100,000 h at T_U = +25 °C.

DC _{avg}	60 %
T _M (mission time)	20 years (ISO 13849-1, rate of use: 60 %)
Maximum demand rate	36 /h
Test rate (external test)	At least 100 times the average expected demand rate (ISO 13849-1)

1) Customer may vary incident angle and target remission but needs to ensure effective reserve is within corridor as stated (the lower incident angle, the farther the distance the lower the reserve).

2) Average service life: 100,000 h at T_U = +25 °C.

Electronics

Supply voltage U_B	10 V DC ... 30 V DC ¹⁾
Ripple	< 5 V _{pp} ²⁾
Current consumption	≤ 25 mA ³⁾
Switching output	Push-pull: PNP/NPN
Switching output (voltage)	LOW ≤ 3 V HIGH ≥ U _v - 4 V
Output function	Modulated 10 Hz ± 2% square wave, 50% duty cycle
Number of switching outputs	1
Switching mode	Light switching
Response time	
Digital output to object	5 ms
Digital output to test input	10 ms
Test input behavior	High: Offset switchover from +35 mm to -35 mm
Test input voltage	LOW ≤ 3 V HIGH ≥ U _v - 4 V
Number of digital inputs	1
Input function	Diagnostics
Circuit protection	A ⁴⁾ B ⁵⁾ C ⁶⁾
Protection class	III
Enclosure rating	IP67
Warm-up time	< 15 min ⁷⁾
Initialization time	< 300 ms

1) As of T_a = 45 °C, a max.load current I_{max} = 50 mA is permitted.

2) May not fall below or exceed U_v tolerances.

3) Without load. At V_S = 24 V.

4) A = V_S connections reverse-polarity protected.

5) B = inputs and output reverse-polarity protected.

6) C = interference suppression.

7) Below T_U = -10 °C a warm-up time is necessary.

Mechanics

Dimensions (W x H x D)	20 mm x 49.6 mm x 44.2 mm
Housing material	Plastic, VISTAL®
Optics material	Plastic, PMMA

Weight	48 g
Connection type	Male connector M12, 5-pin

Ambient data

Ambient operating temperature	-35 °C ... +50 °C ¹⁾
Ambient temperature, storage	-40 °C ... +70 °C
Typ. Ambient light immunity	Artificial light: 50 klx Sunlight: 50 klx
Shock resistance	30 g (3 positive and 3 negative shocks along X, Y, Z axes, 18 total shocks (EN60068-2-27)) 11 ms 25 g (1,000 positive and 1,000 negative shocks along X, Y, Z axes, 6000 shocks in total (EN60068-2-27)) 6 ms
Vibration resistance	20 Hz ... 1,000 Hz (1 g, for X, Y, Z axes, 1 octave/min (EN60068-2-6)) 20 Hz ... 2,000 Hz (10 g, RMS/axis (EN 60068-2-64))

¹⁾ As of $T_a = 45\text{ °C}$, a max.load current $I_{max} = 50\text{ mA}$ is permitted.

Classifications

ECLASS 5.0	27270904
ECLASS 5.1.4	27270904
ECLASS 6.0	27270904
ECLASS 6.2	27270904
ECLASS 7.0	27270904
ECLASS 8.0	27270904
ECLASS 8.1	27270904
ECLASS 9.0	27270904
ECLASS 10.0	27270904
ECLASS 11.0	27270904
ECLASS 12.0	27270903
ETIM 5.0	EC002719
ETIM 6.0	EC002719
ETIM 7.0	EC002719
ETIM 8.0	EC002719
UNSPSC 16.0901	39121528

Dimensional drawing (Dimensions in mm (inch))

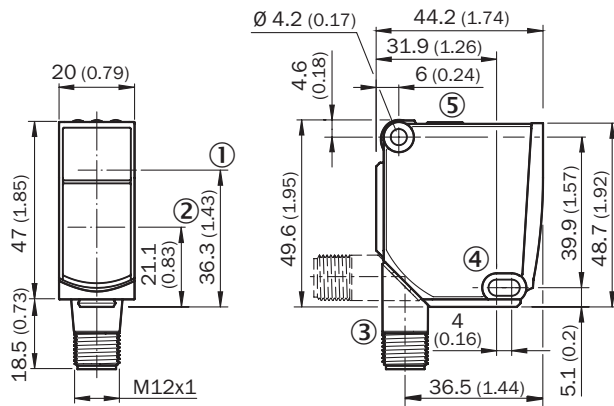

- ① Center of optical axis, sender
- ② Center of optical axis, receiver
- ③ Connection
- ④ Mounting hole, Ø 4.2 mm
- ⑤ Display and adjustment elements

Adjustments

Display and adjustment elements

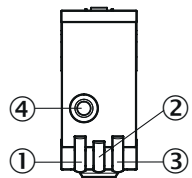

- ① LED yellow 1
- ② LED green
- ③ LED yellow 2
- ④ Single teach-in button

Connection diagram

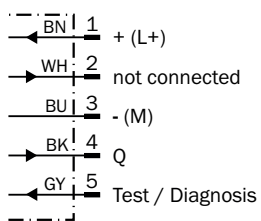

Light spot size

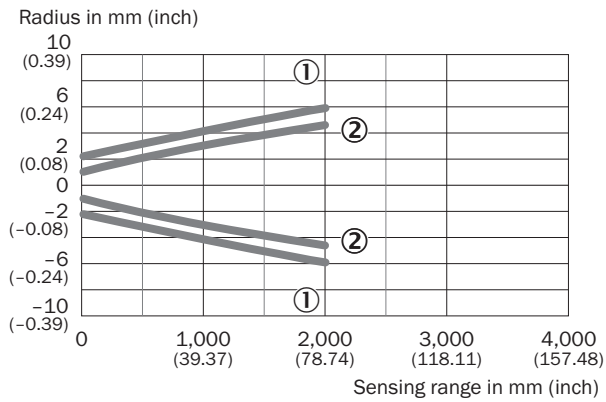

- ① Light spot horizontal
- ② Light spot vertical

Functional principle

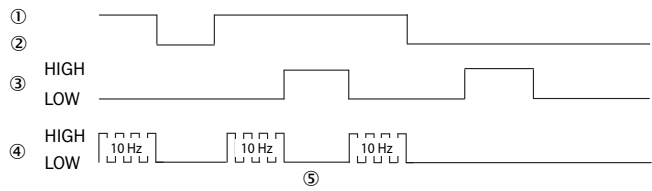

- ① Reference
- ② Level
- ③ Test input
- ④ Output
- ⑤ Test for reference, step is simulated

SICK AT A GLANCE

SICK is one of the leading manufacturers of intelligent sensors and sensor solutions for industrial applications. A unique range of products and services creates the perfect basis for controlling processes securely and efficiently, protecting individuals from accidents and preventing damage to the environment.

We have extensive experience in a wide range of industries and understand their processes and requirements. With intelligent sensors, we can deliver exactly what our customers need. In application centers in Europe, Asia and North America, system solutions are tested and optimized in accordance with customer specifications. All this makes us a reliable supplier and development partner.

Comprehensive services complete our offering: SICK LifeTime Services provide support throughout the machine life cycle and ensure safety and productivity.

For us, that is “Sensor Intelligence.”

WORLDWIDE PRESENCE:

Contacts and other locations –www.sick.com