



# i11-S213

i11S

**ELECTRO-MECHANICAL SAFETY SWITCHES**

**SICK**  
Sensor Intelligence.



actuator not supplied with delivery



## Ordering information

Type	Part no.
i11-S213	6022583

The actuator has to be ordered separately. See "Accessories" for further details.

Other models and accessories → [www.sick.com/i11S](http://www.sick.com/i11S)

## Detailed technical data

### Features

<b>Positive action N/C contacts</b>	2
<b>N/O contacts</b>	1
<b>Retaining force</b>	≤ 10 N
<b>Actuation frequency</b>	≤ 7,000 /h
<b>Actuation directions</b>	5
<b>Approach speed</b>	≤ 20 m/min

### Safety-related parameters

<b>B<sub>10d</sub> parameter</b>	4 x 10 <sup>6</sup> switching cycles (with small load)
<b>Type</b>	Type 2 (EN ISO 14119)
<b>Actuator coding level</b>	Low coding level (EN ISO 14119)
<b>Safe state in the event of a fault</b>	The switch has no internal fault detection and is unable to assume a safe state in the event of a fault. Fault detection is performed by the connected safety-related logic unit.

### Functions

<b>Safe series connections</b>	None, only individual wiring (with diagnostics)
--------------------------------	---

### Interfaces

<b>Connection type</b>	Cable gland, 3 x M16
Conductor cross section	≤ 1.5 mm <sup>2</sup>

### Electrical data

<b>Switching principle</b>	Slow action switching element
<b>Usage category</b>	AC-15/DC-13
<b>Rated operating current (voltage)</b>	4 A (230 V AC) 4 A (24 V DC)
<b>Rated insulation voltage U<sub>i</sub></b>	250 V
<b>Rated impulse withstand voltage U<sub>imp</sub></b>	2,500 V
<b>Short-circuit protection</b>	4 A gG

<b>Switching voltage</b>	≥ 12 V DC
<b>Switching current (switching voltage)</b>	1 mA (24 V DC)

## Mechanical data

<b>Weight</b>	+ 0.1 kg
<b>Housing material</b>	Glass-fiber reinforced thermoplastic
<b>Mechanical life</b>	1 x 10 <sup>6</sup> switching cycles

## Ambient data

<b>Enclosure rating</b>	IP67
<b>Ambient operating temperature</b>	-20 °C ... +80 °C
<b>Storage temperature</b>	-20 °C ... +80 °C

## Classifications

<b>ECLASS 5.0</b>	27272602
<b>ECLASS 5.1.4</b>	27272602
<b>ECLASS 6.0</b>	27272602
<b>ECLASS 6.2</b>	27272602
<b>ECLASS 7.0</b>	27272602
<b>ECLASS 8.0</b>	27272602
<b>ECLASS 8.1</b>	27272602
<b>ECLASS 9.0</b>	27272602
<b>ECLASS 10.0</b>	27272602
<b>ECLASS 11.0</b>	27272602
<b>ECLASS 12.0</b>	27272602
<b>ETIM 5.0</b>	EC002592
<b>ETIM 6.0</b>	EC002592
<b>ETIM 7.0</b>	EC002592
<b>ETIM 8.0</b>	EC002592
<b>UNSPSC 16.0901</b>	39122205

Dimensional drawing (Dimensions in mm (inch))

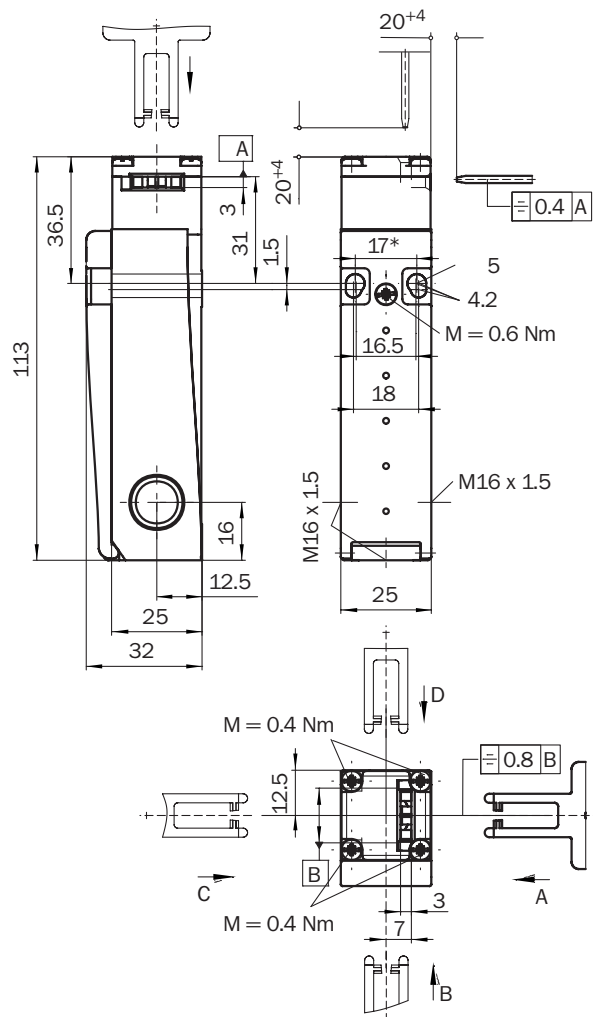

Switching elements

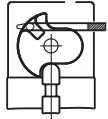
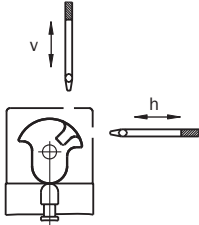
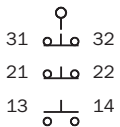
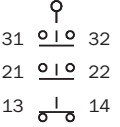
	Actuator inserted	Actuator removed
		
Switching element 21		

**Switching element 21:**  
2 positive action N/C contacts + 1 N/O contact

## SICK AT A GLANCE

SICK is one of the leading manufacturers of intelligent sensors and sensor solutions for industrial applications. A unique range of products and services creates the perfect basis for controlling processes securely and efficiently, protecting individuals from accidents and preventing damage to the environment.

We have extensive experience in a wide range of industries and understand their processes and requirements. With intelligent sensors, we can deliver exactly what our customers need. In application centers in Europe, Asia and North America, system solutions are tested and optimized in accordance with customer specifications. All this makes us a reliable supplier and development partner.

Comprehensive services complete our offering: SICK LifeTime Services provide support throughout the machine life cycle and ensure safety and productivity.

For us, that is “Sensor Intelligence.”

## WORLDWIDE PRESENCE:

Contacts and other locations –[www.sick.com](http://www.sick.com)